



Pump • Fire Fighting Units • Booster Set

C

SUBMERSIBLE SEWAGE PUMPS

Handled Liquids

Domestic and industrial waste water, raw sewage, liquids with fibrous and solid substances.

Technical Data

Discharge Flange _____ DN 50.....DN 300 mm

Capacity _____ up to 1600 m³/h

Head _____ up to 95 m

Speed _____ up to 2900 rpm

Operating Temperature _____ up to +40 °C

Casing Pressure (Pmax) _____ 10 bar

Design Features

•Vertical, wide volute casing, single stage, end suction submersible type centrifugal pump with enclosed, semi-open or vortex types impeller.

•20 basic sizes covering wide range of operational area.

•Electric motor isolation class is IP 68.

Pump Designation

Pump Type _____

Discharge Nozzle (DN-mm) _____

Impeller Nominal Diameter (mm) _____

Impeller Type _____

C 100 - 240 B



•Discharge flanges conform to EN 1092-2 / PN 10. (EN 1092-1 / PN 10 for steel or stainless steel casing)

•All impellers are balanced dynamically or statically according to ISO 1940 class 6.3.

•Axial thrust is balanced by impeller back ribs.

•In case of request motor cooling jacket is also applicable (for pumps bigger than 12 HP)

•Bearings of C type pumps are "life time grease lubricated" ball bearings.

Shaft Sealing

•For pumps bigger than 12 HP, always double mechanical seal is applied while for pumps up to 12 HP, single mechanical seal is applied as standard.

•In case of request, double mechanical seal can also be applied for pumps up to 12HP.

Field Chart

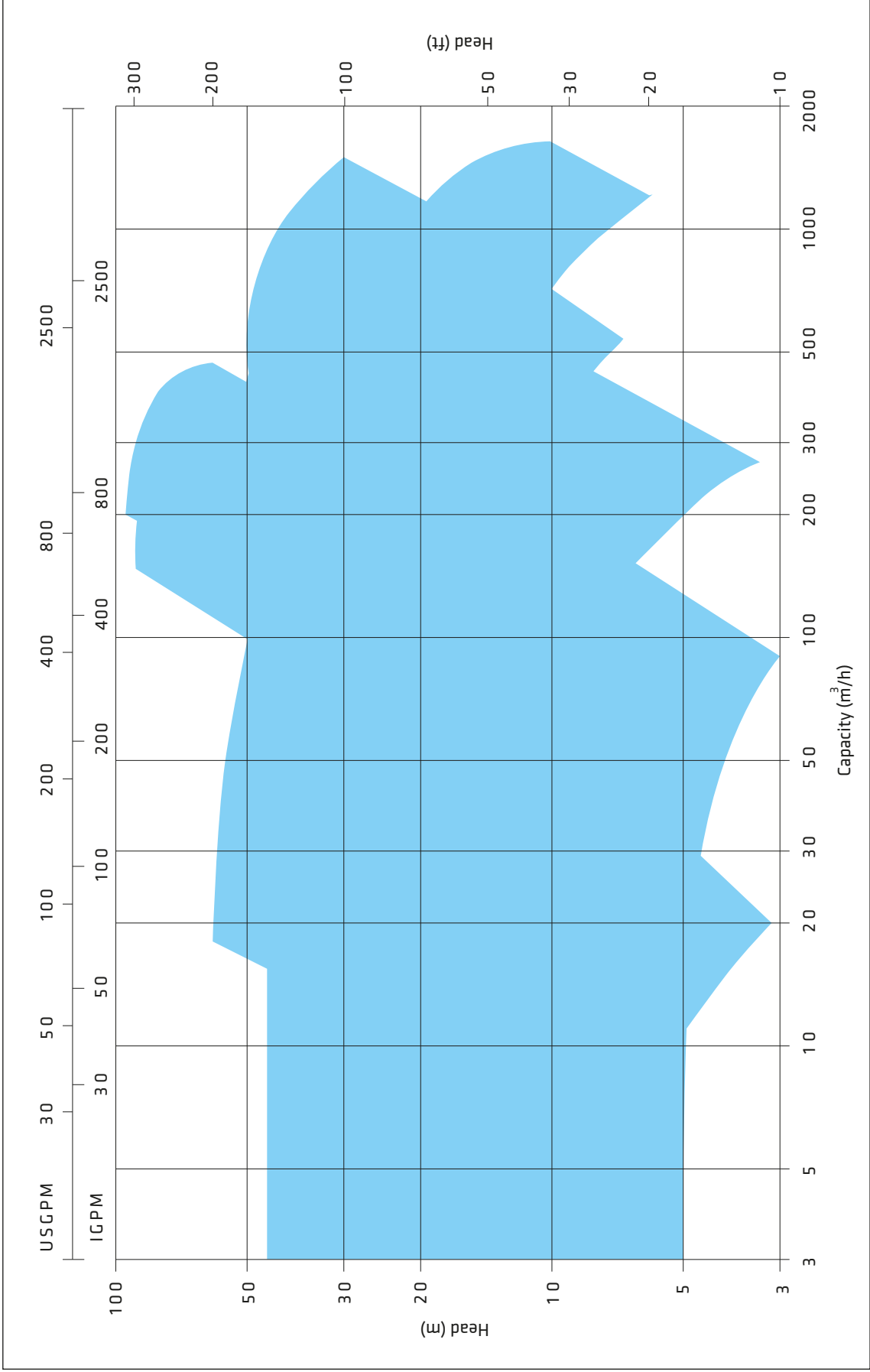

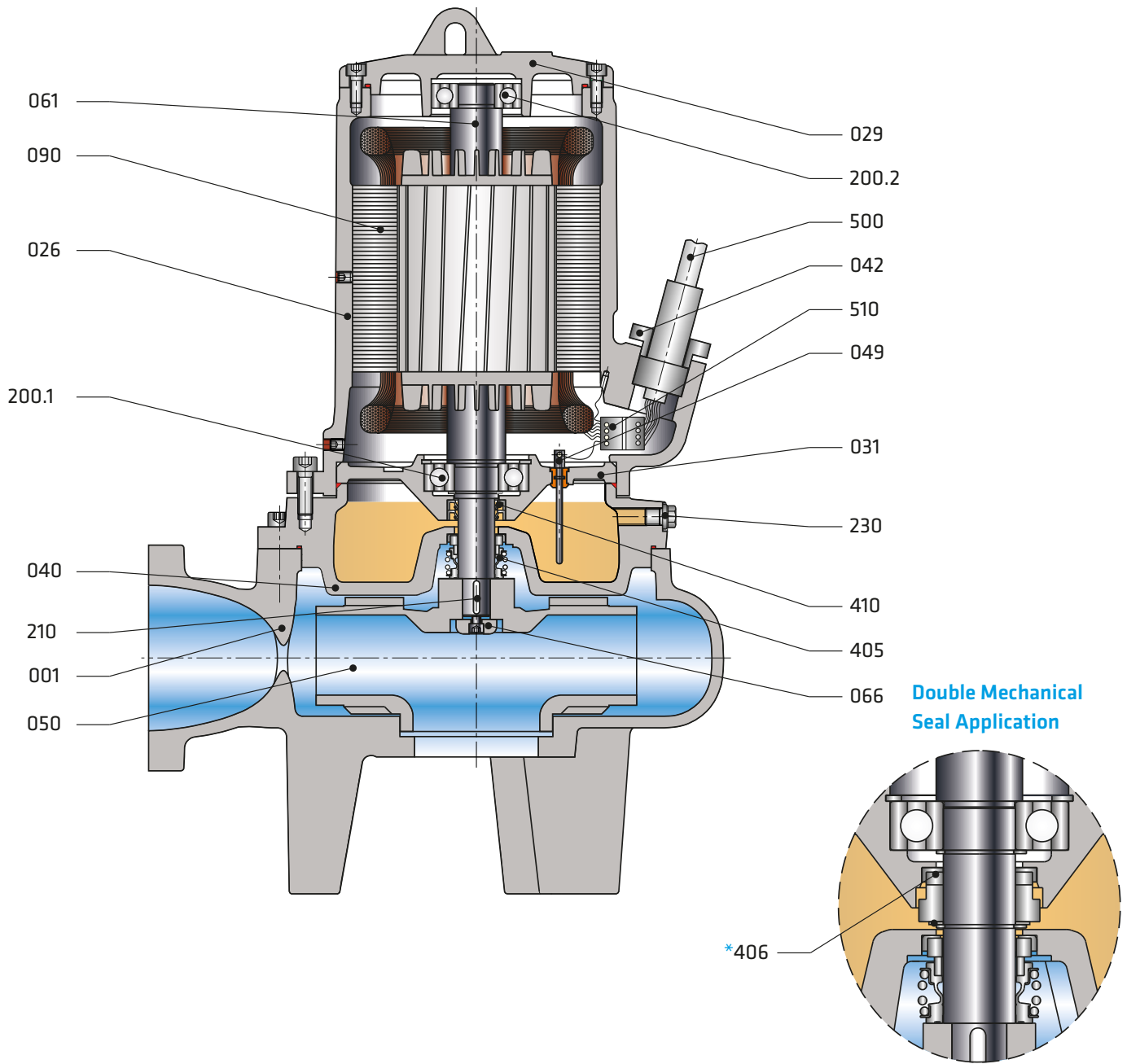

Part List

001	Volute Casing	090	Stator
026	Motor Casing	200.1	Bottom Bearing
029	Top Cover	200.2	Top Bearing
031	Bearing Housing	210	Impeller Key
040	Oil Chamber	230	Oil Plug
042	Gland	405	Mechanical Seal
049	Water Leakage Electrode	*406	Mechanical Seal
050	Impeller	410	Oil Seal
061	Rotor Shaft	500	Energy and Control Cable with Plug
066	Impeller Nut	510	Socket

* Optional

Sectional Drawing (bigger than 12 HP)

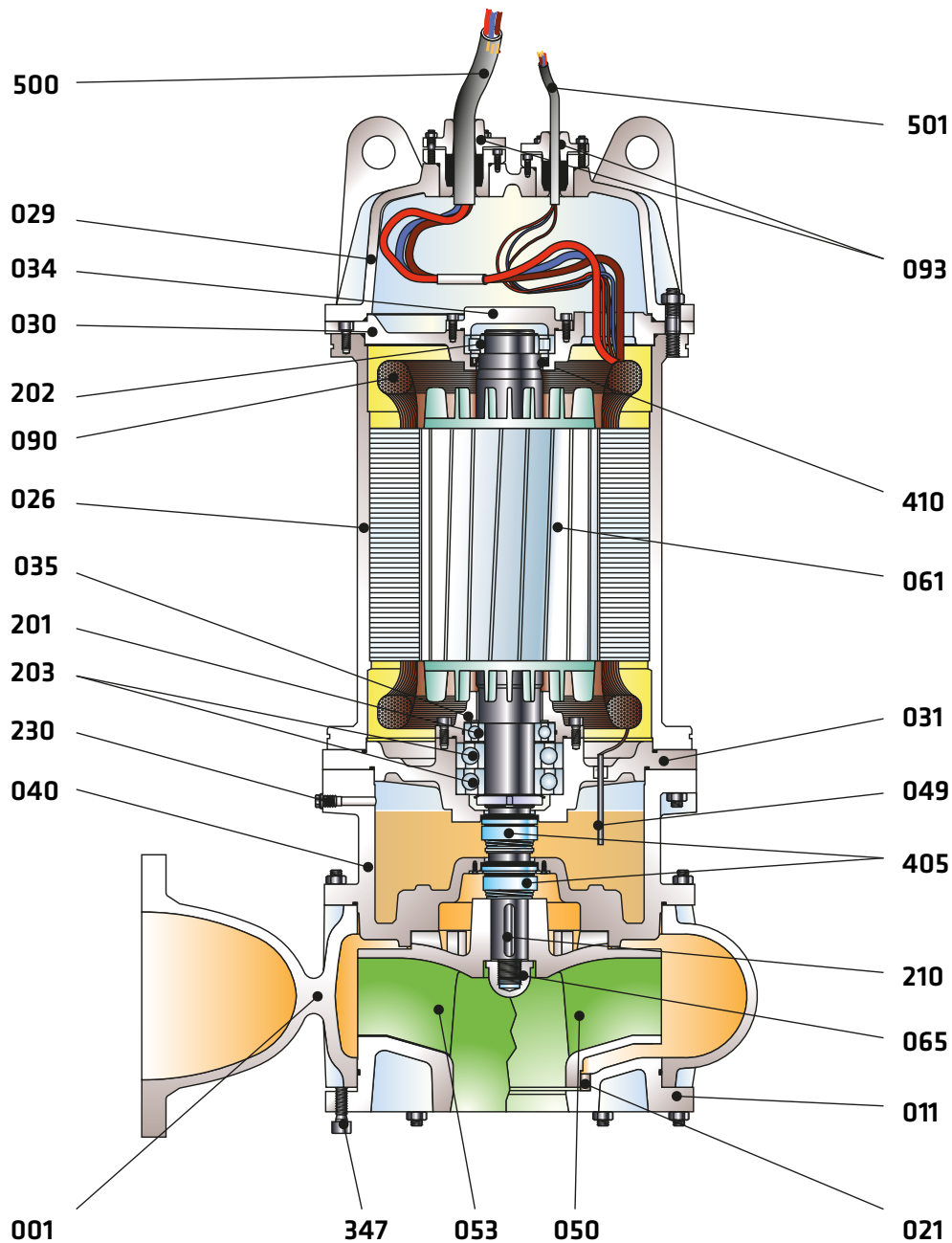

Part List

001	Volute Casing	040	Oil Chamber	202	Bottom Bearing
011	Bottom Cover	049	Water Leakage Electrode	203	Angular Contact Ball Bearing
021	Wear Ring	050	Closed Impeller	210	Impeller Key
026	Motor Casing	053	Semi-open Impeller	230	Oil Plug
029	Top Cover	061	Rotor Shaft	347	Adjustment Bolt
030	Top Bearing Housing	065	Impeller Nut	405	Mechanical Seal
031	Bottom Bearing Housing	090	Stator	410	Oil Seal
034	Top Bearing Cover	093	Gasket Compress Cover	500	Energy Cable
035	Bottom Bearing Cover	201	Bottom Bearing	501	Control Cable

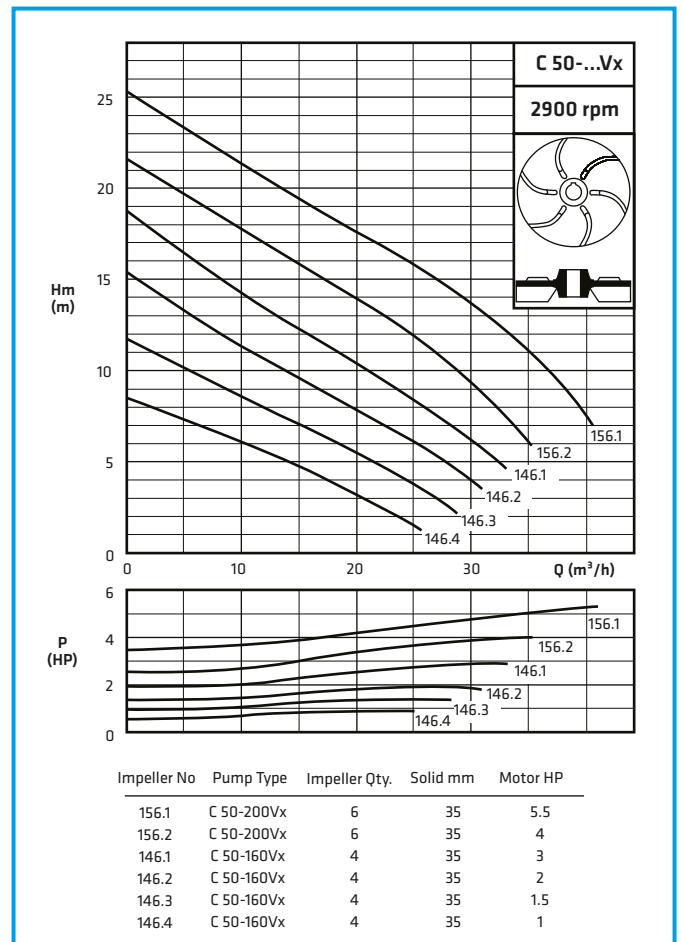
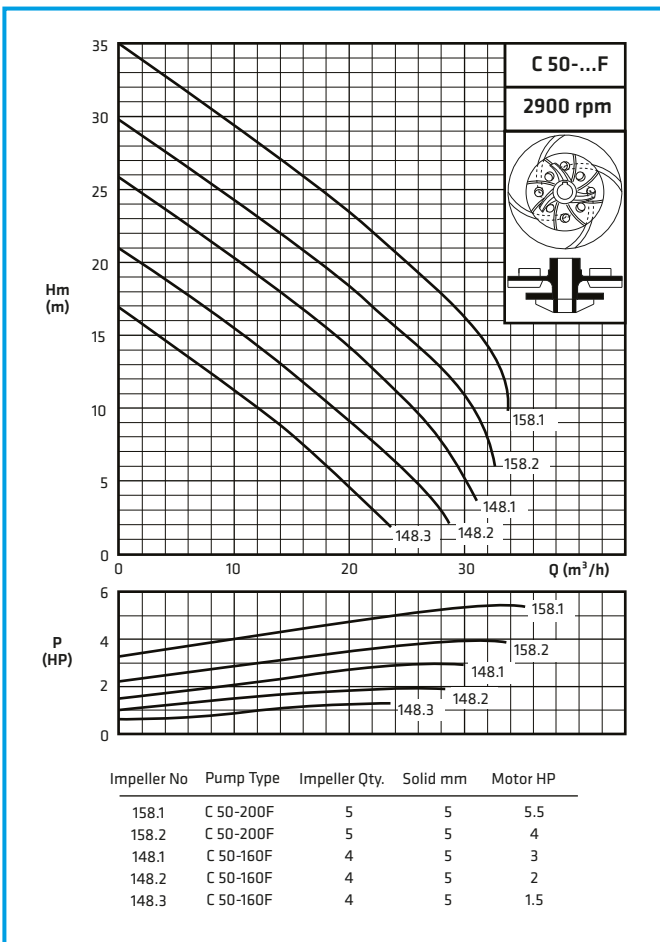
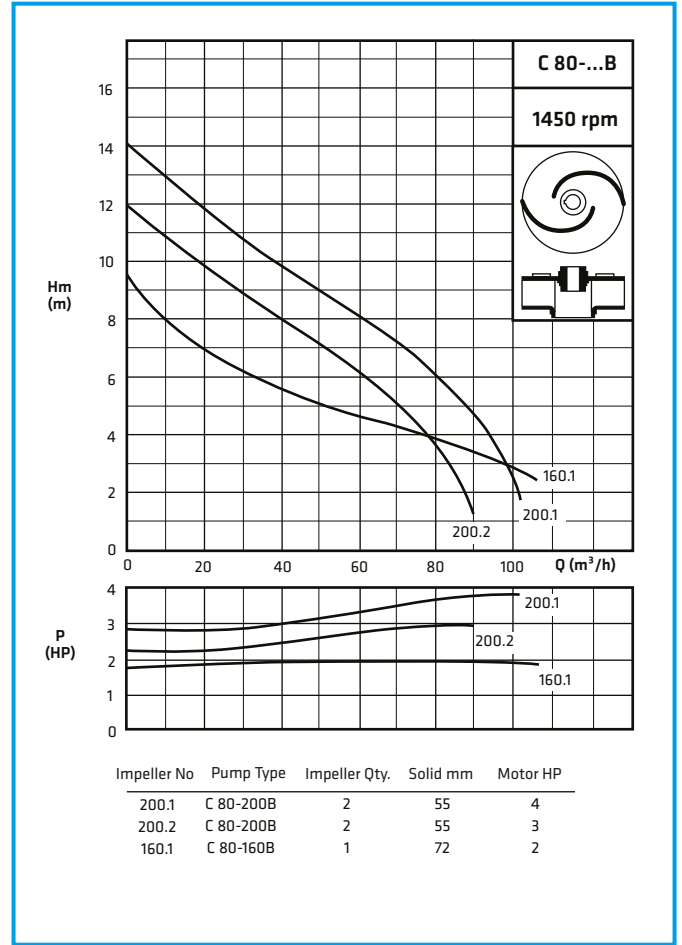
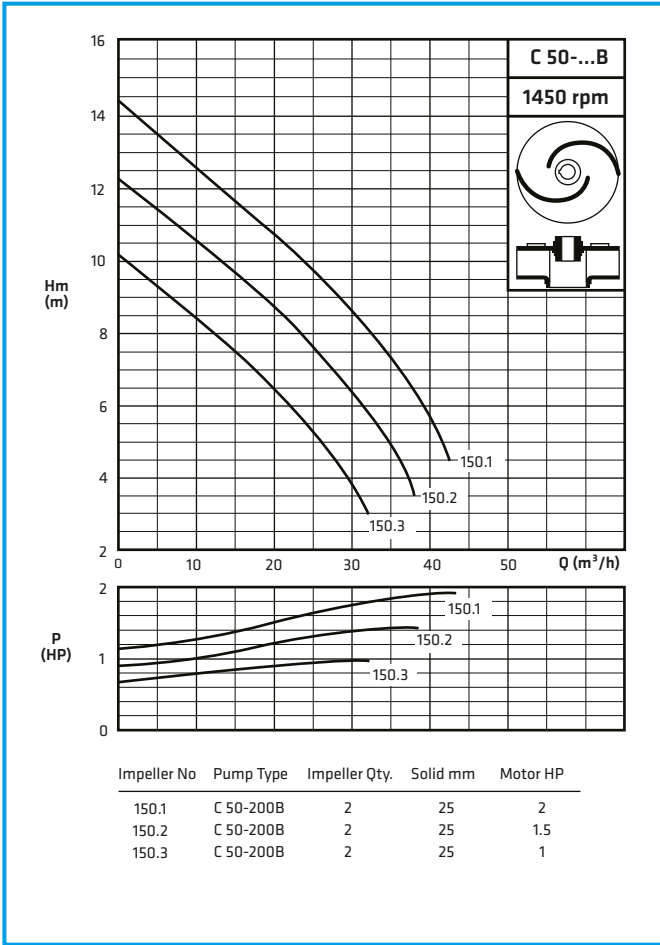

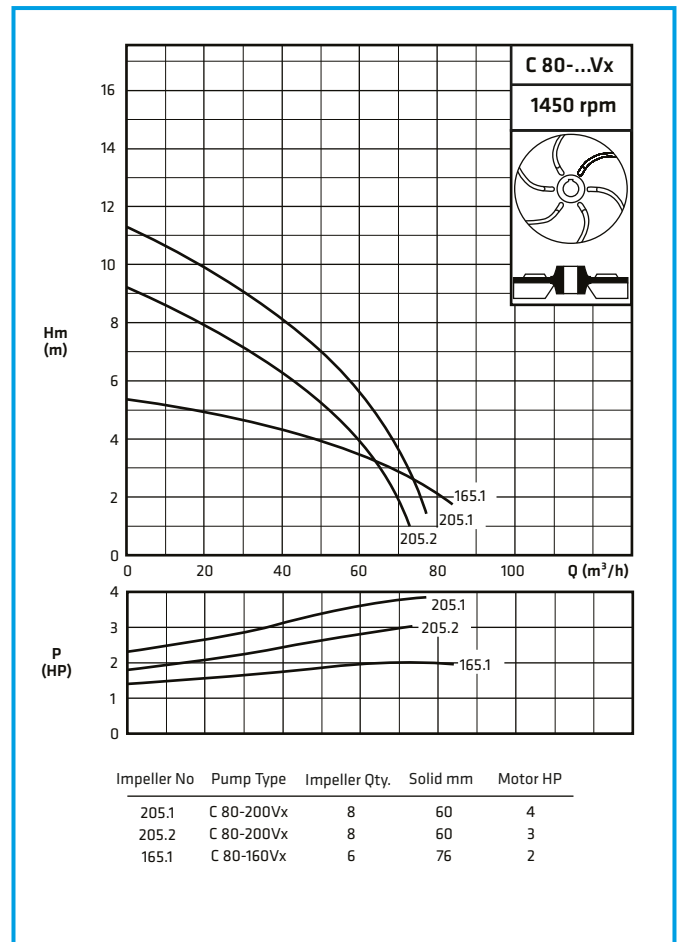
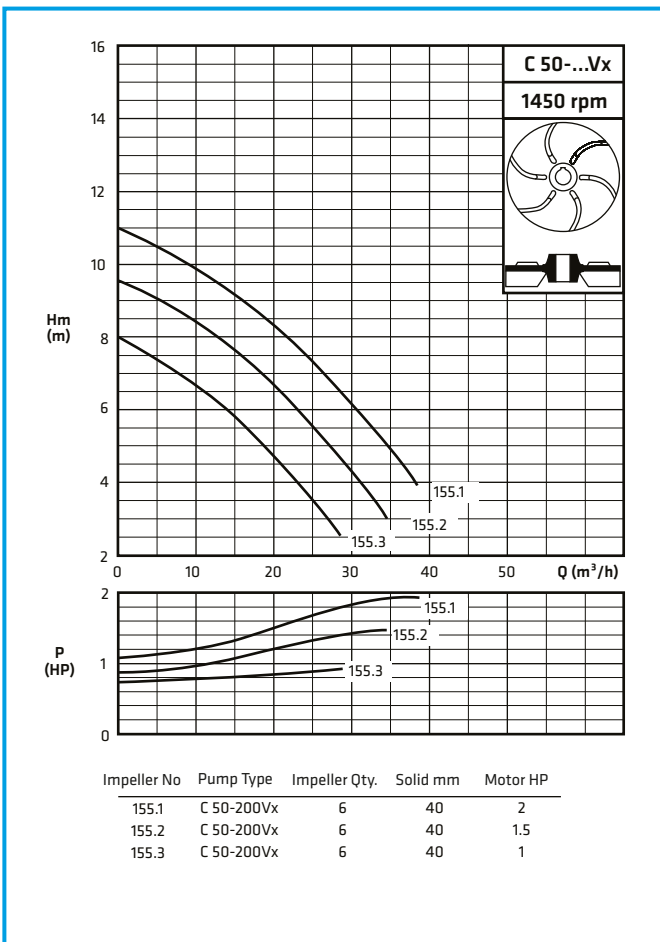
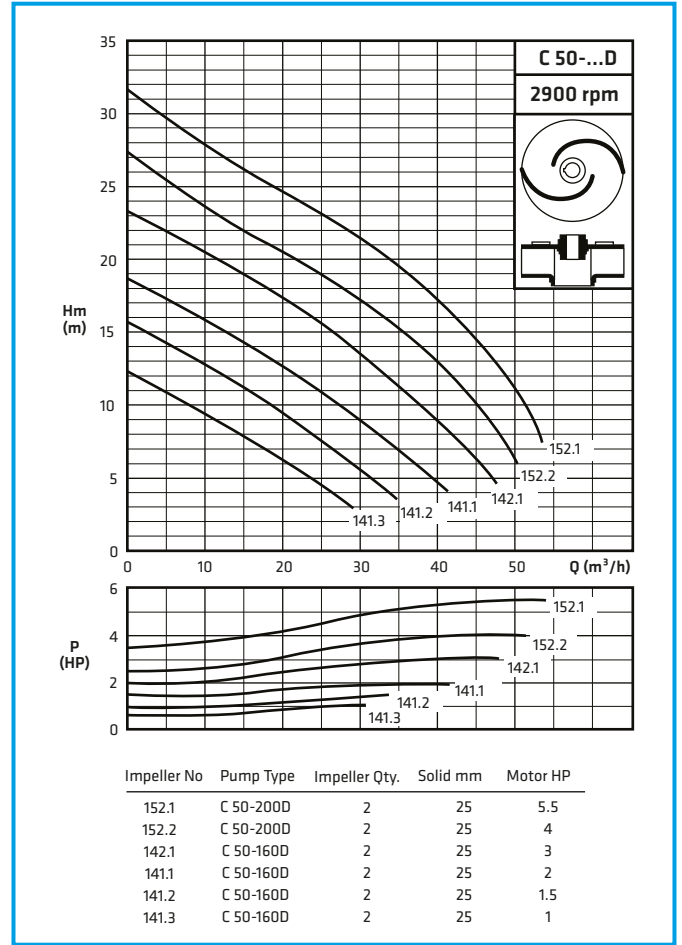
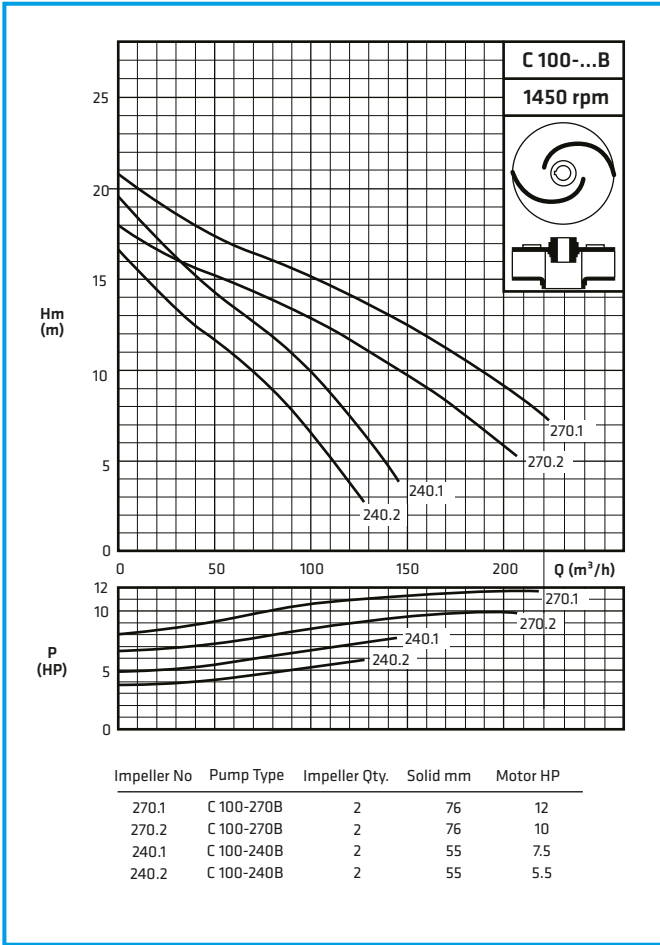

Çalışma Alanları

C

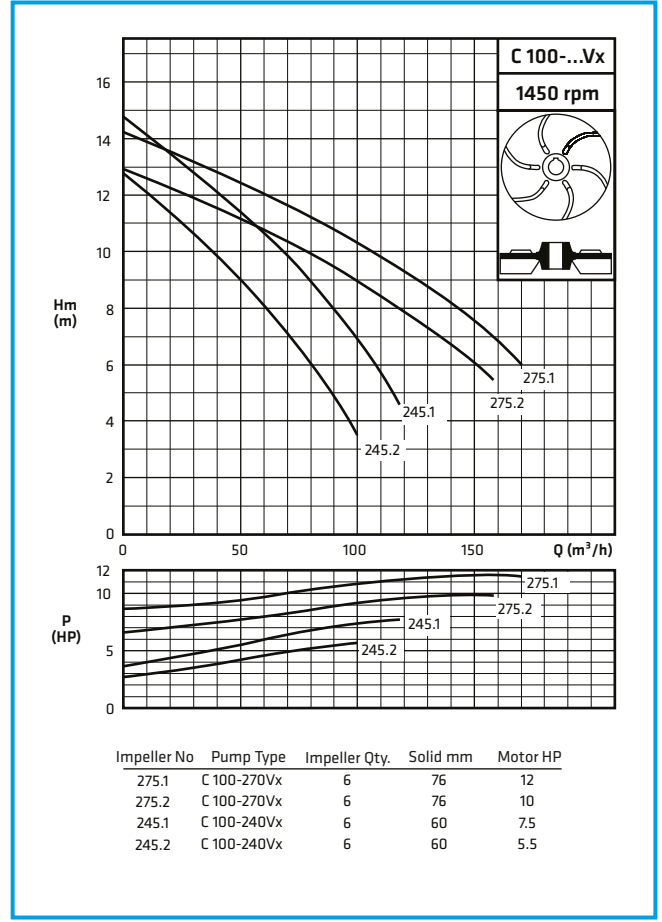
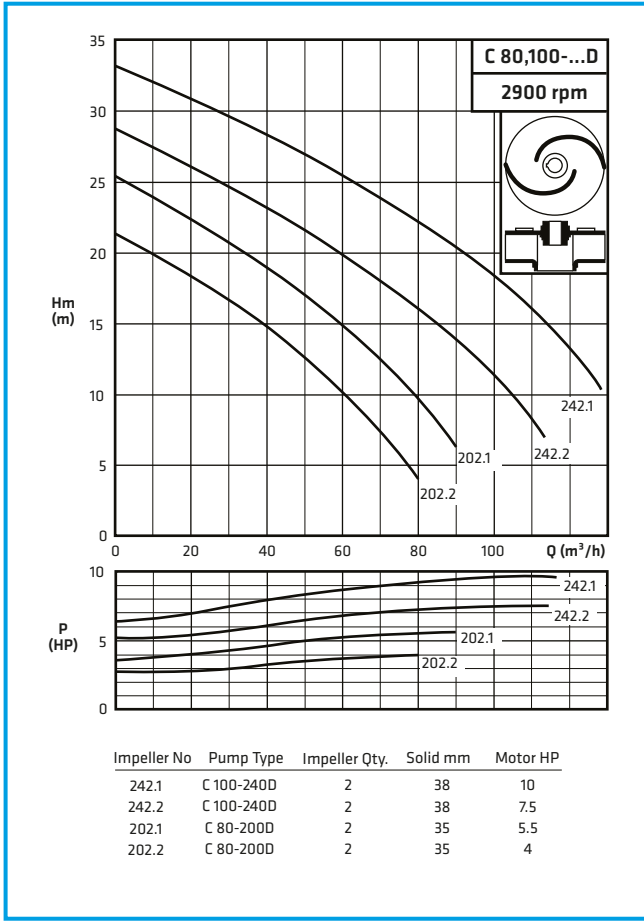

Material Options

PART LIST	0.6025	0.7040	1.0619	1.4308	1.4309	1.4408	1.4409	1.4517	1.4317	2.1050.01	2.0975.01	1.4021
Volute Casing	●	○	○	○	○	○	○	○	○	○		
Motor Casing	●	○		○	○	○						
Impeller	●	○	○	○	○	○	○	○	○	○	○	
Rotor Shaft												●
Oil Chamber	●	○										
Mechanical Seal	EN 12756 / DIN 24960											

● Standard manufacturing
○ Optional

Material Equivalents

Description	DIN / EN		AISI / SAE / ASTM
Cast Iron	0.6025	EN-GJL-250 (GG25)	A48 Class 40B
Nodular Cast Iron	0.7040	EN-GJS-400-15 (GGG40)	A536 60-40-18
Cast Steel	1.0619	GP240GHGS-C25	A216 WCB
Chrome Nickel Cast Steel	1.4308	GX5CrNi19-10	A351 CF8
Chrome Nickel Cast Steel (low carbon)	1.4309	GX2CrNi19-11	A351 CF3
Chrome Nickel Molybdenum Cast Steel	1.4408	GX5CrNiMo19-11-2	A351 CF8M
Chrome Nickel Molybdenum Cast Steel (low carbon)	1.4409	GX2CrNiMo19-11-2	A351 CF3M
Austenitic - Ferritic Cast Steel (duplex)	1.4517	GX2CrNiMoCuN25-6-3-3	A890 CD4MCuN
Martensitic Stainless Cast Steel	1.4317	GX4CrNi13-4	A352 CA6NM
Cast Bronze (tin alloy)	2.1050.01	G-CuSn10	B427 C90700
Cast Bronze (nickel alloy)	2.0975.01	G-CuAl10Ni	B584 C83600
Chrome Steel	1.4021	X20Cr13	A276 Type 420

Technical Data (up to 12 HP) According to TS 12599

C

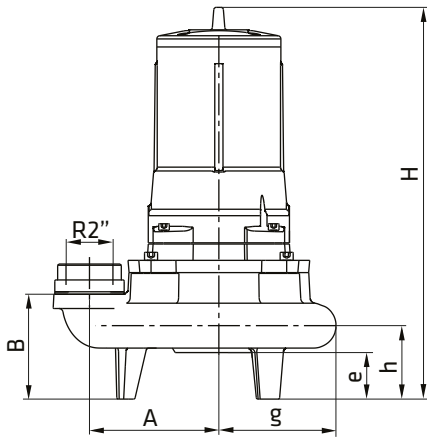

C 50 Hose Connection

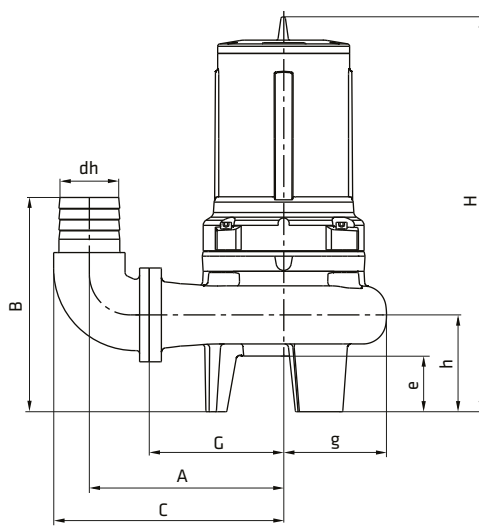

C 80-100 Hose Connection

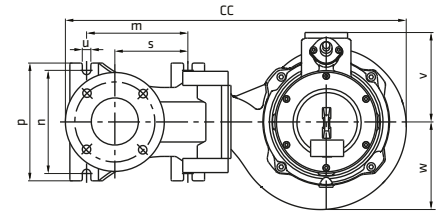
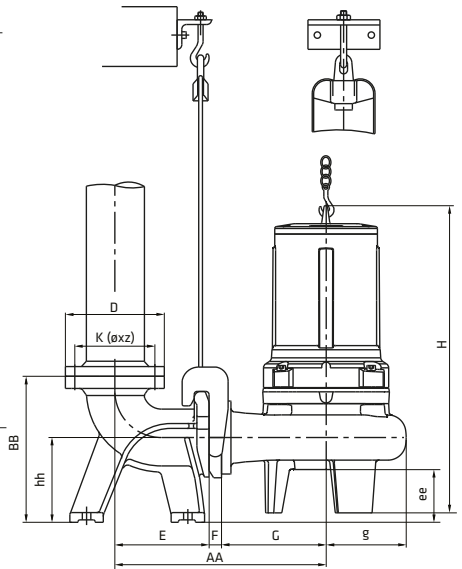

C 50-80-100 Auto Coupling Connection

Pump Type	Impeller Type	MOTOR			DISCHARGE		PUMP DIMENSIONS (mm)										Oil (ml)	Weight (kg)
		Power - HP	IEC No	2900	DN	R"	A	B	C	e	h	H	G	g	v	w		
50-160	Vx	-	1	80	50	2"	139	131	-	55	90	430	185	114	130	125	750	29
50-160	Vx	-	1,5	80	50	2"	139	131	-	55	90	430	185	114	130	125	750	34
50-160	Vx	-	2	90	50	2"	139	131	-	55	90	475	185	114	138	125	750	38
50-160	Vx	-	3	90	50	2"	139	131	-	55	90	475	185	114	138	125	750	41
50-160	D	-	1	80	50	2"	139	131	-	55	90	430	185	114	130	125	750	32
50-160	D	-	1,5	80	50	2"	139	131	-	55	90	430	185	114	130	125	750	34
50-160	D	-	2	90	50	2"	139	131	-	55	90	475	185	114	138	125	750	39
50-160	D	-	3	90	50	2"	139	131	-	55	90	475	185	114	138	125	750	41
50-160	F	-	1,5	80	50	2"	139	131	-	55	90	412	185	114	130	125	750	33
50-160	F	-	2	90	50	2"	139	131	-	55	90	457	185	114	138	125	750	38
50-160	F	-	3	90	50	2"	139	131	-	55	90	457	185	114	138	125	750	40
50-200	Vx	1	-	80	50	2"	160	129	-	57	90	438	205	144	130	152	750	41
50-200	Vx	1,5	-	90	50	2"	160	129	-	57	90	483	205	144	138	152	750	45
50-200	Vx	2	-	90	50	2"	160	129	-	57	90	483	205	144	138	152	750	47
50-200	Vx	-	4	100	50	2"	160	129	-	57	90	524	205	144	148	152	1000	54
50-200	Vx	-	5,5	112	50	2"	160	129	-	57	90	529	205	144	158	152	1000	59
50-200	B	1	-	80	50	2"	160	129	-	57	90	438	205	144	130	152	750	41
50-200	B	1,5	-	90	50	2"	160	129	-	57	90	483	205	144	138	152	750	46
50-200	B	2	-	90	50	2"	160	129	-	57	90	483	205	144	138	152	750	48
50-200	D	-	4	100	50	2"	160	129	-	57	90	524	205	144	148	152	1000	54
50-200	D	-	5,5	112	50	2"	160	129	-	57	90	529	205	144	158	152	1000	60
50-200	F	-	4	100	50	2"	160	129	-	57	90	496	205	144	138	152	1000	52
50-200	F	-	5,5	112	50	2"	160	129	-	57	90	501	205	144	135	152	1000	58
80-160	Vx	2	-	90	80	-	262	287	304	62	133	540	180	130	138	146	1000	58
80-160	B	2	-	90	80	-	262	287	304	62	133	540	180	130	138	146	1000	58
80-200	Vx	4	-	100	80	-	282	286	324	70	132	573	200	150	148	168	1000	62
80-200	Vx	3	-	100	80	-	282	286	324	70	132	573	200	150	148	168	1000	58
80-200	B	4	-	100	80	-	282	286	324	70	132	573	200	150	148	168	1000	64
80-200	B	3	-	100	80	-	282	286	324	70	132	573	200	150	148	168	1000	60
80-200	D	-	4	100	80	-	282	286	324	70	132	573	200	150	148	168	1000	59
80-200	D	-	5,5	112	80	-	282	286	324	70	132	578	200	150	158	168	1000	65
100-240	Vx	5,5	-	112	100	-	324	356	383	94	162	608	225	170	158	186	1000	80
100-240	Vx	7,5	-	132	100	-	324	356	383	94	162	657	225	170	190	186	2000	101
100-240	B	5,5	-	112	100	-	324	356	383	94	162	608	225	170	158	186	1000	82
100-240	B	7,5	-	132	100	-	324	356	383	94	162	657	225	170	190	186	2000	104
100-240	D	-	7,5	132	100	-	324	356	383	94	162	657	225	170	190	186	2000	94
100-240	D	-	10	132	100	-	324	356	383	94	162	657	225	170	190	186	2000	103
100-270	Vx	10	-	132	100	-	359	364	418	88	170	678	260	211	198	228	2000	123
100-270	Vx	12	-	132	100	-	359	364	418	88	170	678	260	211	198	228	2500	123
100-270	B	10	-	132	100	-	359	364	418	88	170	678	260	211	198	228	2500	126
100-270	B	12	-	132	100	-	359	364	418	88	170	678	260	211	198	228	2500	126

Impeller Type

C

B Type Impeller: Enclosed type impellers with wide channels capable of pumping large size solid particles without clogging, for big capacity and low pressure. It is mainly used for 4 pole motors.

D Type Impeller: It is also enclosed type like B type but suitable for high speed motors (2 pole). It is convenient for high pressure, small capacity and smaller size solid particles.

VX Type Impeller: Semi-open free vortex type impeller is placed on top of the volute. It creates a forced vortex motion in the casing. It is mostly suitable for fibrous materials. They are suitable for low head applications but pump efficiency is lower compare to other impeller types. The increased clearances limit the head that can be generated and reduce the attainable efficiency. Recessed type impellers are also possible for some models. With this type of design solid particles up to pump flanges size can pass through the pump. Please ask for more information.

F Type Impeller: Semi-open type impeller with cutter. The cutting system is placed in front of the impeller and it breaks up the solid particles into smaller sizes that makes passing possible through the smaller pipes without sticking. F type impeller is suitable for small capacity, high pressure, but the pump efficiency is also low.

AB Type Impeller: Semi-open type impellers with wide channels capable of pumping large size solid particles without clogging, for big capacity and low pressure. It is more suitable for 4 pole motors. Designed for aggressive applications. Impeller works against a wear plate. Clearance between the wear plate and impeller blades is between 0.25 - 0.40 mm.

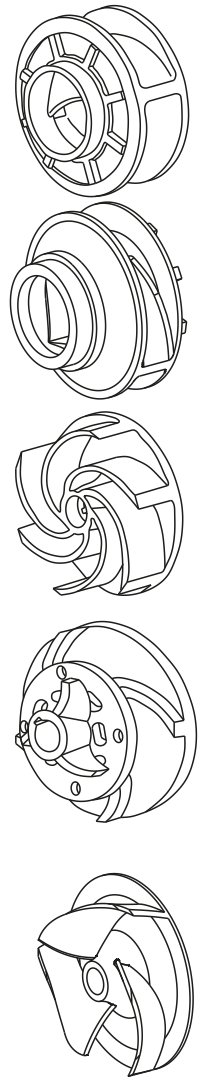

1 - Temperature SENSOR (130°C) in F class winding head protection for overheating.

2 - Signaling ELECTRODE in case of leakage into the motor or into the oil chamber.

3 - Mechanical seal running in pumping liquid.

4 - Demountable TOP COVER for easy motor winding.

5 - Oil filling and inspection PLUG.

6 - BACK VANES for reducing axial load and sealing pressure.

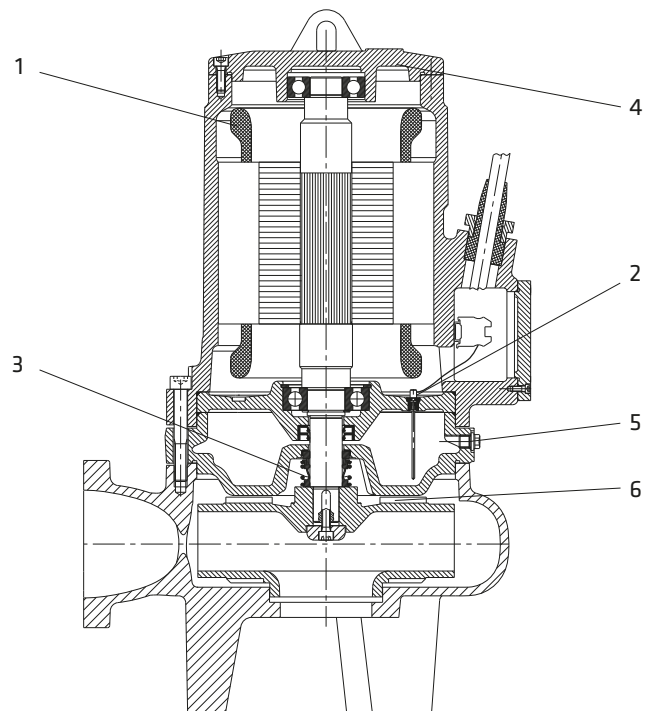

PCST3-V2 MOTOR PROTECTION AND CONTROL RELAY

C

Standart PCST3-V2 Motor Protection and Control Relay is an indispensable part of Standart C type pumps. It is supplied with the pump and it shall be used to secure smooth operation of motor and the pump.

FUNCTION:

When the device is switched on, all indicator lights blink in order and the control unit makes a self-check. If there is not any failure, NORMAL indicator light switches on in green indicating it is ready to run the motor.

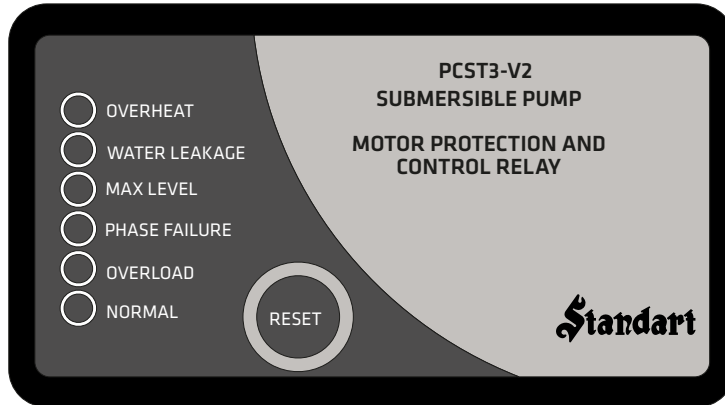

OVER HEAT

In case of overheating of motor windings, in which the temperature exceeds 130°C, the red indicator light switches on and the relay shuts down the motor. Indicator light blinks in short periods at alarming position. When motor has cooled down, relay restarts the motor while alarming goes on until the RESET button is pressed. Pressing the RESET button disables the alarm relay and indicator light stops blinking.

WATER LEAKAGE

In case of water leakage into the motor casing or oil chamber, red indicator light switches on and the relay shuts down the motor. Alarm relay becomes activated and until the RESET button is pressed, alarming goes on by blinking of red indicator light in short periods. When this failure occurs, the pump needs to be overhauled.

MAX LEVEL

When water level reaches the maximum level, which is set by the user, float switch sends on alarm signal and yellow indicator light starts blinking. This alarm does not affect the current state (run or stop) of the pump. Pressing the RESET button disables the alarm relay and indicator light stops blinking.

PHASE FAILURE

An external phase protection relay, mounted in the control panel, is connected to PCST3-V2 for checking phase sequence and phase failures. When there is a failure in mains voltage or in phase sequence, the motor is shut down by the relay and red indicator light starts blinking. By the time the failure is fixed, the motor restarts automatically while alarming goes on until the RESET button is pressed.

OVERLOAD

The relay shuts down the motor, if the current overload limit is exceeded. Meanwhile, alarm relay becomes activated and red indicator light starts blinking. As the failure is fixed, pressing the RESET button will disable the overload and the alarm relay, so the system turns back to normal conditions.

NORMAL

By the time all red indicator lights on PCST3-V2 switch off, green indicator light switches on, meaning that it is ready to run the motor. In case of failure, green indicator light switches off and the relay shuts down the motor.

PCST3-V2 is an indispensable part of Standart C type pumps. If it is damaged, do not try to operate the motor without it.