

C-LOK

Instrument Valve Co., Ltd.

C-LOK THE HIGH QUALITY

instrumentation valves

& fittings specialized production manufacture





The
**High
Quality**
instrumentation
valves **&** fittings specialized
production manufacture

C-LOK

Instrument Valve and Fittings Co., Ltd.

C-LOK



- اتصالات، شیرآلات و تیوب های ابزار دقیق
- محصولات C-LOK دارای تاییدیه شرکت ملی گاز و لیست بلند (AVL) می باشد



C-LOK

Instrument Valve Co., Ltd.

C-LOK the high quality instrumentation valves
& fittings specialized production manufacture

MALE CONNECTOR

CM

Male Connector

2

3



CMG

Male
Connector G

4

5



BCM

Bulkhead Male
Connector

6



TSCW

Tube Socket
Weld Connector

7



MPCW

Male Pipe Weld
Connector

8

9



UNION CONNECTOR

U

Union

10



RU

Reducing Union

11

12



BU

Bulkhead Union

13



TEE CONNECTOR

TU

Tee Union

14



MBT

Male
Branch Tee

15

16



MRT

Male Run Tee

17

18



FBT

Female
Branch Tee

19

20



FRT

Female
Run Tee

21

22



ELBOW CONNECTOR

LM

Male Elbow

23

24



LF

Female Elbow

25

26



LU

Elbow Union

27



FEMALE CONNECTOR

CF

Female
Connector

28

29



CFG

Gauge
Connector

30

31



BCF

Bulkhead
Female
Connector

32



C-LOK

Instrument Valve Co., Ltd.

C-LOK the high quality instrumentation valves & fittings specialized production manufacture

UNION CROSS

CU

Cross Union

33



BF

Back Ferrule

46



PLUG, CAP, VENT

TC

Tube Cap

34



TP

Tube Plug

35



VP

Vent Protectors

36



PIPE FITTING

PI

Hex Plugs

48



PC

Pipe Caps

48



PHN

Hex Nipples

49



PLN

Hex Long Nipples

50



PRB

Reducing Bushings

51



PT

Female Tees

52



PMT

Male Tees

52



PA

Adapters

53



PSE

Street Elbows

54



PE

Female Elbows

55



TUBE STUBE CONNECTOR

AF

Female Adapter

37



AM

Male Adapter

39



R

Reducer

41



P

Port Connector

43



SPARE PARTS

NUT

Nut

44



FF

Front Ferrule

45



C-LOK

Instrument Valve Co., Ltd.

C-LOK the high quality instrumentation valves & fittings specialized production manufacture

PME

Male Elbows 55



PCG

Hex Couplings 56



B2 SERIES

Hex Bar Stock 78
Ball Valves 80



B3 SERIES

Trunnion 81
Ball Valves 82, 83, 84



NEEDLE VALVE

V1 SERIES

General Purpose Needle Valve 58, 59, 60



V4 SERIES

Bar Stock Needle Valve 61, 62, 63, 64, 65



V5 SERIES

Hexagonal Bar Stock Needle Valve 66, 67, 68, 69, 70



V10 SERIES

Toggle Valves 71, 72, 73



GAUGE VALVE & INSTRUMENT MANIFOLDS

2D

Two Valves Manifolds 86, 87, 88, 89, 90



3D

Three Valves Manifolds 91, 92



5D

Five Valves Manifolds 93, 94



BALL VALVES

B1 SERIES

One-pieces Ball Valves 75, 76, 77



GV

Gauge Valves 95



C-LOK

Instrument Valve Co., Ltd.

C-LOK the high quality instrumentation valves & fittings specialized production manufacture

CHECK VALVES

C	97	
Check Valve	98	
	99	
	100	
	101	
	102	
	103	
	104	
	105	

OTHER PRODUCTS

15 Series Tube Fitting	117	
---------------------------	-----	--

20 Series Tube Fittings	118	
----------------------------	-----	---

RELIEF VALVES

R1	107	
Relief Valve	108	
	109	

60 Series Tube Fitting	119	
---------------------------	-----	---

FILTERS

F	111	
Filters	112	
	113	

Bellows Valves S1 S2-9.16	120	
------------------------------	-----	---

TUBE SERIES



TUBE	115
	116

Block and Bleed Valves	121	
---------------------------	-----	---

C-LOK

Instrument Valve Co., Ltd.

C-LOK the high quality instrumentation valves & fittings specialized production manufacture





TUBE FITTING



C-LOK the high quality
instrumentation valves
& fittings specialized
production manufacture

C-LOK

Instrument Valve Co., Ltd.

C-LOK the high quality instrumentation valves
& fittings specialized production manufacture



Male Connector

CM

Connect fractional tube to female NPT thread

Part Number	Tube O.D.		T NPT
	inch	mm	
CM-S1-NT1	1/16	1.58	1/16
CM-S2-NT2	1/8	3.17	1/8
CM-S2-NT4	1/8	3.17	1/4
CM-S2-NT6	1/8	3.17	3/8
CM-S2-NT8	1/8	3.17	1/2
CM-S4-NT2	1/4	6.35	1/8
CM-S4-NT4	1/4	6.35	1/4
CM-S4-NT6	1/4	6.35	3/8
CM-S4-NT8	1/4	6.35	1/2
CM-S4-NT12	1/4	6.35	3/4
CM-S6-NT2	3/8	9.52	1/8
CM-S6-NT4	3/8	9.52	1/4
CM-S6-NT6	3/8	9.52	3/8
CM-S6-NT8	3/8	9.52	1/2
CM-S6-NT12	3/8	9.52	3/4
CM-S8-NT2	1/2	12.70	1/8
CM-S8-NT4	1/2	12.70	1/4
CM-S8-NT6	1/2	12.70	3/8
CM-S8-NT8	1/2	12.70	1/2
CM-S8-NT12	1/2	12.70	3/4
CM-S8-NT16	1/2	12.70	1
CM-S12-NT8	3/4	19.05	1/2
CM-S12-NT12	3/4	19.05	3/4
CM-S12-NT16	3/4	19.05	1
CM-S16-NT8	1	25.40	1/2
CM-S16-NT12	1	25.40	3/4
CM-S16-NT16	1	25.40	1



C-LOK

Instrument Valve Co., Ltd.

C-LOK the high quality instrumentation valves & fittings specialized production manufacture

Male Connector

CM

Connect Metric tube to female NPT thread



Part Number	Tube O.D.	T NPT
CM -SM4-NT2	4	1/8
CM -SM4-NT4	4	1/4
CM -SM6-NT2	6	1/8
CM -SM6-NT4	6	1/4
CM -SM6-NT6	6	3/8
CM -SM6-NT8	6	1/2
CM -SM8-NT2	8	1/8
CM -SM8-NT4	8	1/4
CM -SM8-NT6	8	3/8
CM -SM8-NT8	8	1/2
CM -SM10-NT2	10	1/8
CM -SM10-NT4	10	1/4
CM -SM10-NT6	10	3/8
CM -SM10-NT8	10	1/2
CM -SM12-NT4	12	1/4
CM -SM12-NT6	12	3/8
CM -SM12-NT8	12	1/2
CM -SM12-NT12	12	3/4
CM -SM15-NT8	15	1/2
CM -SM16-NT4	16	1/4
CM -SM16-NT6	16	3/8
CM -SM16-NT8	16	1/2
CM -SM16-NT12	16	3/4
CM -SM18-NT8	18	1/2
CM -SM18-NT12	18	3/4
CM -SM20-NT8	20	1/2
CM -SM20-NT12	20	3/4
CM -SM22-NT12	22	3/4
CM -SM22-NT16	22	1
CM -SM25-NT12	25	3/4
CM -SM25-NT16	25	1





Male Connector G

CMG

Connect fractional tube to female ISO parallel thread(RS)

Part Number	Tube O.D.		T RS
	inch	mm	
CM-S2-RS2	1/8	3.17	1/8
CM-S2-RS4	1/8	3.17	1/4
CM-S2-RS6	1/8	3.17	3/8
CM-S4-RS2	1/4	6.35	1/8
CM-S4-RS4	1/4	6.35	1/4
CM-S4-RS6	1/4	6.35	3/8
CM-S4-RS8	1/4	6.35	1/2
CM-S6-RS4	3/8	9.53	1/4
CM-S6-RS6	3/8	9.53	3/8
CM-S6-RS8	3/8	9.53	1/2
CM-S8-RS4	1/2	12.70	1/4
CM-S8-RS6	1/2	12.70	3/8
CM-S8-RS8	1/2	12.70	1/2
CM-S12-RS8	3/4	19.05	1/2
CM-S12-RS12	3/4	19.05	3/4
CM-S16-RS8	1	25.40	1/2
CM-S16-RS12	1	25.40	3/4
CM-S16-RS16	1	25.40	1



Male Connector G

CMG

Connect Metric tube to female ISO parallel thread (RS)

Part Number	Tube O.D.	T RS
CM - SM4 - RS2	4	1/8
CM - SM4 - RS4	4	1/4
CM - SM6 - RS2	6	1/8
CM - SM6 - RS4	6	1/4
CM - SM6 - RS6	6	3/8
CM - SM6 - RS8	6	1/2
CM - SM8 - RS2	8	1/8
CM - SM8 - RS4	8	1/4
CM - SM8 - RS6	8	3/8
CM - SM8 - RS8	8	1/2
CM - SM10 - RS4	10	1/4
CM - SM10 - RS6	10	3/8
CM - SM10 - RS8	10	1/2
CM - SM12 - RS4	12	1/4
CM - SM12 - RS6	12	3/8
CM - SM12 - RS8	12	1/2
CM - SM12 - RS12	12	3/4
CM - SM16 - RS6	16	3/8
CM - SM16 - RS8	16	1/2
CM - SM18 - RS8	18	1/2
CM - SM18 - RS12	18	3/4
CM - SM20 - RS8	20	1/2
CM - SM20 - RS12	20	3/4
CM - SM22 - RS12	22	3/4
CM - SM22 - RS16	22	1
CM - SM25 - RS12	25	3/4
CM - SM25 - RS16	25	1

C-LOK

Instrument Valve Co., Ltd.

C-LOK the high quality instrumentation valves
& fittings specialized production manufacture



Bulkhead Male Connector

BCM

Connect fractional tube to female NPT thread

Part Number	Tube O.D.		T NPT
	inch	mm	
BCM -S1-NT1	1/16	1.58	1/16
BCM -S2-NT2	1/8	3.17	1/8
BCM -S4-NT2	1/4	6.35	1/8
BCM -S4-NT4	1/4	6.35	1/4
BCM -S6-NT4	3/8	9.52	1/4
BCM -S6-NT6	3/8	9.52	3/8
BCM -S6-NT8	3/8	9.52	1/2
BCM -S8-NT6	1/2	12.70	3/8
BCM -S8-NT8	1/2	12.70	1/2
BCM -S12-NT12	3/4	19.05	3/4
BCM -S16-NT16	1	25.40	1



Tube Socket Weld Connector

TSCW

Connect fractional tube to Socket Weld

Part Number	Tube O.D.	
	inch	mm
TSCW 2 - 2	1/8	3.17
TSCW 4 - 4	1/4	6.35
TSCW 6 - 6	3/8	9.52
TSCW 8 - 8	1/2	12.70
TSCW 12 - 12	3/4	19.05
TSCW 16 - 16	1	25.40



Male Pipe Weld Connector

MPCW

Connect fractional tube to Pipe Weld

Part Number	Tube O.D.		Male Pipe Size	
	inch	mm	Nom.	
PCW -S2-P2	1/8	3.17	1/8	10.29
PCW -S4-P2	1/4	6.35	1/8	10.29
PCW -S4-P4	1/4	6.35	1/4	13.72
PCW -S6-P4	3/8	9.52	1/4	13.72
PCW -S6-P6	3/8	9.52	3/8	17.15
PCW -S6-P8	3/8	9.52	1/2	21.34
PCW -S8-P6	1/2	12.70	3/8	17.15
PCW -S8-P8	1/2	12.70	1/2	21.34
PCW -S8-P12	1/2	12.70	3/4	26.67
PCW -S12-P12	3/4	19.05	3/4	26.67
PCW -S16-P16	1	25.40	1	33.40



Male pipe Weld Connector

MPCW

Connect Metric tube to pipe weld

Part Number	Tube O.D.	Male Pipe Size	
		Nom.	O.D
PCW - SM4 - P2	4	1/8	10.29
PCW - SM6 - P2	6	1/8	10.29
PCW - SM6 - P4	6	1/4	13.72
PCW - SM8 - P2	8	1/8	10.29
PCW - SM8 - P4	8	1/4	13.72
PCW - SM8 - P8	8	1/2	21.34
PCW - SM10 - P4	10	1/4	13.72
PCW - SM10 - P6	10	3/8	17.15
PCW - SM10 - P8	10	1/2	21.34
PCW - SM12 - P4	12	1/4	13.72
PCW - SM12 - P6	12	3/8	17.15
PCW - SM12 - P8	12	1/2	21.34
PCW - SM14 - P6	14	3/8	17.15
PCW - SM15 - P8	15	1/2	21.34
PCW - SM16 - P8	16	1/2	21.34
PCW - SM18 - P8	18	1/2	21.34

C-LOK

Instrument Valve Co., Ltd.

C-LOK the high quality instrumentation valves & fittings specialized production manufacture



Union

U
Connect fractional tube

Part Number	Tube O.D.	
	inch	mm
U - S1	1/16	1.58
U - S2	1/8	3.17
U - S4	1/4	6.35
U - S6	3/8	9.52
U - S8	1/2	12.7
U - S12	3/4	19.05
U - S16	1	25.4



Union

U
Connect Metric tube

Part Number	Tube O.D. inch
U - SM4	4
U - SM6	6
U - SM8	8
U - SM10	10
U - SM12	12
U - SM15	15
U - SM16	16
U - SM18	18
U - SM20	20
U - SM22	22
U - SM25	25



C-LOK

Instrument Valve Co., Ltd.

C-LOK the high quality instrumentation valves & fittings specialized production manufacture



Reducing Union

RU

Connect fractional tube

Part Number	Tube O.D.		Tube O.D.	
	inch	mm	inch	mm
RU - S4 - S2	1/4	6.35	1/8	3.17
RU - S6 - S2	3/8	9.25	1/8	3.17
RU - S6 - S4	3/8	9.25	1/4	6.35
RU - S8 - S2	1/2	12.70	1/8	3.17
RU - S8 - S4	1/2	12.70	1/4	6.35
RU - S8 - S6	1/2	12.70	3/8	9.52
RU - S12 - S4	3/4	19.05	1/4	6.35
RU - S12 - S6	3/4	19.05	3/8	9.52
RU - S12 - S8	3/4	19.05	1/2	12.70
RU - S16 - S8	1	25.40	1/2	12.70
RU - S16 - S12	1	25.40	3/4	19.05



Reducing Union

RU

Connect metric tube

Part Number	Tube O.D.	Tube O.D.
RU - SM6 - SM4	6	4
RU - SM8 - SM6	8	6
RU - SM10 - SM6	10	6
RU - SM10 - SM8	10	8
RU - SM12 - SM6	12	6
RU - SM12 - SM8	12	8
RU - SM12 - SM10	12	10
RU - SM16 - SM10	16	10
RU - SM16 - SM12	16	12
RU - SM18 - SM12	18	12
RU - SM25 - SM18	25	18
RU - SM25 - SM20	25	20





Reducing Union

RU

Connect Metric tube to fractional tube

Part Number	Tube O.D.	Tube O.D.	
		inch	mm
RU - SM4 - S2	4	1/8	3.17
RU - SM4 - S4	4	1/4	6.35
RU - SM6 - S2	6	1/8	3.17
RU - SM6 - S4	6	1/4	6.35
RU - SM8 - S4	8	1/4	6.35
RU - SM10 - S2	10	1/8	3.17
RU - SM10 - S4	10	1/4	6.35
RU - SM10 - S6	10	3/8	9.52
RU - SM12 - S6	12	3/8	9.52
RU - SM12 - S8	12	1/2	12.70
RU - SM15 - S8	15	1/2	12.70
RU - SM18 - S12	18	3/4	19.05
RU - SM20 - S12	20	3/4	19.05
RU - SM20 - S16	20	1	25.40
RU - SM22 - S16	22	1	25.40



Bulkhead Union

BU

Connect fractional tube

Part Number	Tube O.D.	
	inch	mm
BU - S2	1/8	3.17
BU - S4	1/4	6.35
BU - S6	3/8	9.25
BU - S8	1/2	12.70
BU - S12	3/4	19.05
BU - S16	1	25.40



Bulkhead Union

BU

Connect metric tube

Part Number	Tube O.D.
BU - SM4	4
BU - SM6	6
BU - SM8	8
BU - SM10	10
BU - SM12	12
BU - SM15	15
BU - SM16	16
BU - SM18	18
BU - SM20	20
BU - SM22	22
BU - SM25	25

C-LOK

Instrument Valve Co., Ltd.

C-LOK the high quality instrumentation valves & fittings specialized production manufacture

Tee Union

TU

Connect fractional tube



Part Number	Tube O.D.	
	inch	mm
TU - S1	1/16	1.58
TU - S2	1/8	3.17
TU - S4	1/4	6.35
TU - S6	3/8	9.52
TU - S8	1/2	12.70
TU - S12	3/4	19.05
TU - S16	1	25.40

Tee Union

TU

Connect metric tube



Part Number	Tube O.D.
TU - SM4	4
TU - SM6	6
TU - SM8	8
TU - SM10	10
TU - SM12	12
TU - SM15	15
TU - SM16	16
TU - SM18	18
TU - SM20	20
TU - SM22	22
TU - SM25	25



Male Branch Tee

MBT

Connect fractional tube to female NPT thread

Part Number	Tube O.D.		T NPT
	inch	mm	
MBT -S2-NT2	1/8	3.17	1/8
MBT -S2-NT4	1/8	3.17	1/4
MBT -S4-NT1	1/4	6.35	1/16
MBT -S4-NT2	1/4	6.35	1/8
MBT -S4-NT4	1/4	6.35	1/4
MBT -S4-NT6	1/4	6.35	3/8
MBT -S4-NT8	1/4	6.35	1/2
MBT -S6-NT4	3/8	9.52	1/4
MBT -S6-NT6	3/8	9.52	3/8
MBT -S6-NT8	3/8	9.52	1/2
MBT -S6-NT12	3/8	9.52	3/4
MBT -S8-NT4	1/2	12.70	1/4
MBT -S8-NT6	1/2	12.70	3/8
MBT -S8-NT8	1/2	12.70	1/2
MBT -S8-NT12	1/2	12.70	3/4
MBT -S12-NT8	3/4	19.05	1/2
MBT -S12-NT12	3/4	19.05	3/4
MBT -S16-NT12	1	25.40	3/4
MBT -S16-NT16	1	25.40	1

C-LOK

Instrument Valve Co., Ltd.

C-LOK the high quality instrumentation valves & fittings specialized production manufacture



Male Branch Tee

MBT

Connect Metric tube to female NPT thread

Part Number	Tube O.D.	T NPT
MBT - SM4 - NT2	4	1/8
MBT - SM4 - NT4	4	1/4
MBT - SM6 - NT2	6	1/8
MBT - SM6 - NT4	6	1/4
MBT - SM6 - NT6	6	3/8
MBT - SM6 - NT8	6	1/2
MBT - SM8 - NT2	8	1/8
MBT - SM8 - NT4	8	1/4
MBT - SM8 - NT6	8	3/8
MBT - SM8 - NT8	8	1/2
MBT - SM10 - NT2	10	1/8
MBT - SM10 - NT4	10	1/4
MBT - SM10 - NT6	10	3/8
MBT - SM10 - NT8	10	1/2
MBT - SM12 - NT2	12	1/8
MBT - SM12 - NT4	12	1/4
MBT - SM12 - NT6	12	3/8
MBT - SM12 - NT8	12	1/2
MBT - SM12 - NT12	12	3/4
MBT - SM16 - NT6	16	3/8
MBT - SM16 - NT8	16	1/2
MBT - SM16 - NT12	16	3/4
MBT - SM18 - NT8	18	1/2
MBT - SM18 - NT12	18	3/4
MBT - SM20 - NT8	20	1/2
MBT - SM20 - NT12	20	3/4
MBT - SM22 - NT12	22	3/4
MBT - SM22 - NT16	22	1
MBT - SM25 - NT12	25	3/4
MBT - SM25 - NT16	25	1





Male Run Tee

MRT

Connect fractional tube to female NPT thread

Part Number	Tube O.D.		T NPT
	inch	mm	
MRT -S2-NT2	1/8	3.17	1/8
MRT -S2-NT4	1/8	3.17	1/4
MRT -S4-NT1	1/4	6.35	1/16
MRT -S4-NT2	1/4	6.35	1/8
MRT -S4-NT4	1/4	6.35	1/4
MRT -S4-NT6	1/4	6.35	3/8
MRT -S4-NT8	1/4	6.35	1/2
MRT -S6-NT4	3/8	9.52	1/4
MRT -S6-NT6	3/8	9.52	3/8
MRT -S6-NT8	3/8	9.52	1/2
MRT -S6-NT12	3/8	9.52	3/4
MRT -S8-NT4	1/2	12.70	1/4
MRT -S8-NT6	1/2	12.70	3/8
MRT -S8-NT8	1/2	12.70	1/2
MRT -S8-NT12	1/2	12.70	3/4
MRT -S12-NT8	3/4	19.05	1/2
MRT -S12-NT12	3/4	19.05	3/4
MRT -S16-NT12	1	25.40	3/4
MRT -S16-NT16	1	25.40	1

C-LOK

Instrument Valve Co., Ltd.

C-LOK the high quality instrumentation valves & fittings specialized production manufacture



Male Run Tee

MRT

Connect Metric tube to female NPT thread

Part Number	Tube O.D.	T NPT
MRT -SM4-NT2	4	1/8
MRT -SM4-NT4	4	1/4
MRT -SM6-NT2	6	1/8
MRT -SM6-NT4	6	1/4
MRT -SM6-NT6	6	3/8
MRT -SM6-NT8	6	1/2
MRT -SM8-NT2	8	1/8
MRT -SM8-NT4	8	1/4
MRT -SM8-NT6	8	3/8
MRT -SM8-NT8	8	1/2
MRT -SM10-NT2	10	1/8
MRT -SM10-NT4	10	1/4
MRT -SM10-NT6	10	3/8
MRT -SM10-NT8	10	1/2
MRT -SM12-NT2	12	1/8
MRT -SM12-NT4	12	1/4
MRT -SM12-NT6	12	3/8
MRT -SM12-NT8	12	1/2
MRT -SM12-NT12	12	3/4
MRT -SM16-NT6	16	3/8
MRT -SM16-NT8	16	1/2
MRT -SM16-NT12	16	3/4
MRT -SM18-NT8	18	1/2
MRT -SM18-NT12	18	3/4
MRT -SM20-NT8	20	1/2
MRT -SM20-NT12	20	3/4
MRT -SM22-NT12	22	3/4
MRT -SM22-NT16	22	1
MRT -SM25-NT12	25	3/4
MRT -SM25-NT16	25	1





Female Branch Tee

FBT

Connect fractional tube to male NPT thread

Part Number	Tube O.D.		T NPT
	inch	mm	
FBT - S2 - NT2	1/8	3.17	1/8
FBT - S2 - NT4	1/8	3.17	1/4
FBT - S4 - NT2	1/4	6.35	1/8
FBT - S4 - NT4	1/4	6.35	1/4
FBT - S4 - NT6	1/4	6.35	3/8
FBT - S4 - NT8	1/4	6.35	1/2
FBT - S6 - NT2	3/8	9.52	1/8
FBT - S6 - NT4	3/8	9.52	1/4
FBT - S6 - NT6	3/8	9.52	3/8
FBT - S6 - NT8	3/8	9.52	1/2
FBT - S8 - NT4	1/2	12.70	1/4
FBT - S8 - NT6	1/2	12.70	3/8
FBT - S8 - NT8	1/2	12.70	1/2
FBT - S12 - NT8	3/4	19.05	1/2
FBT - S12 - NT12	3/4	19.05	3/4
FBT - S16 - NT12	1	25.40	3/4
FBT - S16 - NT16	1	25.40	1



Female Branch Tee

FBT

Connect Metric tube to male NPT thread

Part Number	Tube O.D.	T NPT
FBT -SM6-NT2	6	1/8
FBT -SM6-NT4	6	1/4
FBT -SM6-NT6	6	3/8
FBT -SM6-NT8	6	1/2
FBT -SM8-NT2	8	1/8
FBT -SM8-NT4	8	1/4
FBT -SM8-NT6	8	3/8
FBT -SM8-NT8	8	1/2
FBT -SM10-NT2	10	1/8
FBT -SM10-NT4	10	1/4
FBT -SM10-NT6	10	3/8
FBT -SM10-NT8	10	1/2
FBT -SM12-NT4	12	1/4
FBT -SM12-NT6	12	3/8
FBT -SM12-NT8	12	1/2
FBT-SM16-NT8	16	1/2



Female Run Tee

FRT

Connect fractional tube to male NPT thread

Part Number	Tube O.D.		T NPT
	inch	mm	
FRT -S2-NT2	1/8	3.17	1/8
FRT -S2-NT4	1/8	3.17	1/4
FRT -S4-NT2	1/4	6.35	1/8
FRT -S4-NT4	1/4	6.35	1/4
FRT -S4-NT6	1/4	6.35	3/8
FRT -S4-NT8	1/4	6.35	1/2
FRT -S6-NT2	3/8	9.52	1/8
FRT -S6-NT4	3/8	9.52	1/4
FRT -S6-NT6	3/8	9.52	3/8
FRT -S6-NT8	3/8	9.52	1/2
FRT -S8-NT4	1/2	12.70	1/4
FRT -S8-NT6	1/2	12.70	3/8
FRT -S8-NT8	1/2	12.70	1/2
FRT -S12-NT8	3/4	19.05	1/2
FRT -S12-NT12	3/4	19.05	3/4
FRT -S16-NT12	1	25.40	3/4
FRT -S16-NT16	1	25.40	1



Female Run Tee

FRT

Connect metric tube to male NPT thread

Part Number	Tube O.D.	T NPT
FRT -SM6-NT2	6	1/8
FRT -SM6-NT4	6	1/4
FRT -SM6-NT6	6	3/8
FRT -SM6-NT8	6	1/2
FRT -SM8-NT2	8	1/8
FRT -SM8-NT4	8	1/4
FRT -SM8-NT6	8	3/8
FRT -SM8-NT8	8	1/2
FRT -SM10-NT2	10	1/8
FRT -SM10-NT4	10	1/4
FRT -SM10-NT6	10	3/8
FRT -SM10-NT8	10	1/2
FRT -SM12-NT4	12	1/4
FRT -SM12-NT6	12	3/8
FRT -SM12-NT8	12	1/2
FRT-SM16-NT8	16	1/2



Male Elbow

LM

Connect fractional to Female NPT thread

Part Number	Tube O.D.		T NPT
	inch	mm	
LM - S1 - NT1	1/16	1.58	1/16
LM - S2 - NT2	1/8	3.17	1/8
LM - S2 - NT4	1/8	3.17	1/4
LM - S4 - NT1	1/4	6.35	1/16
LM - S4 - NT2	1/4	6.35	1/8
LM - S4 - NT4	1/4	6.35	1/4
LM - S4 - NT6	1/4	6.35	3/8
LM - S4 - NT8	1/4	6.35	1/2
LM - S6 - NT2	3/8	9.52	1/8
LM - S6 - NT4	3/8	9.52	1/4
LM - S6 - NT6	3/8	9.52	3/8
LM - S6 - NT8	3/8	9.52	1/2
LM - S6 - NT12	3/8	9.52	3/4
LM - S8 - NT4	1/2	12.70	1/4
LM - S8 - NT6	1/2	12.70	3/8
LM - S8 - NT8	1/2	12.70	1/2
LM - S8 - NT12	1/2	12.70	3/4
LM - S12 - NT8	3/4	19.05	1/2
LM - S12 - NT12	3/4	19.05	3/4
LM - S16 - NT12	1	25.40	3/4
LM - S16 - NT16	1	25.40	1

C-LOK

Instrument Valve Co., Ltd.

C-LOK the high quality instrumentation valves & fittings specialized production manufacture



Male Elbow

LM

Connect Metric tube to female NPT thread

Part Number	Tube O.D.	T NPT
LM - SM4 - NT2	4	1/8
LM - SM4 - NT4	4	1/4
LM - SM6 - NT2	6	1/8
LM - SM6 - NT4	6	1/4
LM - SM6 - NT6	6	3/8
LM - SM6 - NT8	6	1/2
LM - SM8 - NT2	8	1/8
LM - SM8 - NT4	8	1/4
LM - SM8 - NT6	8	3/8
LM - SM8 - NT8	8	1/2
LM - SM10 - NT2	10	1/8
LM - SM10 - NT4	10	1/4
LM - SM10 - NT6	10	3/8
LM - SM10 - NT8	10	1/2
LM - SM12 - NT2	12	1/8
LM - SM12 - NT4	12	1/4
LM - SM12 - NT6	12	3/8
LM - SM12 - NT8	12	1/2
LM - SM12 - NT12	12	3/4
LM - SM16 - NT6	16	3/8
LM - SM16 - NT8	16	1/2
LM - SM16 - NT12	16	3/4
LM - SM18 - NT8	18	1/2
LM - SM18 - NT12	18	3/4
LM - SM20 - NT8	20	1/2
LM - SM20 - NT12	20	3/4
LM - SM22 - NT12	22	3/4
LM - SM22 - NT16	22	1
LM - SM25 - NT12	25	3/4
LM - SM25 - NT16	25	1





Female Elbow

LF

Connect fractional tube to male NPT thread

Part Number	Tube O.D.		T NPT
	inch	mm	
LF - S1 - NT1	1/16	1.58	1/16
LF - S2 - NT2	1/8	3.17	1/8
LF - S2 - NT4	1/8	3.17	1/4
LF - S4 - NT2	1/4	6.35	1/8
LF - S4 - NT4	1/4	6.35	1/4
LF - S4 - NT6	1/4	6.35	3/8
LF - S4 - NT8	1/4	6.35	1/2
LF - S6 - NT2	3/8	9.52	1/8
LF - S6 - NT4	3/8	9.52	1/4
LF - S6 - NT6	3/8	9.52	3/8
LF - S6 - NT8	3/8	9.52	1/2
LF - S8 - NT4	1/2	12.70	1/4
LF - S8 - NT6	1/2	12.70	3/8
LF - S8 - NT8	1/2	12.70	1/2
LF - S12 - NT8	3/4	19.05	1/2
LF - S12 - NT12	3/4	19.05	3/4
LF - S16 - NT12	1	25.40	3/4
LF - S16 - NT16	1	25.40	1

C-LOK

Instrument Valve Co., Ltd.

C-LOK the high quality instrumentation valves
& fittings specialized production manufacture



Female Elbow

LF

Connect metric tube to male NPT thread

Part Number	Tube O.D.	T NPT
LF - SM6 - NT2	6	1/8
LF - SM6 - NT4	6	1/4
LF - SM6 - NT6	6	3/8
LF - SM6 - NT8	6	1/2
LF - SM8 - NT2	8	1/8
LF - SM8 - NT4	8	1/4
LF - SM8 - NT8	8	1/2
LF - SM10 - NT2	10	1/8
LF - SM10 - NT4	10	1/4
LF - SM10 - NT6	10	3/8
LF - SM10 - NT8	10	1/2
LF - SM12 - NT4	12	1/4
LF - SM12 - NT6	12	3/8
LF - SM12 - NT8	12	1/2
LF - SM16 - NT8	16	1/2



Elbow Union

LU

Connect fractional tube

Part Number	Tube O.D.	
	inch	mm
LU - S1	1/16	1.58
LU - S2	1/8	3.17
LU - S4	1/4	6.35
LU - S6	3/8	9.52
LU - S8	1/2	12.70
LU - S12	3/4	19.05
LU - S16	1	25.40

Elbow Union

LU

Connect metric tube



Part Number	Tube O.D.
LU - SM4	4
LU - SM6	6
LU - SM8	8
LU - SM10	10
LU - SM12	12
LU - SM15	15
LU - SM16	16
LU - SM18	18
LU - SM20	20
LU - SM22	22
LU - SM25	25



Female Connector

CF

Connect fractional tube to male NPT thread

Part Number	Tube O.D.		T NPT
	inch	mm	
CF - S1 - NT1	1/16	1.58	1/16
CF - S2 - NT2	1/8	3.17	1/8
CF - S2 - NT4	1/8	3.17	1/4
CF - S4 - NT2	1/4	6.35	1/8
CF - S4 - NT4	1/4	6.35	1/4
CF - S4 - NT6	1/4	6.35	3/8
CF - S4 - NT8	1/4	6.35	1/2
CF - S6 - NT2	3/8	9.52	1/8
CF - S6 - NT4	3/8	9.52	1/4
CF - S6 - NT6	3/8	9.52	3/8
CF - S6 - NT8	3/8	9.52	1/2
CF - S6 - NT12	3/8	9.52	3/4
CF - S8 - NT4	1/2	12.70	1/4
CF - S8 - NT6	1/2	12.70	3/8
CF - S8 - NT8	1/2	12.70	1/2
CF - S8 - NT12	1/2	12.70	3/4
CF - S12 - NT8	3/4	19.05	1/2
CF - S12 - NT12	3/4	19.05	3/4
CF - S16 - NT12	1	25.40	3/4
CF - S16 - NT16	1	25.40	1

Female Connector

CF

Connect metric tube to male NPT thread



Part Number	Tube O.D.	T NPT
CF - SM4 - NT2	4	1/8
CF - SM6 - NT2	6	1/8
CF - SM6 - NT4	6	1/4
CF - SM6 - NT6	6	3/8
CF - SM6 - NT8	6	1/2
CF - SM8 - NT2	8	1/8
CF - SM8 - NT4	8	1/4
CF - SM8 - NT6	8	3/8
CF - SM8 - NT8	8	1/2
CF - SM10 - NT2	10	1/8
CF - SM10 - NT4	10	1/4
CF - SM10 - NT6	10	3/8
CF - SM10 - NT8	10	1/2
CF - SM12 - NT2	12	1/8
CF - SM12 - NT4	12	1/4
CF - SM12 - NT6	12	3/8
CF - SM12 - NT8	12	1/2
CF - SM12 - NT12	12	3/4
CF - SM15 - NT8	15	1/2
CF - SM16 - NT8	16	1/2
CF - SM20 - NT8	20	1/2
CF - SM20 - NT12	20	3/4
CF - SM22 - NT12	22	3/4
CF - SM22 - NT16	22	1
CF - SM25 - NT12	25	3/4
CF - SM25 - NT16	25	1

C-LOK

Instrument Valve Co., Ltd.

C-LOK the high quality instrumentation valves
& fittings specialized production manufacture



Female Connector G

CFG

Connect fractional tube to male iso tapered thread (RG)

Part Number	Tube O.D.		T RG
	inch	mm	
CF - S4 - RG2	1/4	6.35	1/8
CF - S4 - RG4	1/4	6.35	1/4
CF - S4 - RG6	1/4	6.35	3/8
CF - S4 - RG8	1/4	6.35	1/2
CF - S6 - RG4	3/8	9.52	1/4
CF - S6 - RG6	3/8	9.52	3/8
CF - S6 - RG8	3/8	9.52	1/2
CF - S8 - RG4	1/2	12.70	1/4
CF - S8 - RG6	1/2	12.70	3/8
CF - S8 - RG8	1/2	12.70	1/2



Female Connector G

CFG

Connect metric tube to male ISO tapered thread (RG)

Part Number	Tube O.D.	T RG
CF - SM6 - RG4	6	1/4
CF - SM6 - RG6	6	3/8
CF - SM6 - RG8	6	1/2
CF - SM8 - RG4	8	1/4
CF - SM8 - RG6	8	3/8
CF - SM8 - RG8	8	1/2
CF - SM10 - RG4	10	1/4
CF - SM10 - RG6	10	3/8
CF - SM10 - RG8	10	1/2
CF - SM12 - RG4	12	1/4
CF - SM12 - RG6	12	3/8
CF - SM12 - RG8	12	1/2
CF - SM20 - RG8	20	1/2
CF - SM22 - RG8	22	1/2



Bulkhead Female Connector

BCF

Connect fractional tube to male NPT thread

Part Number	Tube O.D.		T NPT
	inch	mm	
BCF - S2 - NT2	1/8	3.17	1/8
BCF - S4 - NT2	1/4	6.35	1/8
BCF - S4 - NT4	1/4	6.35	1/4
BCF - S6 - NT4	3/8	9.52	1/4
BCF - S6 - NT6	3/8	9.52	3/8
BCF - S8 - NT6	1/2	12.70	3/8
BCF - S8 - NT8	1/2	12.70	1/2
BCF - S12 - NT12	3/4	19.05	3/4
BCF - S16 - NT16	1	25.40	1



Bulkhead Female Connector

BCF

Connect metric tube to male NPT thread

Part Number	Tube O.D.	T NPT
BCF - SM6 - NT2	6	1/8
BCF - SM6 - NT4	6	1/4
BCF - SM8 - NT4	8	1/4
BCF - SM12 - NT8	12	1/2

C-LOK

Instrument Valve Co., Ltd.

C-LOK the high quality instrumentation valves & fittings specialized production manufacture



Cross Union

CU

Connect fractional tube

Part Number	Tube O.D.	
	inch	mm
CU - S2	1/8	3.17
CU - S4	1/4	6.35
CU - S6	3/8	9.52
CU - S8	1/2	12.70
CU - S12	3/4	19.05
CU - S16	1	25.40

Cross Union

CU

Connect metric tube



Part Number	Tube O.D.
CU - SM4	4
CU - SM6	6
CU - SM8	8
CU - SM10	10
CU - SM12	12
CU - SM15	15
CU - SM16	16
CU - SM18	18
CU - SM20	20
CU - SM22	22
CU - SM25	25



C-LOK

Instrument Valve Co., Ltd.

C-LOK the high quality instrumentation valves & fittings specialized production manufacture

Tube Cap

TC

Cap end of Fractional tube



Part Number	Tube O.D.	
	inch	mm
TC - S2	1/8	3.17
TC - S4	1/4	6.35
TC - S6	3/8	9.52
TC - S8	1/2	12.70
TC - S12	3/4	19.05
TC - S16	1	25.40

Tube Cap

TC

Cap end of metric tube



Part Number	Tube O.D. mm
TC - SM2	2
TC - SM3	3
TC - SM4	4
TC - SM6	6
TC - SM8	8
TC - SM10	10
TC - SM12	12
TC - SM15	15
TC - SM16	16
TC - SM18	18
TC - SM20	20
TC - SM22	22
TC - SM25	25

Tube Plug

TP

Fractional



Part Number	Tube O.D.	
	inch	mm
TP - S2	1/8	3.17
TP - S4	1/4	6.35
TP - S6	3/8	9.52
TP - S8	1/2	12.70
TP - S12	3/4	19.05
TP - S16	1	25.40

Tube Plug

TP

Metric



Part Number	Tube O.D. mm
TP - SM4	4
TP - SM6	6
TP - SM8	8
TP - SM10	10
TP - SM12	12
TP - SM15	15
TP - SM16	16
TP - SM18	18
TP - SM20	20
TP - SM22	22
TP - SM25	25

C-LOK

Instrument Valve Co., Ltd.

C-LOK the high quality instrumentation valves
& fittings specialized production manufacture



Vent Protector

VP

Fractional

Part Number	T NPT
VP - NPF - NT2	1/8
VP - NPF - NT4	1/4
VP - NPF - NT6	3/8
VP - NPF - NT8	1/2
VP - NPF - NT12	3/4
VP - NPF - NT16	1



Female Adapter

AF

Connect fractional C-LOK port to male NPT thread

Part Number	Tube O.D.		T NPT
	inch	mm	
AF - FT2 - NT2	1/8	3.17	1/8
AF - FT2 - NT4	1/8	3.17	1/4
AF - FT4 - NT2	1/4	6.35	1/8
AF - FT4 - NT4	1/4	6.35	1/4
AF - FT4 - NT6	1/4	6.35	3/8
AF - FT4 - NT8	1/4	6.35	1/2
AF - FT6 - NT2	3/8	9.52	1/8
AF - FT6 - NT4	3/8	9.52	1/4
AF - FT6 - NT6	3/8	9.52	3/8
AF - FT6 - NT8	3/8	9.52	1/2
AF - FT8 - NT4	1/2	12.70	1/4
AF - FT8 - NT6	1/2	12.70	3/8
AF - FT8 - NT8	1/2	12.70	1/2
AF - FT12 - NT8	3/4	19.05	1/2
AF - FT12 - NT12	3/4	19.05	3/4
AF - FT12 - NT16	3/4	19.05	1
AF - FT16 - NT12	1	25.40	3/4
AF - FT16 - NT16	1	25.40	1



Female Adapter

AF

Connect metric C-LOK port to male NPT thread

Part Number	Tube O.D.	T R (PT)
AF - MT3 - NT2	3	1/8
AF - MT6 - NT2	6	1/8
AF - MT6 - NT4	6	1/4
AF - MT8 - NT4	8	1/4
AF - MT10 - NT4	10	1/4
AF - MT10 - NT6	10	3/8
AF - MT10 - NT8	10	1/2
AF - MT12 - NT4	12	1/4
AF - MT12 - NT6	12	3/8
AF - MT12 - NT8	12	1/2
AF - MT18 - NT12	18	3/4



Male Adapter

AM

Connect fractional C-LOK port to female NPT thread

Part Number	Tube O.D.		T NPT
	inch	mm	
AM - FT2 - NT2	1/8	3.17	1/8
AM - FT2 - NT4	1/8	3.17	1/4
AM - FT4 - NT2	1/4	6.35	1/8
AM - FT4 - NT4	1/4	6.35	1/4
AM - FT4 - NT6	1/4	6.35	3/8
AM - FT4 - NT8	1/4	6.35	1/2
AM - FT6 - NT2	3/8	9.52	1/8
AM - FT6 - NT4	3/8	9.52	1/4
AM - FT6 - NT6	3/8	9.52	3/8
AM - FT6 - NT8	3/8	9.52	1/2
AM - FT8 - NT4	1/2	12.70	1/4
AM - FT8 - NT6	1/2	12.70	3/8
AM - FT8 - NT8	1/2	12.70	1/2
AM - FT12 - NT8	3/4	19.05	1/2
AM - FT12 - NT12	3/4	19.05	3/4
AM - FT12 - NT16	3/4	19.05	1
AM - FT14 - NT12	7/8	22.22	3/4
AM - FT16 - NT12	1	25.40	3/4
AM - FT16 - NT16	1	25.40	1

C-LOK

Instrument Valve Co., Ltd.

C-LOK the high quality instrumentation valves
& fittings specialized production manufacture



Male Adapter

AM

Connect Metric C-LOK port to female NPT thread

Part Number	Tube O.D.	T NPT
AM - MT3 - NT2	3	1/8
AM - MT6 - NT2	6	1/8
AM - MT6 - NT4	6	1/4
AM - MT8 - NT4	8	1/4
AM - MT10 - NT4	10	1/4
AM - MT10 - NT6	10	3/8
AM - MT10 - NT8	10	1/2
AM - MT12 - NT4	12	1/4
AM - MT12 - NT6	12	3/8
AM - MT12 - NT8	12	1/2
AM - MT18 - NT8	18	1/2
AM - MT18 - NT12	18	3/4



Reducer

R

Connect metric tube to fractional C-Lok port

Part Number	Tube O.D.	Tube O.D.	
		inch	mm
R - S2 - FT2	2	1/8	3.17
R - S3 - FT2	3	1/8	3.17
R - S3 - FT4	3	1/4	6.35
R - S4 - FT4	4	1/4	6.35
R - S6 - FT2	6	1/8	3.18
R - S6 - FT4	6	1/4	6.35
R - S6 - FT4	6	3/8	9.52
R - S6 - FT8	6	1/2	12.70
R - S8 - FT6	8	3/8	9.52
R - S8 - FT8	8	1/2	12.70
R - S10 - FT6	10	3/8	9.52
R - S10 - FT8	10	1/2	12.70
R - S12 - FT8	12	1/2	12.70
R - S12 - FT12	12	3/4	19.05
R - S18 - FT12	18	3/4	19.05
R - S18 - FT16	18	1	25.40
R - S25 - FT16	25	1	25.40

C-LOK

Instrument Valve Co., Ltd.

C-LOK the high quality instrumentation valves & fittings specialized production manufacture

Reducer

R

Connect metric tube to metric C-LOK port



Part Number	Tube O.D.	Tube O.D.
R-SM4-MT6	4	6
R-SM6-MT3	6	3
R-SM6-MT8	6	8
R-SM6-MT10	6	10
R-SM6-MT12	6	12
R-SM8-MT6	8	6
R-SM8-MT10	8	10
R-SM8-MT12	8	12
R-SM10-MT6	10	6
R-SM10-MT12	10	12
R-SM10-MT15	10	15
R-SM10-MT18	10	18
R-SM12-MT6	12	6
R-SM12-MT10	12	10
R-SM12-MT16	12	16
R-SM12-MT18	12	18
R-SM12-MT20	12	20
R-SM12-MT22	12	22
R-SM12-MT25	12	25
R-SM16-MT12	16	12
R-SM18-MT12	18	12
R-SM18-MT16	18	16
R-SM18-MT20	18	20
R-SM18-MT22	18	22
R-SM18-MT25	18	25
R-SM20-MT16	20	16
R-SM20-MT18	20	18
R-SM20-MT22	20	22
R-SM20-MT25	20	25
R-SM22-MT18	22	18
R-SM22-MT20	22	20
R-SM22-MT25	22	25
R-SM25-MT18	25	18
R-SM25-MT20	25	20



C-LOK

Instrument Valve Co., Ltd.

C-LOK the high quality instrumentation valves & fittings specialized production manufacture

Port Connector

P

Connect two fractional C-LOK port



Part Number	Tube O.D.	
	inch	mm
P - S2	1/8	3.17
P - S4	1/4	6.35
P - S6	3/8	9.52
P - S8	1/2	12.70
P - S12	3/4	19.05
P - S16	1	25.40

Port Connector

P

Connect two metric C-LOK port



Part Number	Tube O.D. mm
P - SM4	4
P - SM6	6
P - SM8	8
P - SM10	10
P - SM12	12
P - SM15	15
P - SM16	16
P - SM18	18
P - SM20	20
P - SM22	22
P - SM25	25



C-LOK

Instrument Valve Co., Ltd.

C-LOK the high quality instrumentation valves & fittings specialized production manufacture



Nut

NUT

Fractional

Part Number	Tube O.D.	
	inch	mm
NUT - S1	1/16	1.58
NUT - S2	1/8	3.17
NUT - S4	1/4	6.35
NUT - S6	3/8	9.52
NUT - S8	1/2	12.70
NUT - S12	3/4	19.05
NUT - S16	1	25.40

Nut

NUT

Metric

Part Number	Tube O.D.
NUT - SM4	4
NUT - SM6	6
NUT - SM8	8
NUT - SM10	10
NUT - SM12	12
NUT - SM15	15
NUT - SM16	16
NUT - SM18	18
NUT - SM20	20
NUT - SM22	22
NUT - SM25	25



C-LOK

Instrument Valve Co., Ltd.

C-LOK the high quality instrumentation valves & fittings specialized production manufacture



Front Ferrule

FF

Fractional

Part Number	Tube O.D.	
	inch	mm
FF - S1	1/16	1.58
FF - S2	1/8	3.17
FF - S4	1/4	6.35
FF - S6	3/8	9.52
FF - S8	1/2	12.70
FF - S12	3/4	19.05
FF - S16	1	25.40

Front Ferrule

FF

Metric



Part Number	Tube O.D.
FF - SM4	4
FF - SM6	6
FF - SM8	8
FF - SM10	10
FF - SM12	12
FF - SM15	15
FF - SM16	16
FF - SM18	18
FF - SM20	20
FF - SM22	22
FF - SM25	25



C-LOK

Instrument Valve Co., Ltd.

C-LOK the high quality instrumentation valves & fittings specialized production manufacture



Back Ferrule

BF

Fractional

Part Number	Tube O.D.	
	inch	mm
BF - S1	1/16	1.58
BF - S2	1/8	3.17
BF - S4	1/4	6.35
BF - S6	3/8	9.52
BF - S8	1/2	12.70
BF - S12	3/4	19.05
BF - S16	1	25.40

Back Ferrule

BF

Metric

Part Number	Tube O.D.
BF - SM4	4
BF - SM6	6
BF - SM8	8
BF - SM10	10
BF - SM12	12
BF - SM15	15
BF - SM16	16
BF - SM18	18
BF - SM20	20
BF - SM22	22
BF - SM25	25



“ PIPE
FITTING



C-LOK the high quality
instrumentation valves
& fittings specialized
production manufacture



Hex Plugs

PI

Male NPT Threads

P-NPT Size	Basic Ordering Number	Dimension, mm			
		L	F	B	D
1/16	-PI-NT1	7.6	4.0	7.4	7.4
1/8	-PI-NT2	10.4	4.8	7.4	9.4
1/4	-PI-NT4	15.5	6.4	12.4	12.1
3/8	-PI-NT6	15.0	7.9	11.9	15.7
1/2	-PI-NT8	19.3	9.5	16.2	19.3
3/4	-PI-NT12	19.8	14.3	16.7	25.7
1	-PI-NT16	20.8	15.9	17.7	31.8



Pipe Caps

PC

Female NPT Threads

P-NPT Size	Basic Ordering Number	Dimension, mm			Working Pressure psig (bar)	
		L	F	B	316 SS, Steel	Brass
1/16	-PC-NT1	12.7	11.1	9.9	6700 (460)	3300 (227)
1/8	-PC-NT2	19.1	14.3	10.4	6500 (447)	3200 (220)
1/4	-PC-NT4	23.1	19.1	15.0	6600 (454)	3300 (277)
3/8	-PC-NT6	26.2	22.2	15.0	5300 (365)	2600 (179)
1/2	-PC-NT8	34.0	27.0	19.8	4900 (337)	2400 (165)
3/4	-PC-NT12	36.6	33.3	20.6	4600 (316)	2300 (158)
1	-PC-NT16	41.1	41.3	25.4	4400 (303)	2200 (151)

C-LOK

Instrument Valve Co., Ltd.

C-LOK the high quality instrumentation valves & fittings specialized production manufacture



Hex Nipples

PHN

Male NPT Threads

P-NPT Size	Px-NPT Size	Basic Ordering Number	Dimension, mm					Working Pressure psig (bar)	
			L	F	B	Bx	E	316 SS, Steel	Brass
1/16	1/16	PHN-NT1	25.6	7.9	9.7	9.7	3.0	11000 (757)	5500 (378)
1/8	1/16	PHN-NT2-NT1	25.6	11.1	9.7	9.7	3.0	11000 (757)	5500 (378)
1/8	1/8	PHN-NT2	25.6	11.1	9.7	9.7	4.8	10000 (689)	5000 (344)
1/4	1/16	PHN-NT4-NT1	31.0	14.3	14.2	9.7	3.0	11000 (757)	5500 (378)
1/4	1/8	PHN-NT4-NT2	31.0	14.3	14.2	9.7	4.8	10000 (689)	5000 (344)
1/4	1/4	PHN-NT4	35.6	14.3	14.2	14.2	7.1	8000 (551)	4000 (275)
3/8	1/16	PHN-NT6-NT1	31.8	17.5	14.2	9.7	3.0	11000 (757)	5500 (378)
3/8	1/8	PHN-NT6-NT2	31.8	17.5	14.2	9.7	4.8	10000 (689)	5000 (344)
3/8	1/4	PHN-NT6-NT4	36.3	17.5	14.2	14.2	7.1	8000 (551)	4000 (275)
3/8	3/8	PHN-NT6	36.3	17.5	14.2	14.2	9.7	7800 (537)	3900 (268)
1/2	1/8	PHN-NT8-NT2	37.3	22.2	19.1	9.7	4.8	7700 (530)	3800 (261)
1/2	1/4	PHN-NT8-NT4	41.9	22.2	19.1	14.2	7.1	8000 (551)	4000 (275)
1/2	3/8	PHN-NT8-NT6	41.9	22.2	19.1	14.2	9.7	7800 (537)	3900 (268)
1/2	1/2	PHN-NT8	46.7	22.2	19.1	19.1	11.9	7700 (530)	3800 (261)
3/4	1/8	PHN-NT12-NT2	40.4	27.0	19.1	9.7	4.8	10000 (689)	5000 (344)
3/4	1/4	PHN-NT12-NT4	41.9	27.0	19.1	14.2	7.1	8000 (551)	4000 (275)
3/4	3/8	PHN-NT12-NT6	45.2	27.0	19.1	14.2	9.7	7800 (537)	3900 (268)
3/4	1/2	PHN-NT12-NT8	46.7	27.0	19.1	19.1	11.9	7700 (530)	3800 (261)
3/4	3/4	PHN-NT12	46.7	27.0	19.1	19.1	15.7	7300 (502)	3600 (248)
1	1/8	PHN-NT16-NT2	45.2	34.9	23.9	9.7	4.8	10000 (689)	5000 (344)
1	1/4	PHN-NT16-NT4	49.3	34.9	23.9	14.2	7.1	5300 (365)	2600 (179)
1	3/8	PHN-NT16-NT6	50.0	34.9	23.9	14.2	9.7	7800 (537)	3900 (268)
1	1/2	PHN-NT16-NT8	54.1	34.9	23.9	19.1	11.9	7700 (530)	3800 (261)
1	3/4	PHN-NT16-NT12	54.1	34.9	23.9	19.1	15.7	7300 (502)	3600 (248)
1	1	PHN-NT16	58.9	34.9	23.9	23.9	22.4	5300 (365)	2600 (179)
1 1/4	1	PHN-NT20-NT16	62.2	44.5	23.9	23.9	22.4	5300 (365)	2600 (179)
1 1/4	1 1/4	PHN-NT20	62.9	44.5	23.9	23.9	28.6	6000 (418)	3000 (200)
1 1/2	1 1/2	PHN-NT24	66.3	50.8	26.2	26.2	34.0	5000 (344)	2500 (172)
2	2	PHN-NT32	77.7	63.9	26.2	26.2	45.0	3500 (268)	1900 (130)





Hex Long Nipples

PLN

Male NPT Threads

P-NPT Size	Basic Ordering Number	Dimension, mm			Working Pressure psig (bar)	
		L	F	E	316 SS, Steel	Brass
1/8	-PLN-NT2-38.1	38.1	11.1	4.8	10000 (689)	5000 (344)
1/8	-PLN-NT2-50.8	50.8	11.1	4.8	10000 (689)	5000 (344)
1/8	-PLN-NT2-63.5	63.5	11.1	4.8	10000 (689)	5000 (344)
1/8	-PLN-NT2-76.2	76.2	11.1	4.8	10000 (689)	5000 (344)
1/4	-PLN-NT4-38.1	38.1	14.3	7.1	8000 (551)	4000 (275)
1/4	-PLN-NT4-50.8	50.8	14.3	7.1	8000 (551)	4000 (275)
1/4	-PLN-NT4-63.5	63.5	14.3	7.1	8000 (551)	4000 (275)
1/4	-PLN-NT4-76.2	76.2	14.3	7.1	8000 (551)	4000 (275)
1/4	-PLN-NT4-101.6	101.6	14.3	7.1	8000 (551)	4000 (275)
3/8	-PLN-NT6-38.1	38.1	17.5	9.7	7800 (537)	3900 (268)
3/8	-PLN-NT6-50.8	50.8	17.5	9.7	7800 (537)	3900 (268)
3/8	-PLN-NT6-63.5	63.5	17.5	9.7	7800 (537)	3900 (268)
3/8	-PLN-NT6-76.2	76.2	17.5	9.7	7800 (537)	3900 (268)
3/8	-PLN-NT6-101.6	101.6	17.5	9.7	7800 (537)	3900 (268)
1/2	-PLN-NT8-50.8	50.8	22.2	11.9	7700 (530)	3800 (261)
1/2	-PLN-NT8-76.2	76.2	22.2	11.9	7700 (530)	3800 (261)
1/2	-PLN-NT8-101.6	101.6	22.2	11.9	7700 (530)	3800 (261)
1/2	-PLN-NT8-152.4	152.4	22.2	11.9	7700 (530)	3800 (261)
3/4	-PLN-NT12-50.8	50.8	27.0	15.7	7300 (502)	3600 (248)
3/4	-PLN-NT12-76.2	76.2	27.0	15.7	7300 (502)	3600 (248)
3/4	-PLN-NT12-101.6	101.6	27.0	15.7	7300 (502)	3600 (248)
1	-PLN-NT16-76.2	76.2	34.9	22.4	5300 (365)	2600 (179)
1	-PLN-NT16-101.6	101.6	34.9	22.4	5300 (365)	2600 (179)



Reducing Bushings

PRB

Male NPT Threads

Female NPT Threads

P-NPT Size	Px-NPT Size	Basic Ordering Number	Dimension, mm					Working Pressure psig (bar)	
			L	F	B	Bx	E	316 SS, Steel	Brass
1/8	1/16	-PRB-NT2-NT1	26.2	11.1	9.7	9.9	4.8	6500 (447)	3200 (220)
1/4	1/16	-PRB-NT4-NT1	21.8	14.3	14.2	9.9	4.8	8000 (551)	4000 (275)
1/4	1/8	-PRB-NT4-NT2	26.9	14.3	14.2	10.4	7.1	6500 (447)	3300 (227)
3/8	1/16	-PRB-NT6-NT1	21.8	17.5	14.2	9.9	4.8	13300 (971)	6600 (454)
3/8	1/8	-PRB-NT6-NT2	21.8	17.5	14.2	10.4	8.6	9200 (633)	4700 (323)
3/8	1/4	-PRB-NT6-NT4	30.2	19.1	14.2	15.0	9.6	6600 (454)	3300 (227)
1/2	1/8	-PRB-NT8-NT2	27.4	22.2	19.1	10.4	8.6	12200 (840)	6200 (427)
1/2	1/4	-PRB-NT8-NT4	27.4	22.2	19.1	15.0	11.4	8300 (571)	4400 (303)
1/2	3/8	-PRB-NT8-NT6	35.8	22.2	19.1	15.0	11.9	5300 (365)	2600 (179)
3/4	1/8	-PRB-NT12-NT2	27.4	27.0	19.1	10.4	7.1	20000(1378)	10000(689)
3/4	1/4	-PRB-NT12-NT4	27.4	27.0	19.1	15.0	11.4	12000 (826)	6000 (410)
3/4	3/8	-PRB-NT12-NT6	27.4	27.0	19.1	15.0	15.0	8200 (564)	4300 (296)
3/4	1/2	-PRB-NT12-NT8	41.4	27.0	19.1	19.8	15.7	4900 (337)	2400 (165)
1	1/8	-PRB-NT16-NT2	34.5	34.9	23.9	10.4	7.1	20000(1378)	10000(689)
1	1/4	-PRB-NT16-NT4	34.8	34.9	23.9	15.0	11.4	14500 (999)	7400 (509)
1	3/8	-PRB-NT16-NT6	34.8	34.9	23.9	15.0	15.0	11600 (799)	5900 (406)
1	1/2	-PRB-NT16-NT8	34.8	34.9	23.9	19.8	18.5	8600 (592)	4300 (296)
1	3/4	-PRB-NT16-NT12	47.0	34.9	23.9	20.6	22.4	5300 (365)	2600 (179)
1 1/4	3/4	-PRB-NT20-NT12	37.3	44.5	23.9	20.6	22.4	7800 (537)	3900 (268)
1 1/4	1	-PRB-NT20-NT16	37.3	44.5	23.9	25.4	22.4	3500 (241)	1750 (120)
1 1/2	1	-PRB-NT24-NT16	40.1	50.8	26.2	25.4	22.4	6600 (454)	3300 (227)
1 1/2	1 1/4	-PRB-NT24-NT20	56.0	54.0	26.2	25.4	34.0	5000 (344)	2500 (172)

C-LOK

Instrument Valve Co., Ltd.

C-LOK the high quality instrumentation valves & fittings specialized production manufacture



Female Tees

PT

Female NPT Threads

P-NPT Size	Basic Ordering Number	Dimension, mm				Working Pressure psig (bar)	
		L	F	E	B	316 SS, Steel	Brass
1/16	-PT-NT1	21.8	11.1	4.8	9.9	6700 (460)	3300 (227)
1/8	-PT-NT2	26.4	12.7	8.6	10.4	6200 (427)	3100 (213)
1/4	-PT-NT4	29.7	17.5	11.4	15.0	7200 (496)	3600 (248)
3/8	-PT-NT6	36.1	20.6	15.0	15.0	5600 (385)	2800 (192)
1/2	-PT-NT8	39.6	25.4	18.5	19.8	5600 (385)	2800 (192)
3/4	-PT-NT12	48.8	31.8	23.9	20.6	5100 (351)	2500 (172)
1	-PT-NT16	48.5	42.9	29.7	25.4	6400 (440)	3200 (220)
1 1/4	-PT-NT20	59.8	50.8	37.2	25.4	3100 (213)	1600 (110)
1 1/2	-PT-NT24	65.0	63.5	43.3	27.7	5100 (351)	2500 (172)



Male Tees

PMT

Male NPT Threads

P-NPT Size	Basic Ordering Number	Dimension, mm				Working Pressure psig (bar)	
		L	F	B	E	316 SS, Steel	Brass
1/16	-PMT-NT1	18.3	9.5	9.7	3.0	11000 (757)	5500 (378)
1/8	-PMT-NT2	22.4	11.1	9.7	4.8	10000 (689)	5000 (344)
1/4	-PMT-NT4	26.7	12.7	14.2	7.1	8000 (551)	4000 (275)
3/8	-PMT-NT6	29.7	17.5	14.2	9.6	7800 (537)	3900 (268)
1/2	-PMT-NT8	36.8	20.6	19.1	11.9	7700 (530)	3800 (261)
3/4	-PMT-NT12	42.4	27.0	19.1	15.7	7300 (502)	3600 (248)
1	-PMT-NT16	49.3	34.9	23.9	22.4	5300 (365)	2600 (179)
1 1/4	-PMT-NT20	56.4	42.9	23.9	27.7	6000 (410)	3000 (200)
1 1/2	-PMT-NT24	67.1	47.6	26.2	34.0	5000 (344)	2500 (172)





Adapters

PA

Female NPT Threads

Male NPT Threads

P-NPT Size	Px-NPT Size	Basic Ordering Number	Dimension, mm					Working Pressure psig (bar)	
			L	F	B	Bx	E	316 SS, Steel	Brass
1/16	1/16	-PA-NT2-NT1	27.7	14.3	10.4	9.7	3.0	6500 (447)	3200 (220)
1/8	1/8	-PA-NT2	27.9	14.3	10.4	9.7	4.8	6500 (447)	3200 (220)
1/4	1/16	-PA-NT4-NT1	30.5	19.1	15.0	9.7	3.0	6600 (454)	3300 (227)
1/4	1/8	-PA-NT4-NT2	32.0	19.1	15.0	9.7	4.8	6600 (454)	3300 (227)
1/4	1/4	-PA-NT4	35.6	19.1	15.0	14.2	7.1	6600 (454)	3300 (227)
3/8	1/16	-PA-NT6-NT1	31.8	22.2	15.0	9.7	3.0	5300 (365)	2600 (179)
3/8	1/8	-PA-NT6-NT2	33.8	22.2	15.0	9.7	4.8	5300 (365)	2600 (179)
3/8	1/4	-PA-NT6-NT4	38.1	22.2	15.0	14.2	7.1	5300 (365)	2600 (179)
3/8	3/8	-PA-NT6	38.4	22.2	15.0	14.2	9.6	5300 (365)	2600 (179)
1/2	1/8	-PA-NT8-NT2	40.1	27.0	19.8	9.7	4.8	4900 (337)	2400 (165)
1/2	1/4	-PA-NT8-NT4	44.7	27.0	19.8	14.2	7.1	4900 (337)	2400 (165)
1/2	3/8	-PA-NT8-NT6	44.4	27.0	19.8	14.2	9.6	4900 (337)	2400 (165)
1/2	1/2	-PA-NT8	49.3	27.0	19.8	19.1	11.9	4900 (337)	2400 (165)
3/4	1/8	-PA-NT12-NT2	39.6	33.3	20.6	9.7	4.8	4600 (316)	2300 (158)
3/4	1/4	-PA-NT12-NT4	47.0	33.3	20.6	14.2	7.1	4600 (316)	2300 (158)
3/4	3/8	-PA-NT12-NT6	46.2	33.3	20.6	14.2	9.6	4600 (316)	2300 (158)
3/4	1/2	-PA-NT12-NT8	51.3	33.3	20.6	19.1	11.9	4600 (316)	2300 (158)
3/4	3/4	-PA-NT12	51.3	33.3	20.6	19.1	15.7	4600 (316)	2300 (158)
1	1/8	-PA-NT16-NT2	46.0	41.3	25.4	9.7	4.8	4400 (303)	2200 (151)
1	1/4	-PA-NT16-NT4	49.8	41.3	25.4	14.2	7.1	4400 (303)	2200 (151)
1	3/8	-PA-NT16-NT6	50.8	41.3	25.4	14.2	9.6	4400 (303)	2200 (151)
1	1/2	-PA-NT16-NT8	54.9	41.3	25.4	19.1	11.9	4400 (303)	2200 (151)
1	3/4	-PA-NT16-NT12	55.1	41.3	25.4	19.1	15.7	4400 (303)	2200 (151)
1	1	-PA-NT16	57.9	41.3	25.4	23.9	22.4	4400 (303)	2200 (151)
1 1/4	1	-PA-NT20-NT16	62.7	54.0	25.4	23.9	22.4	5000 (344)	2500 (172)

C-LOK

Instrument Valve Co., Ltd.

C-LOK the high quality instrumentation valves & fittings specialized production manufacture



Street Elbows

PSE

Female NPT Threads

Male NPT Threads

P-NPT Size	Px-NPT Size	Basic Ordering Number	Dimesiç mm						Working Pressure psig (bar)	
			L	F	B	E	Lx	Bx	316 SS, Steel	Brass
1/16	1/16	-PSE-NT1	21.8	11.1	9.9	3.0	22.4	9.7	9200 (633)	4600 (316)
1/16	1/8	-PSE-NT1-NT2	21.8	11.1	9.9	4.8	22.4	9.7	9200 (633)	4600 (316)
1/16	1/4	-PSE-NT1-NT4	22.4	14.3	9.9	4.8	27.7	14.2	8000 (551)	4000 (275)
1/16	3/8	-PSE-NT1-NT6	22.4	17.5	9.9	4.8	29.7	14.2	7800 (537)	3900 (268)
1/8	1/16	-PSE-NT2-NT1	26.4	12.7	10.4	3.0	22.1	9.7	6200 (426)	3100 (213)
1/8	1/8	-PSE-NT2	26.4	12.7	10.4	4.8	22.1	9.7	6200 (426)	3100 (213)
1/8	1/4	-PSE-NT2-NT4	22.4	14.3	10.4	7.1	27.7	14.2	6500 (447)	3200 (220)
1/8	3/8	-PSE-NT2-NT6	22.4	17.5	10.4	7.1	29.7	14.2	7800 (537)	3900 (268)
1/8	1/2	-PSE-NT2-NT8	24.1	20.6	10.4	7.1	36.8	19.1	7700 (530)	3800 (261)
1/8	3/4	-PSE-NT2-NT12	25.4	27.0	10.4	7.1	40.4	19.1	7300 (502)	3600 (248)
1/8	1	-PSE-NT2-NT16	26.4	34.9	10.4	7.1	50.0	23.9	5300 (365)	2600 (179)
1/4	1/8	-PSE-NT4-NT2	29.7	17.5	15.0	4.8	25.4	9.7	7200 (496)	3600 (248)
1/4	1/4	-PSE-NT4	29.7	17.5	15.0	7.1	29.7	14.2	7200 (496)	3600 (248)
1/4	3/8	-PSE-NT4-NT6	29.7	17.5	15.0	8.6	29.7	14.2	7200 (496)	3600 (248)
1/4	1/2	-PSE-NT4-NT8	25.4	20.6	15.0	8.6	36.8	19.1	7200 (496)	3600 (248)
1/4	3/4	-PSE-NT4-NT12	25.4	27.0	15.0	8.6	40.4	19.1	7300 (502)	3600 (248)
1/4	1	-PSE-NT4-NT16	41.4	34.9	15.0	8.6	50.0	23.9	5300 (365)	2600 (179)
3/8	1/4	-PSE-NT6-NT4	36.1	20.6	15.0	7.1	32.0	14.2	5600 (385)	2800 (192)
3/8	3/8	-PSE-NT6	36.1	20.6	15.0	9.6	32.0	14.2	5600 (385)	2800 (192)
3/8	1/2	-PSE-NT6-NT8	36.1	20.6	15.0	11.9	36.8	19.1	5600 (385)	2800 (192)
3/8	3/4	-PSE-NT6-NT12	31.2	27.0	15.0	11.9	40.4	19.1	7300 (502)	3600 (248)
3/8	1	-PSE-NT6-NT16	41.4	34.9	15.0	11.9	50.0	23.9	5300 (365)	2600 (179)
1/2	1/4	-PSE-NT8-NT4	39.6	25.4	19.8	7.1	35.1	14.2	5600 (385)	2800 (192)
1/2	3/8	-PSE-NT8-NT6	39.6	25.4	19.8	9.6	35.1	14.2	5600 (385)	2800 (192)
1/2	1/2	-PSE-NT8	39.6	25.4	19.8	11.9	39.6	19.1	5600 (385)	2800 (192)
1/2	3/4	-PSE-NT8-NT12	31.2	27.0	19.8	15.7	40.4	19.1	5600 (385)	2800 (192)
1/2	1	-PSE-NT8-NT16	41.4	34.9	19.8	15.7	50.0	23.9	5300 (365)	2600 (179)
3/4	3/4	-PSE-NT12	48.8	31.8	20.6	15.7	42.4	19.1	5100 (351)	2500 (172)
3/4	1	-PSE-NT12-NT16	41.4	34.9	20.6	22.4	50.0	23.9	5100 (351)	2500 (172)
1	1	-PSE-NT16	48.5	42.9	25.4	22.4	49.3	23.9	5300 (365)	2600 (179)
1 1/4	1 1/4	-PSE-NT20	60.5	50.8	25.4	31.8	60.5	23.9	3100 (213)	1600 (110)





Female Elbows

PE

Female NPT Threads

P-NPT Size	Px-NPT Size	Basic Ordering Number	Dimension, mm						Working Pressure psig (bar)	
			L	F	B	E	Lx	Bx	316 SS, Steel	Brass
1/16	1/16	-PE-NT1	21.8	11.1	9.9	4.8	21.8	9.9	6700 (460)	3300 (227)
1/8	1/16	-PE-NT2-NT1	26.4	12.7	10.4	4.8	26.4	9.9	6200 (427)	3100 (213)
1/8	1/8	-PE-NT2	26.4	12.7	10.4	7.1	26.4	10.4	6200 (427)	3100 (213)
1/4	1/8	-PE-NT4-NT2	29.7	17.5	15.0	7.1	29.7	10.4	7200 (496)	3600 (248)
1/4	1/4	-PE-NT4	29.7	17.5	15.0	10.4	29.7	15.0	7200 (496)	3600 (248)
3/8	3/8	-PE-NT6	36.1	20.6	15.0	12.7	36.1	15.0	5600 (385)	2800 (192)
1/2	1/2	-PE-NT8	39.6	25.4	19.8	17.1	39.6	19.8	5600 (385)	2800 (192)
3/4	3/4	-PE-NT12	48.8	31.8	20.6	22.4	48.8	20.6	5100 (351)	2500 (172)
1	1	-PE-NT16	48.5	42.9	25.4	28.1	48.5	25.4	6400 (440)	3200 (220)
1 1/4	1 1/4	-PE-NT20	59.8	50.8	25.4	27.7	59.8	25.4	3100 (213)	1600 (110)
1 1/2	1 1/2	-PE-NT24	65.0	63.5	27.7	34.0	65.0	27.7	5100 (351)	2500 (172)



Male Elbows

PME

Male NPT Threads

P-NPT Size	Basic Ordering Number	Dimension, mm				Working Pressure psig (bar)	
		L	F	B	E	316 SS, Steel	Brass
1/16	-PME-NT1	18.3	9.5	9.7	3.0	11000 (757)	5500 (378)
1/8	-PME-NT2	22.4	11.1	9.7	4.8	10000 (689)	5000 (344)
1/4	-PME-NT4	26.7	12.7	14.2	7.1	8000 (551)	4000 (275)
3/8	-PME-NT6	29.7	17.5	14.2	9.6	7800 (537)	3900 (268)
1/2	-PME-NT8	36.8	20.6	19.1	11.9	7700 (530)	3800 (261)
3/4	-PME-NT12	40.4	27.0	19.1	15.7	7300 (502)	3600 (248)
1	-PME-NT16	50.0	34.9	23.9	22.4	5300 (365)	2600 (179)

C-LOK

Instrument Valve Co., Ltd.

C-LOK the high quality instrumentation valves & fittings specialized production manufacture

Hex Couplings

PCG



Female NPT Threads

P-NPT Size	Px-NPT Size	Basic Ordering Number	Dimension, mm			Working Pressure psig (bar)	
			L	F	E	316 SS, Steel	Brass
1/16	1/16	-PCG-NT1	19.8	11.1	4.8	6700 (460)	3300 (227)
1/8	1/8	-PCG-NT2	20.6	14.3	8.6	6500 (447)	3200 (220)
1/4	1/8	-PCG-NT4-NT2	31.0	19.1	8.6	6600 (454)	3300 (227)
1/4	1/4	-PCG-NT4	30.2	19.1	11.4	6600 (454)	3300 (227)
3/8	1/4	-PCG-NT6-NT4	35.1	22.2	11.4	5300 (365)	2600 (179)
3/8	3/8	-PCG-NT6	33.3	22.2	15.0	5300 (365)	2600 (179)
1/2	1/8	-PCG-NT8-NT2	39.6	27.0	8.6	4900 (337)	2400 (165)
1/2	1/4	-PCG-NT8-NT4	44.4	27.0	11.4	4900 (337)	2400 (165)
1/2	3/8	-PCG-NT8-NT6	45.2	27.0	15.0	4900 (337)	2400 (165)
1/2	1/2	-PCG-NT8	39.6	27.0	18.5	4900 (337)	2400 (165)
3/4	1/4	-PCG-NT12-NT4	46.0	33.3	11.4	4600 (316)	2300 (158)
3/4	1/2	-PCG-NT12-NT6	52.3	33.3	18.5	4600 (316)	2300 (158)
3/4	3/4	-PCG-NT12	41.1	33.3	23.9	4600 (316)	2300 (158)
1	1/2	-PCG-NT16-NT6	55.6	41.3	18.5	4400 (303)	2200 (151)
1	3/4	-PCG-NT16-NT12	57.2	41.3	23.9	4400 (303)	2200 (151)
1	1	-PCG-NT16	50.8	41.3	29.7	4400 (303)	2200 (151)

“NEEDLE VALVE

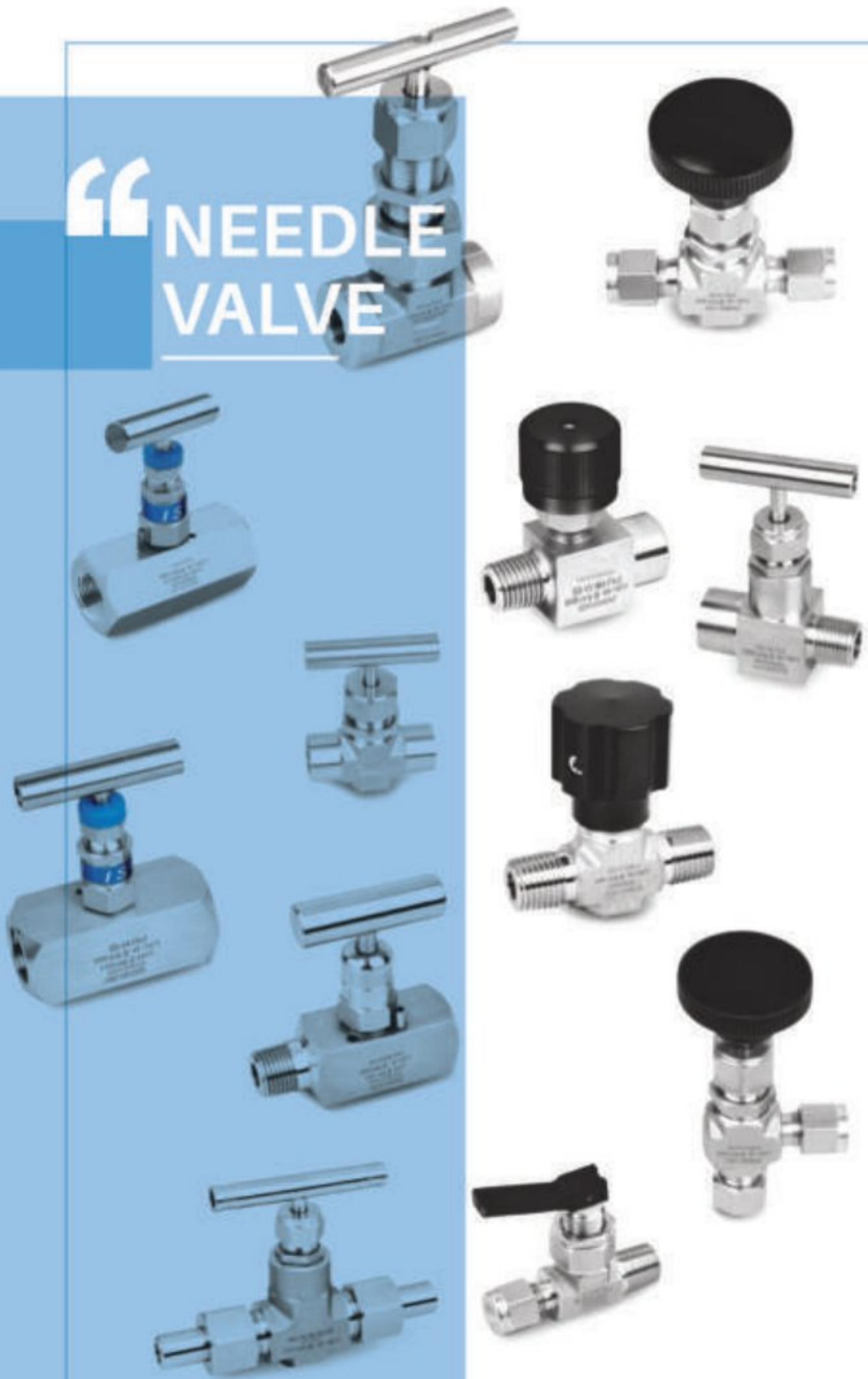

C-LOK the high quality instrumentation valves & fittings specialized production manufacture

C-LOK

Instrument Valve Co., Ltd.

C-LOK the high quality instrumentation valves & fittings specialized production manufacture

General Purpose Needle Valve

V1 Series

Features

- Working pressure:
- Stainless steel: up to 5000 psig (345 bar)
Steel: up to 3000 psig (207 bar)
Brass: up to 3000 psig (207 bar)
- Working temperature:
- PTFE: -65°F to 450°F (-54°C to 232°C)
- PEEK: -65°F to 600°F (-54°C to 315°C)
- Panel mountable
- Packing nut permits stem packing adjustment
- Live-loaded packing system
- Compact design



Technical Data

Temperature		Valve body material			
		316 SS	Carbon Steel	Alloy 400	Brass
°F	°C	Working pressure, psig (bar)			
-65~-20	-53~-28	5000(344)	—	3000(207)	3000(207)
-20~100	-28~37	5000(344)	3000(207)	3000(207)	3000(207)
200	93	4295(295)	2730(188)	2640(181)	2350(162)
250	121	4085(281)	2695(185)	2555(176)	2200(151)
300	148	3875(266)	2660(183)	2470(170)	2050(141)
350	176	3715(255)	2615(180)	2430(167)	1470(101)
400	204	3560(245)		2390(164)	390(27)
450	232	3435(236)		2380(163)	
500	260	3310(228)		2375(163)	
600	315	3130(215)			

Flow Data at 100°F (37°C)

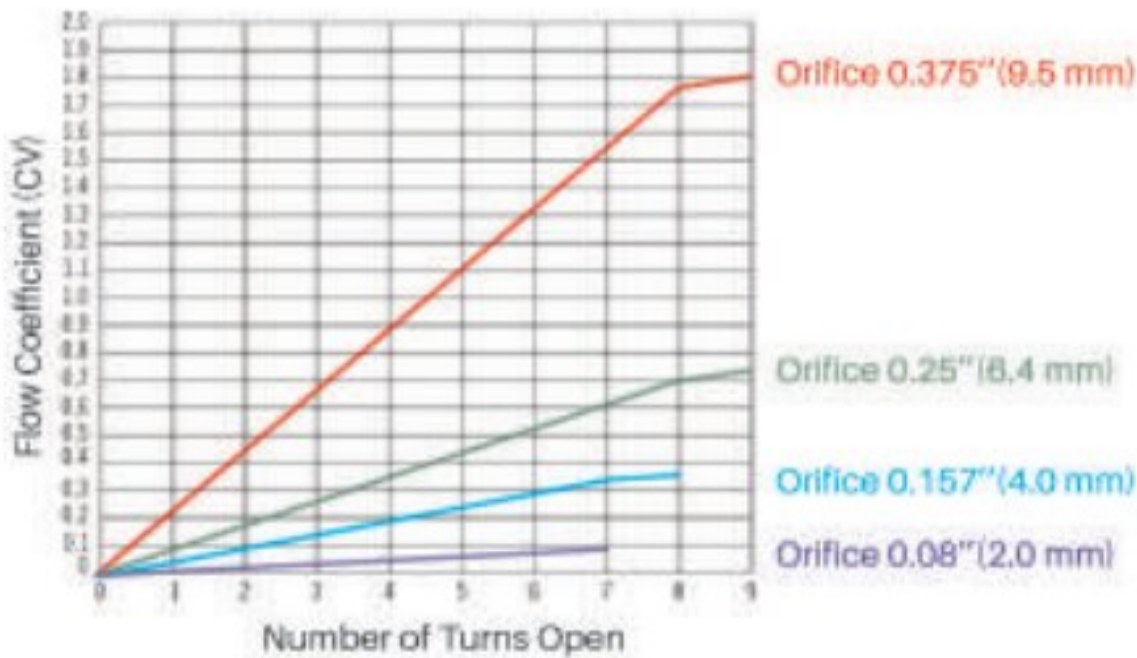

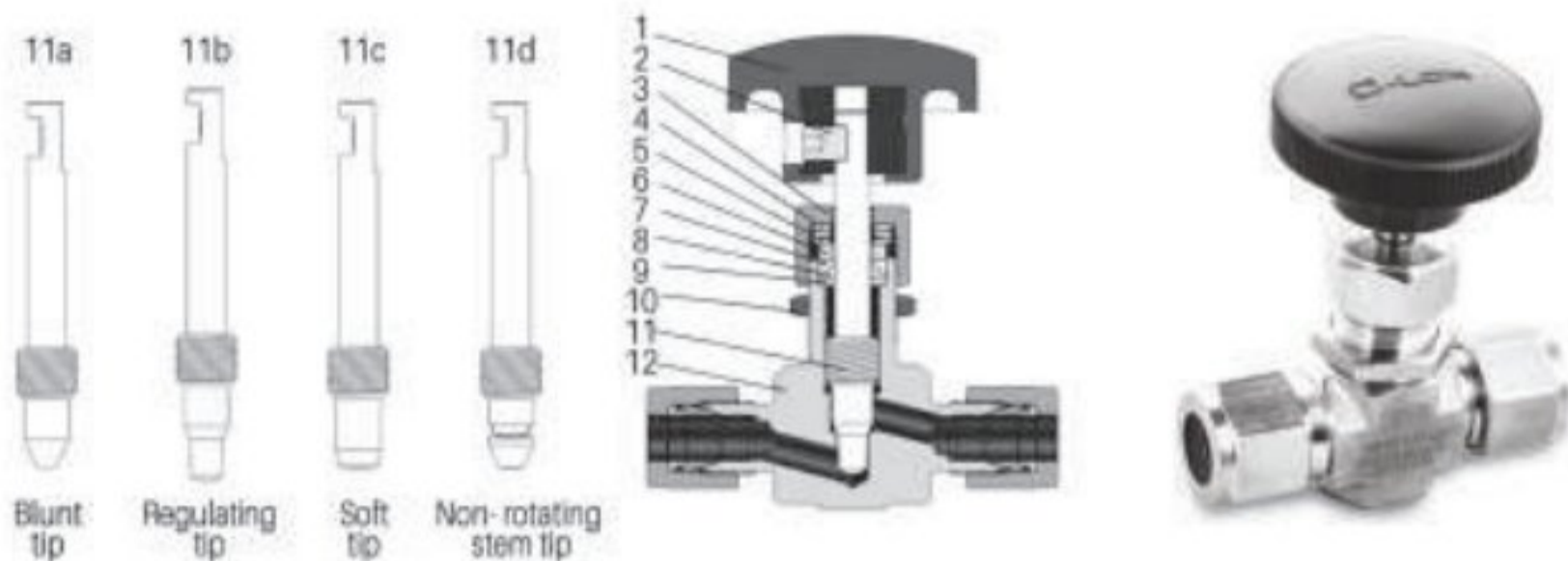

General Purpose Needle Valve

V1 Series

Materials of Construction

Item	Part	Valve Body Materials			
		316 SS	Brass	Steel	Alloy 400
1	Handle	Anodized aluminum/Stainless steel/Black knob			
2	Set screw	Nickel cadmium-plated steel			
3	Packing nut	316 SS/A276	Brass 360/B16	12L14/A108	Alloy R-405/B164
4	Gland	304 SS/A276			
5	Packing springs	S17700/A693			
6	Packing gland	304 SS/A276			
7	Upper packing	PTFE / PCTFE / PEEK			
8	Lower packing				
9	Lower gland	316 SS/A276		Alloy 400/B127	
10	Panel nut	316 SS/B783			
11	Stem	Chrome-plated 316 SS/A276			Alloy R-405/B164
12	Body	316 SS/A182	Brass 377/B283	Chrome-plated 11L17/A108	Alloy 400/B564
	Lubricant	Molybdenum disulfide-based and silicone-based			

General Purpose Needle Valve

V1 Series

Table of Dimensions

Basic Model Number	End Connection		Orifice in.(mm)	Cv
	Inlet	Outlet		
-V1-F2-2	1/8 Female NPT	1/8 Female NPT	0.08(2.0)	0.09
-V1-S2-2	1/8" OD	1/8" OD		
-V1-SM3-2	3mm OD	3mm OD		
-V1-F2-4	1/8 Female NPT	1/8 Female NPT	0.157(4.0)	0.35
-V1-M2-4	1/8 Male NPT	1/8 Male NPT		
-V1-M4-4	1/4 Male NPT	1/4 Male NPT		
-V1-S4-4	1/4" OD	1/4" OD		
-V1-SM6-4	6mm OD	6mm OD		
-V1-SM8-4	8mm OD	8mm OD		
-V1-F4-6	1/4 Female NPT	1/4 Female NPT	0.25(6.4)	0.73
-V1-F6-6	3/8 Female NPT	3/8 Female NPT		
-V1-M6-6	3/8 Male NPT	3/8 Male NPT		
-V1-M8-6	1/2 Male NPT	1/2 Male NPT		
-V1-S6-6	3/8" OD	3/8" OD		
-V1-S8-6	1/2" OD	1/2" OD		
-V1-SM10-6	10mm OD	10mm OD		
-V1-SM12-6	12mm OD	12mm OD		
-V1-SM14-6	14mm OD	14mm OD		
-V1-MM20-6	M20 x1.5 Male ISO	M20 x1.5 Male ISO		
-V1-F8-10	1/2 Female NPT	1/2 Female NPT	0.375(9.5)	1.80
-V1-F12-10	3/4 Female NPT	3/4 Female NPT		
-V1-M12-10	3/4 Male NPT	3/4 Male NPT		
-V1-S8-10	1/2" OD	1/2" OD		
-V1-S12-10	3/4" OD	3/4" OD		
-V1-SM14-10	14mm OD	14mm OD		

C-LOK

Instrument Valve Co., Ltd.

C-LOK the high quality instrumentation valves & fittings specialized production manufacture

Bar Stock Needle Valve

V4 Series



Features

- pressure up to 6000 psig (414 bar) for standard series
- pressure up to 10000 psig (689 bar) for high pressure series
- Temperature from -65°F to 450°F (-54°C to 232°C) with PTFE packing
- Temperature from -65°F to 1200°F (-54°C to 649°C) with Grafoil packing
- Non-rotating stem tip
- Packing below stem thread isolates the thread lubricants from the media
- Body to bonnet seal with metal to metal constant compression, isolates bonnet thread from the media
- Back seating design protects the packing in fully open position
- Panel mountable
- 100% factory tested

Flow Data at 100°F (37°C)

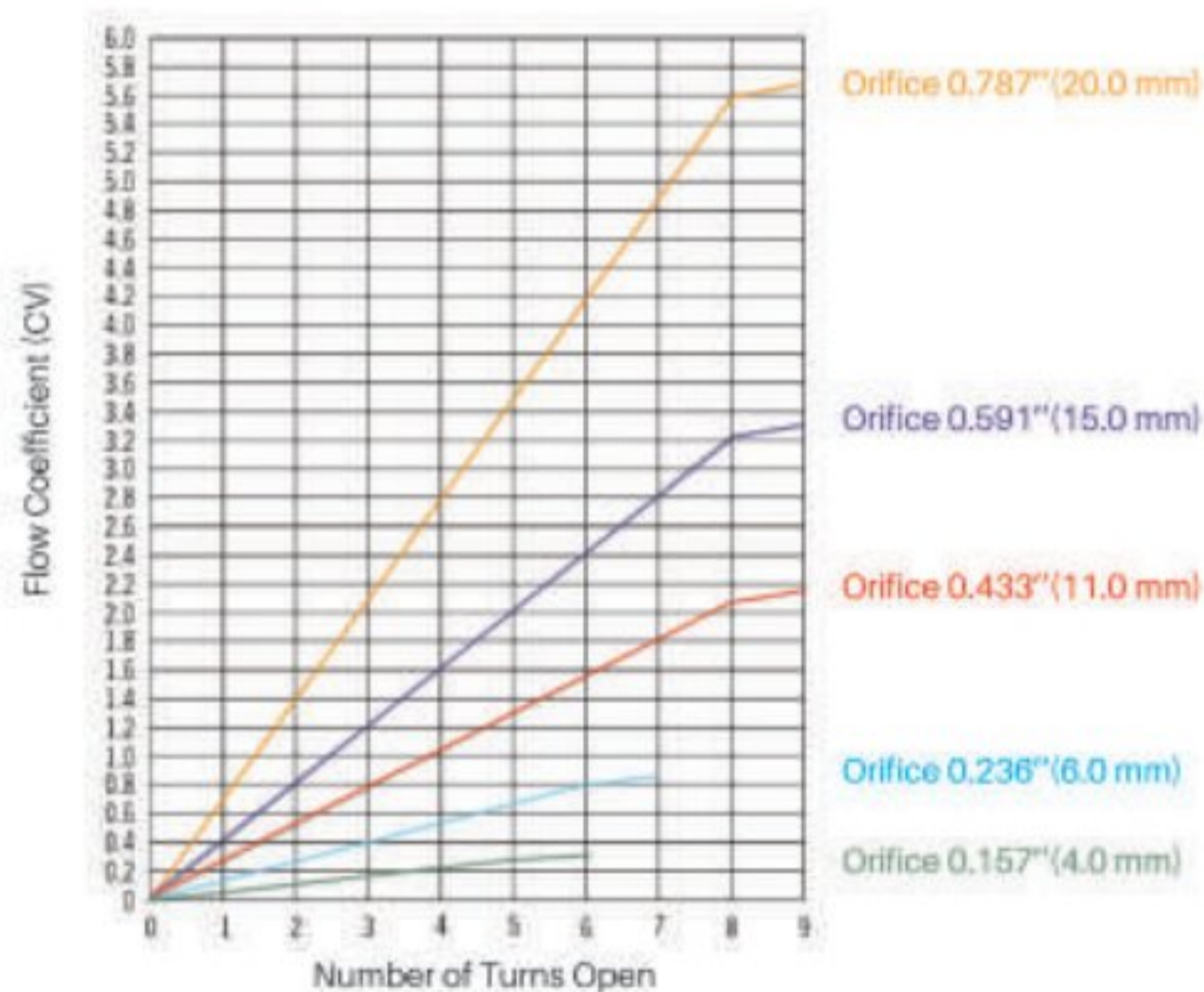

Bar Stock Needle Valve

V4 Series

Technical data

Standard pressure series(V4)

Temperature		Valve body material				
		316 SS	Alloy 400	Alloy C-276	Titanium	Brass
°F	°C	Working pressure, psig (bar)				
-65~100	-54~38	6000(414)	5000(344)	6000(414)	3570(245)	3000(207)
200	93	5160(356)	4400(303)	6000(414)	3110(214)	2350(162)
250	121	4910(338)	4260(293)	6000(414)	2840(195)	2200(151)
300	148	4660(321)	4120(283)	6000(414)	2570(177)	2050(141)
350	176	4470(307)	4050(279)	5975(411)	2385(164)	1470(101)
400	204	4280(295)	3980(274)	5880(405)	2200(151)	390(27)
450	232	4130(285)	3970(273)	5710(393)	2055(141)	
500	260	3980(274)	3960(272)	5540(381)	1885(129)	
600	315	3760(259)		5040(347)	1625(111)	
650	343	3690(254)		4905(337)		
700	371	3600(248)		4730(325)		
750	399	3510(242)		4430(305)		
800	426	3460(238)		4230(291)		
850	454	3380(232)		4060(279)		
900	482	3280(225)		3745(258)		
950	510	3220(221)		3220(221)		
1000	538	3030(208)		3030(208)		
1050	566	3000(207)		3000(207)		
1100	593	2685(184)		2685(184)		
1150	621	2285(157)		2285(157)		
1200	649	1715(118)		1545(106)		

Bar Stock Needle Valve

V4 Series

Technical data

High pressure series(V4H)

Temperature		Valve body material
		316 SS
°F	°C	Working pressure, psig (bar)
-65~100	-54~38	10000(689)
200	93	9290(640)
250	121	8840(609)
300	148	8390(578)
350	176	8045(554)
400	204	7705(530)
450	232	7435(512)
500	260	7165(493)
600	315	6770(466)
650	343	6660(458)
700	371	6480(446)
750	399	6335(436)
800	426	6230(429)
850	454	6085(419)
900	482	5905(406)
950	510	5795(399)
1000	538	5450(375)
1050	566	5400(372)
1100	593	4835(333)
1150	621	4115(283)
1200	649	3085(212)

C-LOK

Instrument Valve Co., Ltd.

C-LOK the high quality instrumentation valves & fittings specialized production manufacture

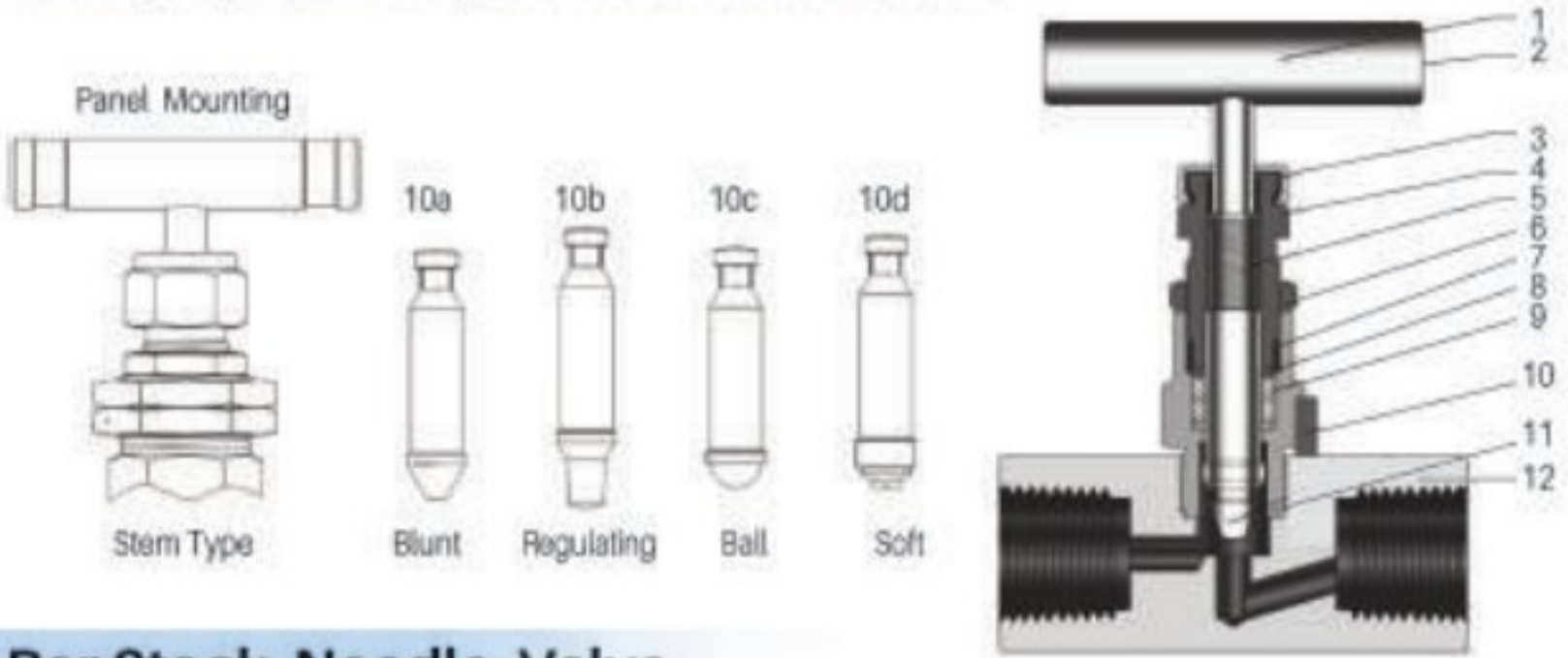

Bar Stock Needle Valve

V4 Series

Materials of Construction

Item	Part	Valve Body Materials				
		316 SS	Alloy 400	Alloy C-276	Titanium	Brass
1	Handle	Stainless steel / Anodized aluminum / Black knob				
2	Set screw	Nickel cadmium-plated steel				
3	Dust cap	Plastic				
4	Gland	316 SS/A276			Brass 360/B16	
5	Stem	Chrome-plated 316 SS/A276	Alloy R-405/B164	Alloy C-276/B574	TA8.8373.Titanium Gr 4/B348	Chrome-plated 316 SS/A276
6	Lock nut	316 SS/B783			Brass 360/B16	
7	Bonnet	316 SS/A479	Alloy R-405/B164	Alloy C-276/B574	Titanium Gr 4/B348	Brass 360/B16
8	Packing washer	316 SS/A276				
9	Packing	PTFE / PCTFE / PEEK / Graphit				
10	Lock pin	304 SS/A276				
11	Stem tip	Chrome-plated 316 SS/A276	Alloy R-405/B164	Alloy C-276/B574	TA8.8373.Titanium Gr 4/B348	Chrome-plated 316 SS/A276
		Different tips optional				
12	Body	316 SS/A479 316 SS/A182	Alloy 400/B164, B127, B564	Alloy C-276/B564	Titanium Gr 4/B348 or Titanium Gr 4/B381	Brass 360/B16
	Seat	Weld stellite optional				
Lubricant		Molybdenum disulfide-based				



Bar Stock Needle Valve

V4 Series

Table of Dimensions

Basic Model Number	End Connection		Orifice in.(mm)	Cv
	Inlet	Outlet		
-V4-F4-4	1/4 Female NPT	1/8 Female NPT	0.157(4.0)	0.35
-V4-M4-F4-4	1/4 Male NPT	1/4 Female NPT		
-V4-M4-4	1/4 Male NPT	1/4 Male NPT		
-V4-F6-4	3/8 Female NPT	3/8 Female NPT		
-V4-M6-F6-4	3/8 Male NPT	3/8 Female NPT		
-V4-M6-4	3/8 Male NPT	3/8 Male NPT		
-V4-F8-5	1/2 Female NPT	1/2 Female NPT	0.197(5.0)	0.73
-V4-M8-F8-5	1/2 Male NPT	1/2 Female NPT		
-V4-M8-5	1/2 Male NPT	1/2 Male NPT		
-V4-F12-6	3/4 Female NPT	3/4 Female NPT	0.236(6.0)	0.85
-V4-M12-F12-6	3/4 Male NPT	3/4 Female NPT		
-V4-M12-6	3/4 Male NPT	3/4 Male NPT		
-V4-F16-8	1 Female NPT	1 Female NPT	0.315(8.0)	1.62
-V4-M16-F16-8	1 Male NPT	1 Female NPT		
-V4-M16-8	1 Male NPT	1 Male NPT		

C-LOK

Instrument Valve Co., Ltd.

C-LOK the high quality instrumentation valves & fittings specialized production manufacture



Hexagonal bar Stock Needle Valves

V5 Series

Features

- Pressure up to 6000 psig(414 bar) for standard series
- Pressure up to 10000 psig(689 bar) for high pressure series
- Temperature from -65°F to 450°F (-54°C to 232°C)
- with PTFE packing,
- Temperature from -65°F to 1200°F (-54°C to 649°C)
- with Grafoil packing
- Hexagonal valve body
- Non-rotating stem tip
- Packing below stem thread isolates the threads
- lubricants from the media
- Body to bonnet seal with metal to metal constant compression,
- isolates bonnet thread from the media
- Back seating design protects the packing in fully
- Open position
- Panel mountable
- 100% factory tested

Flow Data at 100°F (38°C)

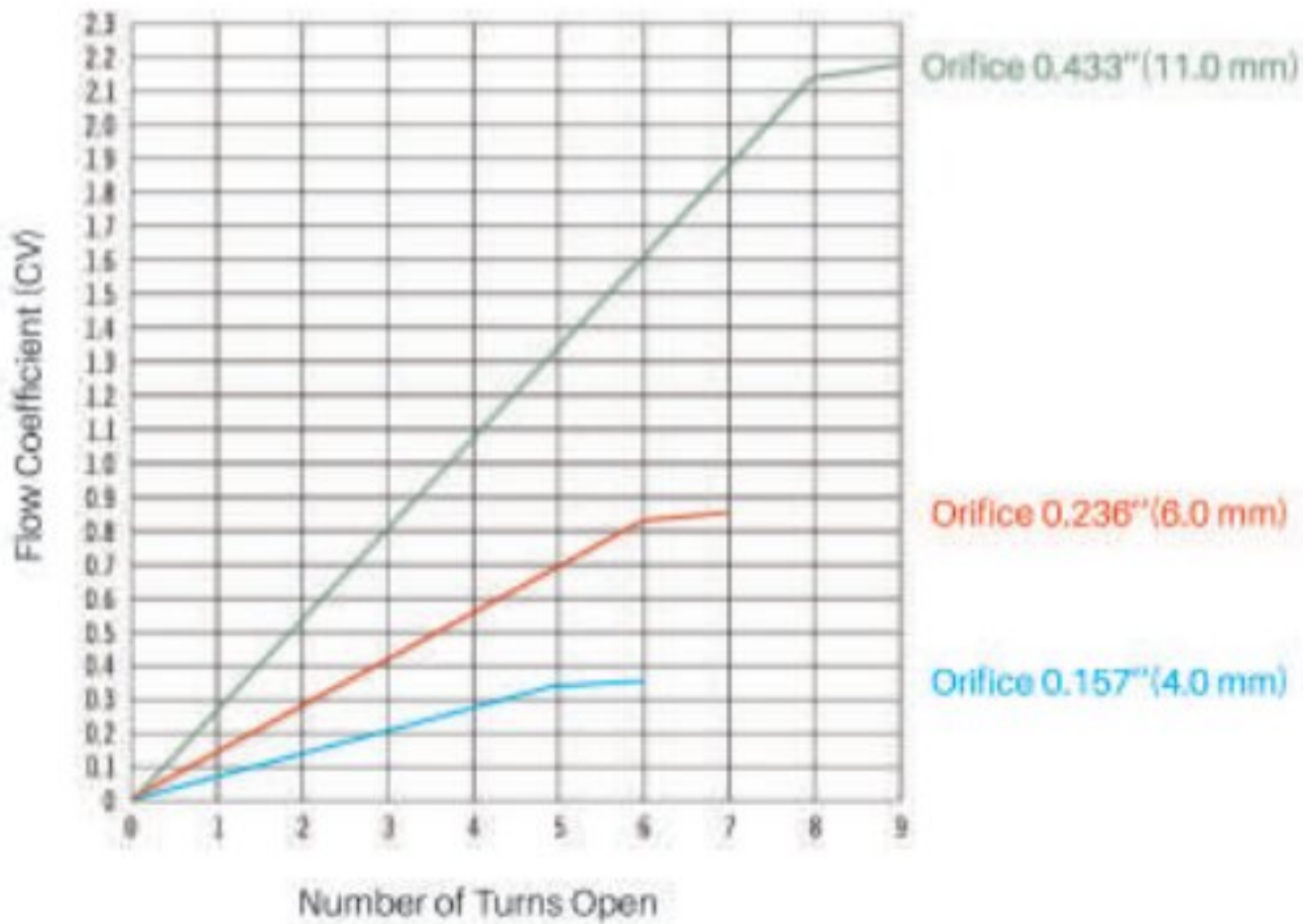

Hexagonal bar Stock Needle Valves

V5 Series

Technical Data

Standard pressure series(V5)

Temperature		Valve body material				
		316 SS	Alloy 400	Alloy C-276	Titanium	Brass
°F	°C	Working pressure, psig (bar)				
-65~100	-53~37	6000(414)	5000(344)	6000(414)	3570(245)	3000(207)
200	93	5160(356)	4400(303)	6000(414)	3110(214)	2350(162)
250	121	4910(338)	4260(293)	6000(414)	2840(195)	2200(151)
300	148	4660(321)	4120(283)	6000(414)	2570(177)	2050(141)
350	176	4470(307)	4050(279)	5975(411)	2385(164)	1470(101)
400	204	4280(295)	3980(274)	5880(405)	2200(151)	390(27)
450	232	4130(285)	3970(273)	5710(393)	2055(141)	
500	260	3980(274)	3960(272)	5540(381)	1885(129)	
600	315	3760(259)		5040(347)	1625(111)	
650	343	3690(254)		4905(337)		
700	371	3600(248)		4730(325)		
750	399	3510(242)		4430(305)		
800	426	3460(238)		4230(291)		
850	454	3380(232)		4060(279)		
900	482	3280(225)		3745(258)		
950	510	3220(221)		3220(221)		
1000	538	3030(208)		3030(208)		
1050	566	3000(207)		3000(207)		
1100	593	2685(184)		2685(184)		
1150	621	2285(157)		2285(157)		
1200	649	1715(118)		1545(106)		

Hexagonal Bar Stock Needle Valve

V5 Series

Technical data

High pressure series(V5H)

Temperature		Valve body material
		316 SS
°F	°C	Working pressure, psig (bar)
-65~100	-53~37	10000(689)
200	93	9290(640)
250	121	8840(609)
300	148	8390(578)
350	176	8045(554)
400	204	7705(530)
450	232	7435(512)
500	260	7165(493)
600	315	6770(466)
650	343	6660(458)
700	371	6480(446)
750	399	6335(436)
800	426	6230(429)
850	454	6085(419)
900	482	5905(406)
950	510	5795(399)
1000	538	5450(375)
1050	566	5400(372)
1100	593	4835(333)
1150	621	4115(283)
1200	649	3085(212)

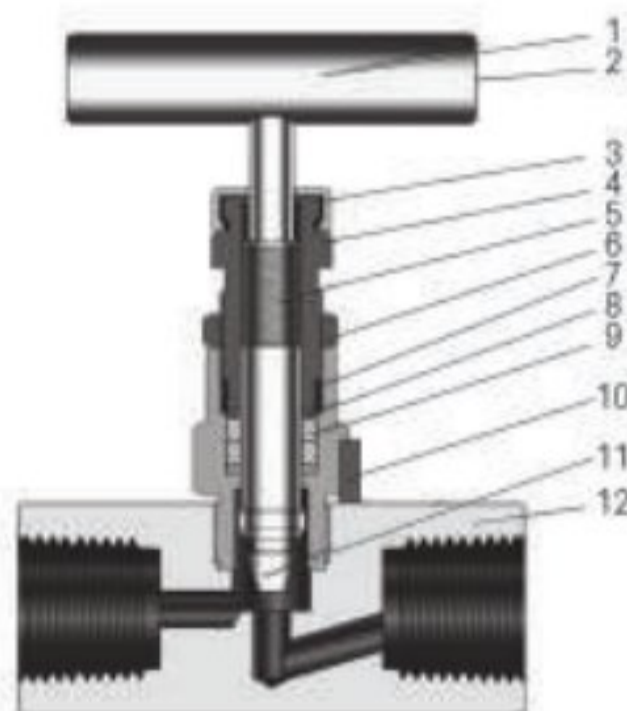

Hexagonal Bar Stock Needle Valve

V5 Series

Material of Construction

Item	Part	Valve Body Material				
		316 SS	Alloy 400	Alloy C-276	Titanium	Brass
1	Handle	Stainless steel / Anodized aluminum / Black knob				
2	Set screw	Nickel cadmium-plated steel				
3	Dust cap	Plastic				
4	Gland	316 SS/A276				Brass 360/B16
5	Stem	Chrome-plated 316 SS/A276	Alloy R-405/B164	Alloy C-276/B574	184.8373.Titanium Gr 4/B348	Chrome-plated 316 SS/A276
6	Lock nut	316 SS/B783				Brass 360/B16
7	Bonnet	316 SS/A479	Alloy R-405/B164	Alloy C-276/B574	Titanium Gr 4/B348	Brass 360/B16
8	Packing washer	316 SS/A276				
9	Packing	PTFE / PCTFE / PEEK / Grafoil				
10	Lock pin	304 SS/A276				
11	Stem tip	Chrome-plated 316 SS/A276	Alloy R-405/B164	Alloy C-276/B574	184.8373.Titanium Gr 4/B348	Chrome-plated 316 SS/A276
		Different tips optional				
12	Body	316 SS/A479 316 SS/A182	Alloy 400/B164, B127, B564	Alloy C-276/B564	Titanium Gr 4/B348 or Titanium Gr 4/B381	Brass 360/B16
	Seat	Weld stellite optional				
	Lubricant	Molybdenum disulfide-based				

Hexagonal Bar Stock Needle Valve

V5 Series

Technical data

High pressure series(V5H)

Basic Model Number	End Connection		Orifice in.(mm)	Cv
	Inlet	Outlet		
-V5-F4-4	1/4 Female NPT	1/4 Female NPT	0.157 (4.0)	0.35
-V5-M4-F4-4	1/4 Male NPT	1/4 Female NPT		
-V5-S4-4	1/4" OD	1/4" OD		
-V5-F6-4	3/8 Female NPT	3/8 Female NPT		
-V5-S6-4	3/8" OD	3/8" OD		
-V5-SM8-4	8 mm OD	8 mm OD		
-V5-F8-4	1/2 Female NPT	1/2 Female NPT		
-V5-M8-F8-4	1/2 Male NPT	1/2 Female NPT		
-V5-F6-5	1/2 Female NPT	1/2 Female NPT		
-V5-M8-F8-5	1/2 Male NPT	1/2 Female NPT		
-V5-S8-5	1/2" OD	1/2" OD		
-V5-SM12-5	12 mm OD	12 mm OD		
-V5-SM14-5	14 mm OD	14 mm OD		
-V5-SW8-5	1/2" Tube socket weld	1/2" Tube socket weld		
-V5-F12-5	3/4 Female NPT	3/4 Female NPT		
-V5-M12-F12-5	3/4 Male NPT	3/4 Female NPT		
-V5-F6-6	1/2 Female NPT	1/2 Female NPT	0.236 (6.0)	0.85
-V5-M8-F8-6	1/2 Male NPT	1/2 Female NPT		
-V5-F12-6	3/4 Female NPT	3/4 Female NPT		
-V5-M12-F12-6	3/4 Male NPT	3/4 Female NPT		
-V5-S12-6	3/4" OD	3/4" OD		
-V5-SM14-6	14 mm OD	14 mm OD		
-V5-SM16-6	16 mm OD	16 mm OD		
-V5-SW12-6	3/4" Tube socket weld	3/4" Tube socket weld		



Toggle Valves

V10 Series

Features

- Maximum working pressure: 300 psig (20.7 bar)
- Straight and angle pattern
- Compact design
- Quick opening or closing
- Nonrotating stemtip
- Leak-tight perform once testing for every valve with nitrogen at the maximum working pressure

Technical Data

Orifice	Working Pressure at 100°F(37°C)
2.0 mm	300 psig
3.2 mm	
6.4 mm	200psig

O-ring Material	Tem perature Rating
FKM (Standard)	-20°F to 200°F (-28°C to 93°C)
Buna N	-20°F to 250°F (-28°C to 121°C)
Buna C	-20°F to 250°F (-53°C to 121°C)
Ethylene Propylene	-20°F to 250°F (-28°C to 121°C)

C-LOK

Instrument Valve Co., Ltd.

C-LOK the high quality instrumentation valves & fittings specialized production manufacture



Toggle Valves

V10 Series

Standard Materials of Construction

Item	Component	Valve Body Material			
		316 SS	304 SS	321 SS	Brass
1	Handle	Stainless steel			
2	Pin	Stainless steel			
3	Stem	316 ss/A276	304 SS/A276		
4	Panel Nut	304 SS/A276			Brass 360/B16
5	Spring	PTFE-plated S17700/A313			
6	Bonnet	316 SS/A276	316 SS/B783	321 SS/A276	Brass 360/B16
7	O-ring	Fluorocarbon FKM			
8	Stem Tip	PTFE/D1710			
9	Body	316 SS/A182	304 SS/A182	321 SS/A182	Brass 377/B283
Lubricant		Molybdenum disulfide-based and silicone-based			



Toggle Valves

V10 Series

Dimensions

Basic Ordering Number	Connection Type and Size		Orifice in.(mm)	Cv
	Inlet	Outlet		
-V10-F2-2	1/8 Male NPT	1/8 Male NPT	0.08 (2.0)	0.11
-V10-M2-S2-2	1/8 Male NPT	1/8" OD		
-V10-S2-2	1/8" OD	1/8" OD		
-V10-SM3-2	3 mm OD	3 mm OD		
-V10-F2-3	1/8 Female NPT	1/8 Female NPT	0.125 (3.2)	0.20
-V10-M2-3	1/8 Male NPT	1/8 Male NPT		
-V10-M4-3	1/4 Male NPT	1/4 Male NPT		
-V10-M4-S4-3	1/4 Male NPT	1/4" OD		
-V10-S4-3	1/4" OD	1/4" OD		
-V10-SM6-3	6 mm OD	6 mm OD		
-V10-SM8-3	8 mm OD	8 mm OD		
-V10-F4-6	1/4 Female NPT	1/4 Female NPT		
-V10-F6-6	3/8 Female NPT	3/8 Female NPT		
-V10-M6-6	3/8 Male NPT	3/8" Male NPT		
-V10-S6-6	3/8" OD	3/8" OD		
-V10-S8-6	1/2" OD	1/2" OD		
-V10-SM10-6	10 mm OD	10 mm OD		
-V10-SM12-6	12 mm OD	12 mm OD		
-V10-MM20-6	M20×1.5 Male ISO	M20×1.5 Male ISO		
-V10-MM22-6	M22×1.5 Male ISO	M22×1.5 Male ISO		

C-LOK

Instrument Valve Co., Ltd.

“BALL VALVE

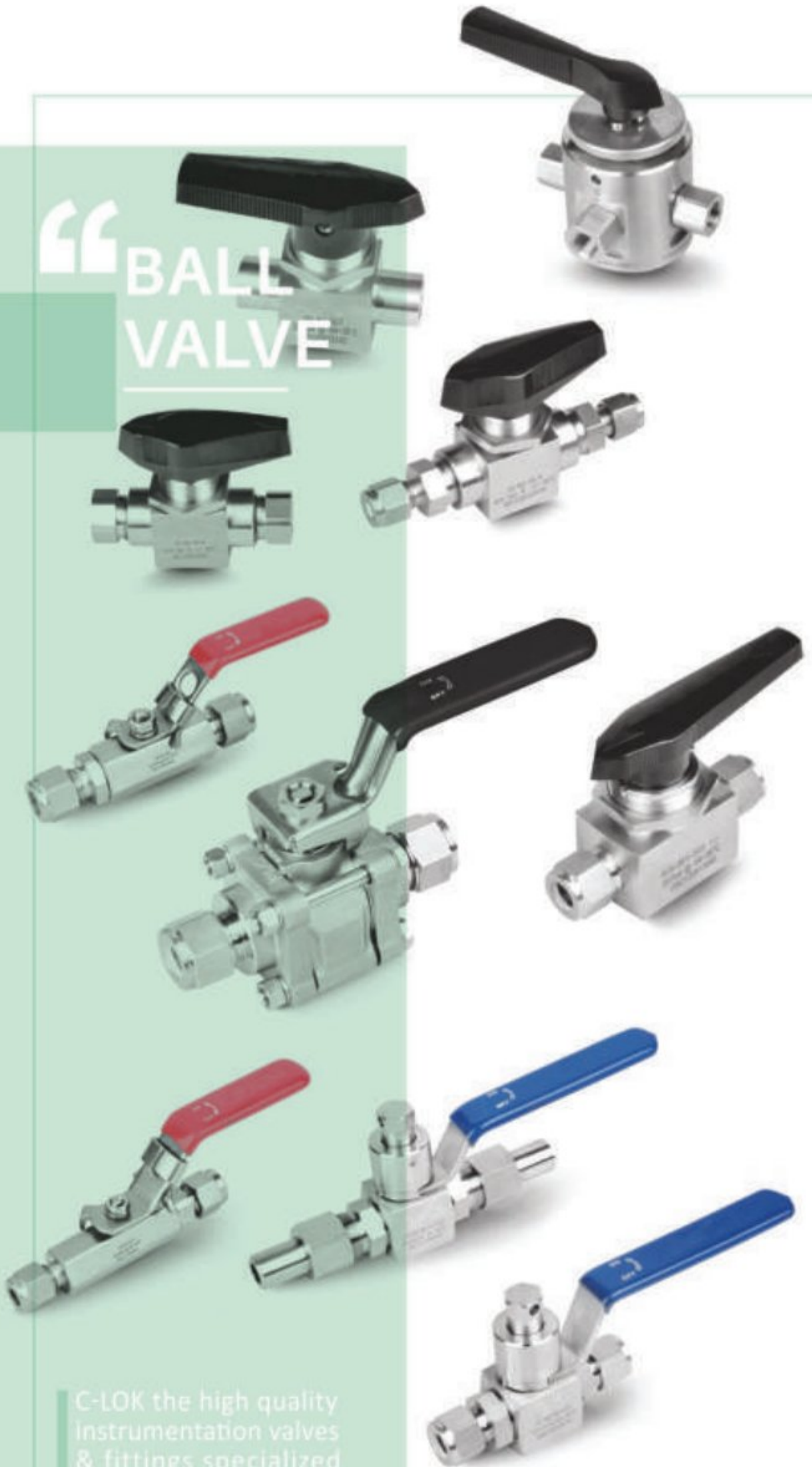

C-LOK the high quality instrumentation valves & fittings specialized production manufacture

C-LOK

Instrument Valve Co., Ltd.

C-LOK the high quality instrumentation valves & fittings specialized production manufacture



One-pieces Ball Valves

B1 Series

Features

- Working pressure up to 3000 psig (207 bar)
 - Working temperature from -65°F to 300°F (-54°C to 148°C)
 - 2-way, 3-way models for on-off and switching service available
 - One piece body and one piece ball stem eliminates multiple seal points
 - Top entry design allows in-line inspection and repair after system depressurizing, simplifies maintenance
 - Live-loading with packing springs compensates for thermal effects and wear
 - Pneumatic and electric actuation available
 - Panel mountable
- 100% factory tested

Technical Data

Temperature		Working pressure, psig (bar)
°F	°C	
-65~50	-54~10	3000(207)
50~150	10~65	3000(207)
200	93	2800(193)
250	121	2650(182)
300	148	2500(172)





One - piece Instrument Ball Valves

B1 Series

Dimensions

Item	Component	Valve Body Materials		
		Stainless Steel	Brass	Alloy 400
		Material Grade/ASTM Specification		
1	Handle	Aluminum alloy		
2	Set screw	302 SS		
3	Packing screw	316 SS/A176	Brass CDA 360/B16	Alloy R-405/B164
4	Panel nut	S17400S	Brass CDA 360/B16	S17400S
5	Packing springs	316 SS/A240		
6	Gland	316 SS/A276		
7	Packing seat	PTFE/Reinforced PTFE/UHMWPE		
8	Support rings	Fluorocarbon coated 316 SS/A276		Fluorocarbon coated alloy 400
9	Ball stem	316 SS/A276 and A479		Alloy R-405/B164
10	Body	316 SS/A182	Brass CDA 360/B283	Alloy 400/B564
	Lubricant	Hydrocarbon-based and silicone-based		

One-pieces Ball Valves

B1 Series

Table of Dimension

Basic Model Number	End Connection		Orifice in. (mm)	Cv
	Port 1	Port 2/3		
-B1-S1-1	1/16"OD	1/16"OD	0.052 (1.32)	0.10
-B1-S2-2	1/8"OD	1/8"OD	0.093 (2.36)	0.20
-B1-SM3-2	3mmOD	3mmOD		
-B1-F2-3	1/8 Female NPT	1/8 Female NPT	0.125 (3.18)	0.60
-B1-S4-3	1/4"OD	1/4"OD		
-B1-SM6-3	6mmOD	6mmOD		
-B1-F2-5	1/8 Female NPT	1/8 Female NPT	0.187 (4.75)	1.5
-B1-F4-5	1/4 Female NPT	1/4 Female NPT		
-B1-FR4-5	1/4 Female BSPT	1/4 Female BSPT		
-B1-M4-5	1/4 Male NPT	1/4 Male NPT		
-B1-M4-S4-5	1/4 Male NPT	1/4"OD		
-B1-S4-5	1/4"OD	1/4"OD		
-B1-S6-5	3/8"OD	3/8"OD		
-B1-SM6-5	6mmOD	6mmOD		
-B1-SM8-5	8mmOD	8mmOD	0.281 (7.14)	6.0
-B1-F4-7	1/4 Female NPT	1/4 Female NPT		
-B1-F6-7	3/8 Female NPT	3/8 Female NPT		
-B1-FR6-7	3/8 Female BSPT	3/8 Female BSPT		
-B1-S6-7	3/8"OD	3/8"OD		
-B1-SM10-7	10mmOD	10mmOD		
-B1-SM12-7	12mmOD	12mmOD	0.406 (10.3)	12
-B1-SM14-7	14mmOD	14mmOD		
-B1-F8-10	1/2 Female NPT	1/2 Female NPT		
-B1-FR8-10	1/2 Female BSPT	1/2 Female BSPT		
-B1-S8-10	1/2"OD	1/2"OD		
-B1-S12-10	3/4"OD	3/4"OD		
-B1-SM12-10	12mmOD	12mmOD		
-B1-SM14-10	14mmOD	14mmOD	14mmOD	
-B1-SM16-10	16mmOD	14mmOD		

C-LOK

Instrument Valve Co., Ltd.

C-LOK the high quality instrumentation valves & fittings specialized production manufacture



Hex Bar Stock Ball Valves

B2 Series

Features

- Working pressure up to 2000 psig (138 bar)
- Working temperature from -65°F to 450°F (-54°C to 232°C)
- Size from 1/8" to 1" or mm to 25 mm
- Compact design with one piece hexagon body
- Low torque for easy operation
- Free floating ball design provides seat wear compensation
- depressurizing, simplifies maintenance
- 100% factory tested

Technical Data

Temperature		Working pressure, psig (bar)
°F	°C	
-65-100	-54-37	2000(138)
150	65	1820(125)
200	93	1650(113)
250	121	1480(101)
300	148	1310(90)
350	176	1140(79)
400	204	970(67)
450	232	800(55)



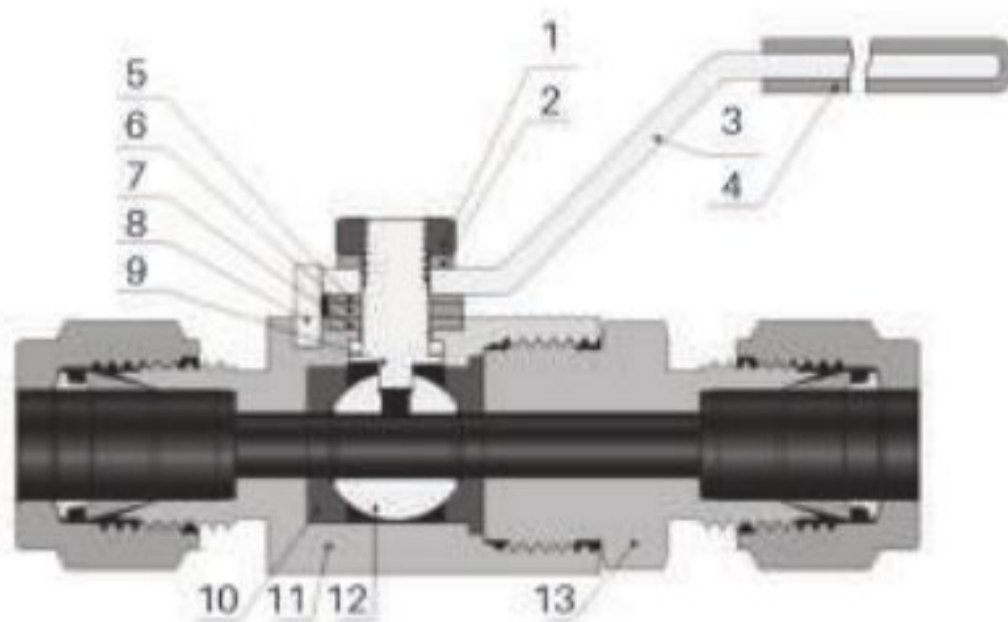

Hex Bar Stock Ball Valves

B2 Series

Standard Materials of Construction

Item	Component	Body Materials	
		316 SS	Brass
1	Stem nut	316 SS	
2	Spring washer	Spring steel	
3	Handle	316 SS	
4	Handle sleeve	Vinyl	
5	Washer	304 SS	
6	Gland	316 SS/A276	
7	Packing	PTFE (TFM1600)	
8	Stop pin	316 SS/A276	
9	Stem	316 SS/A276	
10	Seat	Reinforced PTFE	
11	Body	316 SS/ A276	Brass/ B453
12	Ball	316 SS/A479	
13	End connectorf	316 SS/ A276	Brass/ B453



Hex Bar Stock Ball Valves

B2 Series

Table of Dimentions

Basic Model Number	End Connection		Orifice in. (mm)	Cv
	Port 1	Port 2/3		
-B2-F2-5	1/8 Female NPT	1/8 Female NPT	0.197 (5.0)	1.25
-B2-F4-5	1/4 Female NPT	1/4 Female NPT		
-B2-FR4-5	1/4 Female BSPT	1/4 Female BSPT		
-B2-S4-5	1/4" OD	1/4" OD		
-B2-SM6-5	6mm OD	6mm OD		
-B2-F6-7	3/8 Female NPT	3/8 Female NPT	0.28 (7.1)	2.5
-B2-FR6-7	3/8 Female BSPT	3/8 Female BSPT		
-B2-S6-7	3/8" OD	3/8" OD		
-B2-SM8-7	8mm OD	8mm OD		
-B2-SM10-7	10mm OD	10mm OD		
-B2-F8-9	1/2 Female NPT	1/2 Female NPT	0.35 (9.0)	9.25
-B2-FR8-9	1/2 Female BSPT	1/2 Female BSPT		
-B2-S8-9	1/2" OD	1/2" OD		
-B2-SM12-9	12mm OD	12mm OD		
-B2-F12-13	3/4 Female NPT	3/4 Female NPT		
-B2-FR12-13	3/4 Female BSPT	3/4 Female BSPT		
-B2-S10-13	5/8" OD	5/8" OD		
-B2-S12-13	3/4" OD	3/4" OD		
-B2-SM14-13	14mm OD	14mm OD		
-B2-SM16-13	16mm OD	16mm OD	0.63 (16.0)	17.35
-B2-F16-16	1 Female NPT	1 Female NPT		
-B2-FR16-16	1 Female BSPT	1 Female BSPT		
-B2-S16-16	1" OD	1" OD		
-B2-SM25-16	25mm OD	25mm OD		



Trunnion Ball Valves

B3 Series

Features

- Maximum working pressure 6000 - 10000 psig (690 bar)
- Working temperature: 0°F to 450°F (-17°C to 232°C)
- Fixed ball with double sealing
- Automatic compensation of seat sealing
- Low operating torque
- Blowout proof stem
- Handle as indicator of flow direction
- Positive handle stop
- Pneumatic or electric actuator available
- Panel mountable
- Options for handle color
- Leak-tight performance testing with nitrogen for every Valve at the maximum working pressure, but not higher than 6000 psig

Pressure VS. Temperature

B3 Series

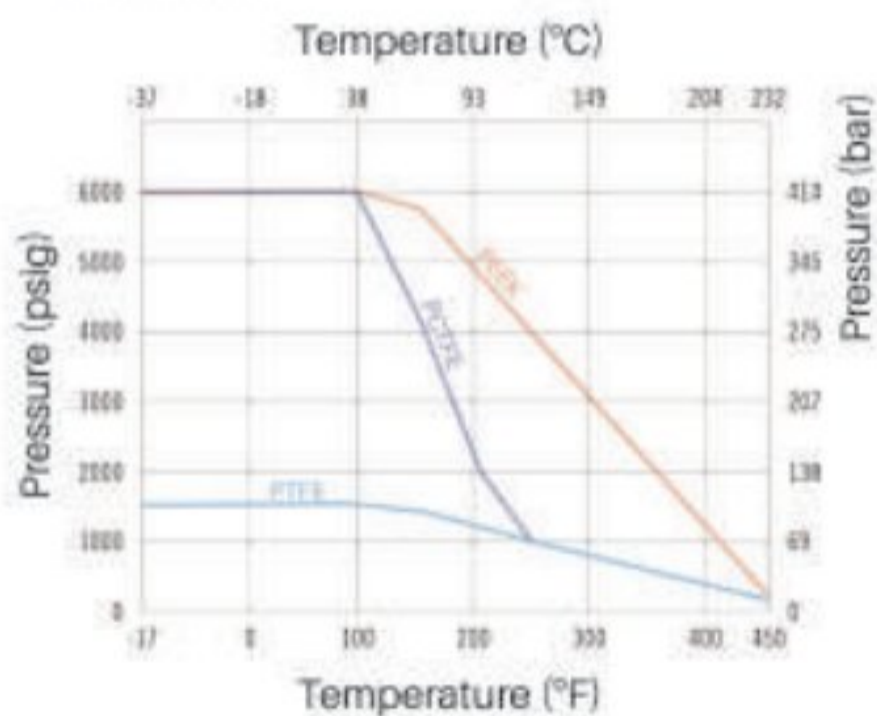

B3H Series

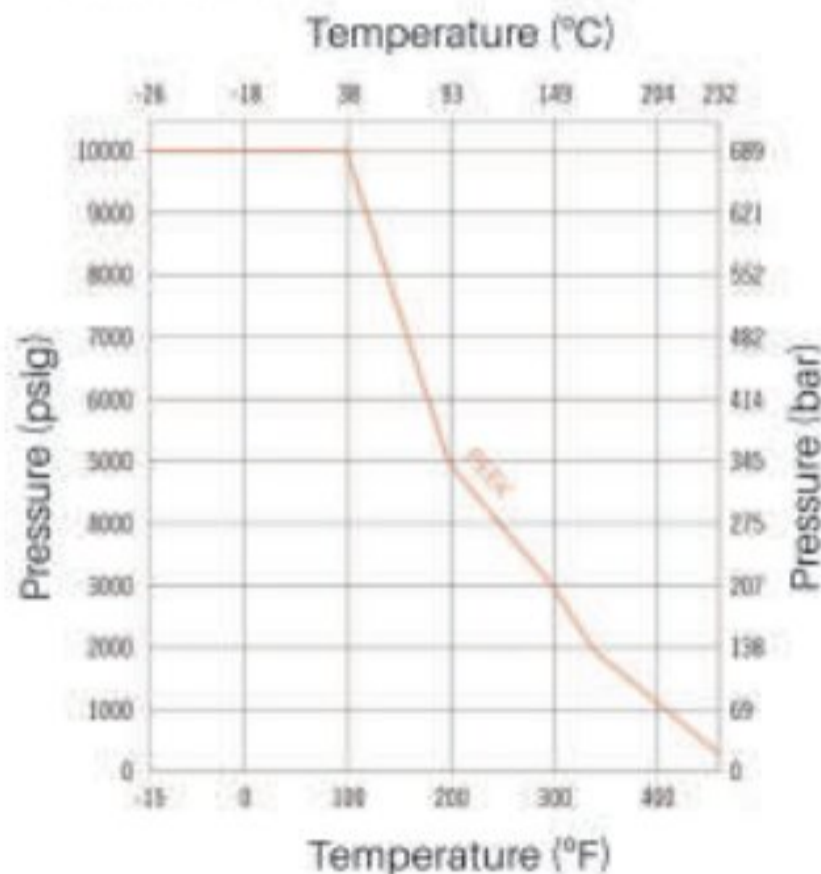

1. Graphs are for 2-way Valves only

2. Maximum working pressure for 3-way Valves:

6000 psig: connection 1 as inlet, connection 2 and connection 3 as outlet

3000 psig: connection 1 as inlet, connection 3 and connection 1 as outlet

Trunnion Ball Valves

B3 Series

Standard Materials of Construction

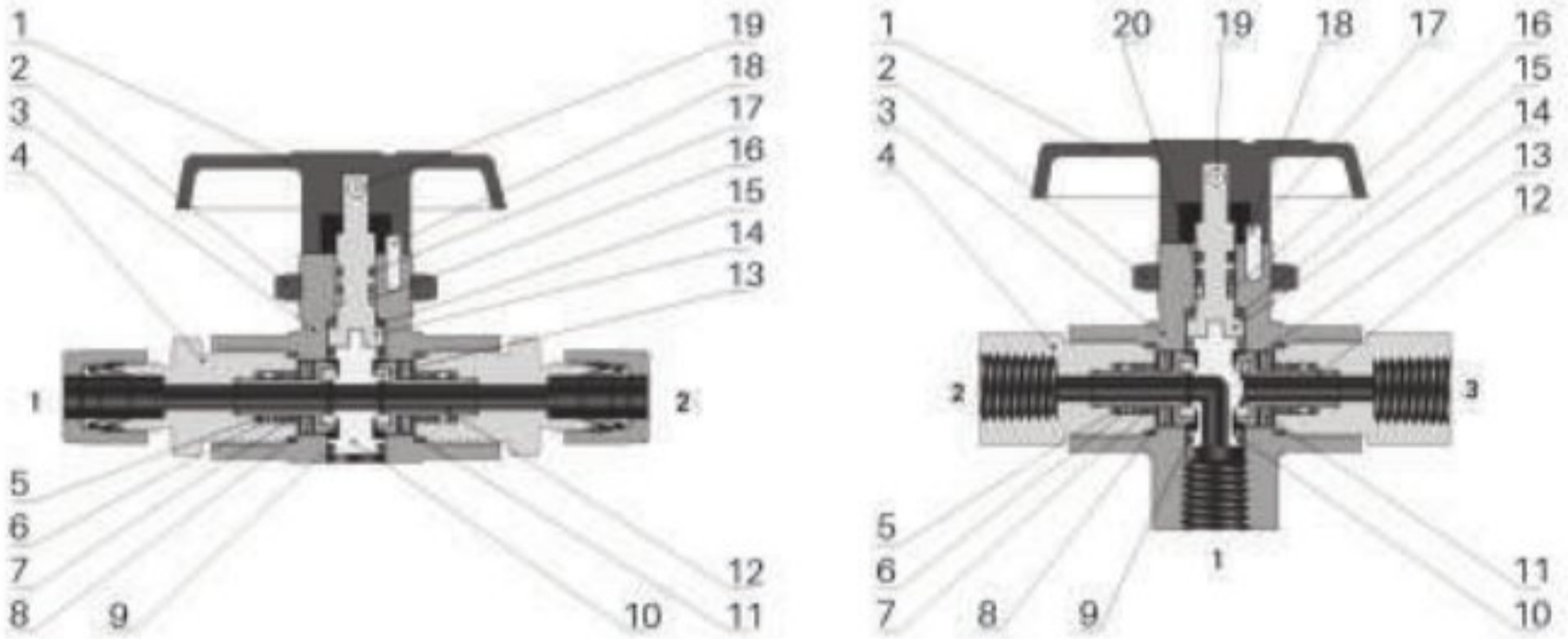

Item	Component	Valve Body Material			
		316 Stainless Steel		Alloy 400	
		2-way	3-way	2-way	3-way
Material Grade/ASTM Specification					
1	Handle	Nylon or aluminum			
2	Panel Nut	316 SS/B783			
3	Body	316 SS/A479		Alloy 400/B164	
4	End Connector	316 SS/A479		Alloy R-405/B164	
5	Seat Retainer Guide	Reinforced PTFE			
6	Seat Retainer O-ring	Fluorocarbon FKM			
7	Seat Carrier Guide	316 SS/A276		Alloy R-405/B164	
8	End Connector Seal	PTFE/D1710			
9	Trunnion Bearing	Fluorocarbon FKM	PEEK	Fluorocarbon FKM	PEEK
10	Ball	316 SS/A276	S21800/A276	Alloy R-405/B164	
11	Seat Spring	Alloy X-750/AMS 5542			
12	Seat Retainer	316 SS/A276		Alloy R-405/B164	
13	Seat	PTFE or PEEK or PC1FE			
14	Stem	316 SS/A276		Alloy R-405/B164	
15	Stem Washer	Reinforced PTFE	PEEK	Reinforced PTFE	PEEK
16	Stem O-ring	—	Fluorocarbon FKM	—	Fluorocarbon FKM
17	Primary Stem Backup Ring	PTFE/D1710			
18	Pin	Stainless Steel			
19	Set Screw	S17400 SS			
20	Secondary Stem Backup Ring	—	PEEK	—	PEEK
	Lubricants	Molybdenum and Tungsten disulfide and Fluorinated-based			

Trunnion Ball Valves

B3 Series

Dimensions

2-way Valve

Basic Ordering Number	Connection Size		Cv
	Connection 1	Connection 2	
B3 Series			
-B3-F2	1/8 Female NPT	1/8 Female NPT	1.2
-B3-F4	1/4 Female NPT	1/4 Female NPT	

-B3-F8	1/2 Female NPT	1/2 Female NPT	
-B3-S4	1/4" OD	1/4" OD	
-B3-S6	3/8" OD	3/8" OD	
-B3-S8	1/2" OD	1/2" OD	
-B3-SM6	6 mm OD	6 mm OD	
-B3-SM8	8 mm OD	8 mm OD	
-B3-SM10	10 mm OD	10 mm OD	
-B3-SM12	12 mm OD	12 mm OD	

3-way Valve

Basic Ordering Number	Connection Size			Cv
	Connection 1	Connection 2	Connection 3	
B3 Series				
-B3-F2-3	1/4 Female NPT	1/8 Female NPT	1/8 Female NPT	0.75
-B3-F4-3		1/4 Female NPT	1/4 Female NPT	

-B3-S4-3		1/4" OD	1/4" OD	
-B3-S6-3		3/8" OD	3/8" OD	
-B3-S8-3		1/2" OD	1/2" OD	
-B3-SM6-3		6 mm OD	6 mm OD	
-B3-SM8-3		8 mm OD	8 mm OD	
-B3-SM10-3		10 mm OD	10 mm OD	
-B3-SM12-3		12 mm OD	12 mm OD	

C-LOK

Instrument Valve Co., Ltd.

C-LOK the high quality instrumentation valves & fittings specialized production manufacture

Trunnion Ball Valves

B3 Series

Service Option

B3 Series Pressure - temperature Ratings

Material	316 SS		Alloy 400	
Seat Material	PCTFE PEEK	PTFE	PCTFE PEEK	PTFE
Temperature, °F(°C)	Working Pressure, psig (bar)			
-40 to 100 (-40 to 37)	6000 (414)	1500 (103)	5000 (345)	1500 (103)
100 to 200 (37 to 93)	See Pressure vs. Temperature			



C-LOK

Instrument Valve Co., Ltd.



GAUGE VALVE & _____ INSTRUMENT MANIFOLDS



C-LOK the high quality instrumentation valves & fittings specialized production manufacture

Gauge Valves and Instrument Manifolds

Features

- Pressure up to 6000 psig (414 bar) for Standard stainless steel body
- Temperature for PTFE packing from -65°F to 450°F (-54°C to 232°C)
Temperature for Grafol packing from -65°F to 1200°F (-54°C to 649°C)
- Packing below stem thread isolates the thread lubricant from the media
- Back seating design protects the packing in fully open position
- Non-rotating stem tip
- 100% factory tested
- Orifice: 0.157" (4.0mm), CV:0.35

Standard Materials of Construction

Handle color codes for function:
 BLACK= Isolate/block
 RED= Test/vent
 GREEN=Equalize

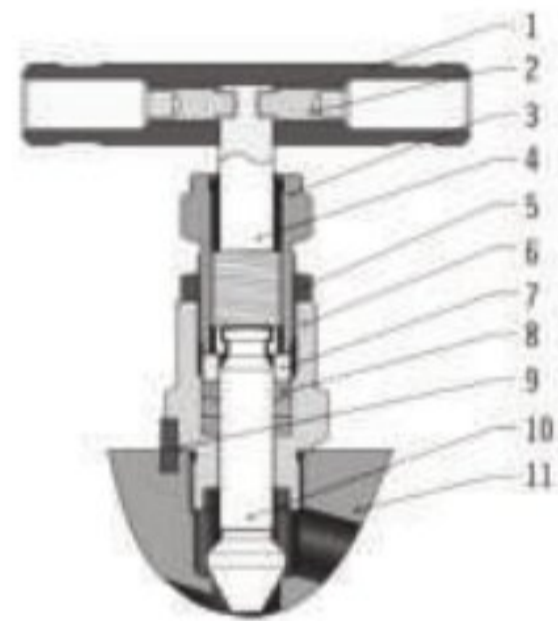

Item	Part	Valve Body Material		
		316 SS	Alloy 400	Alloy C-276
1	Handle	Anodized aluminum		
2	Set Screw	Nickel cadmium-plated steel		
3	Packing Bolt	321 SS/A276		
4	Upper Stem	316 SS/A276		
5	Lock Nut	316 SS/B783		
6	Bonnet	316 SS/A479	Alloy R-405/B164	Alloy C-276/B574
7	Gland	316 SS/A276		
8	Packing	PTFE or PEEK or graphite		
9	Lock Pin	304 SS/A276		
10	Lower Stem	Chrome-plated 316 SS/A276	Alloy R-405/B164	Alloy C-276/B574
11	Body	316 SS/A479 316 SS/A182	Alloy 400/B164, B127,B564	Alloy C-276/B564
	Lubricant	Molybdenum disulfide-based		

Process interface valves for sour gas service are available. Materials are selected in accordance with NACE MR0175/ISO 15156. Contact the authorized representative or C-LOK if any request.

C-LOK

Instrument Valve Co., Ltd.

C-LOK the high quality instrumentation valves
& fittings specialized production manufacture

Gauge Valves and Instrument Manifolds

Technical Data

Temperature		Valve body material	
		316 SS	Carbon Steel
°F	°C	Working pressure psig(bar)	
-65~100	-54~38	6000(414)	3000(207)
200	93	5160(356)	2730(188)
250	121	4910(338)	2695(185)
300	148	4660(321)	2660(183)
350	176	4470(307)	2615(180)
400	204	4280(295)	
450	232	4130(285)	
500	260	3980(274)	
60	315	3760(259)	
650	343	3690(254)	
700	371	3600(248)	
750	39	3510(242)	
800	426	3460(238)	
850	454	3380(232)	
900	482	3280(225)	
950	510	3220(221)	
1000	538	3030(208)	
1050	566	3000(207)	
1100	593	2685(184)	
1150	621	2285(157)	
1200	649	1715(118)	



C-LOK

Instrument Valve Co., Ltd.

C-LOK the high quality instrumentation valves & fittings specialized production manufacture

Two -Valves Manifolds

2D

Features

Basic Model Number	Inlet / process	Outlet / instrument	Test / vent
-2D-F8-A	1/2" Female NPT	Flange(MSS)	1/4" Female NPT

Flange Seal and Bolt Kit: PTFE(or Grafoil) sealing rings + 7/16-20UNF Bolts

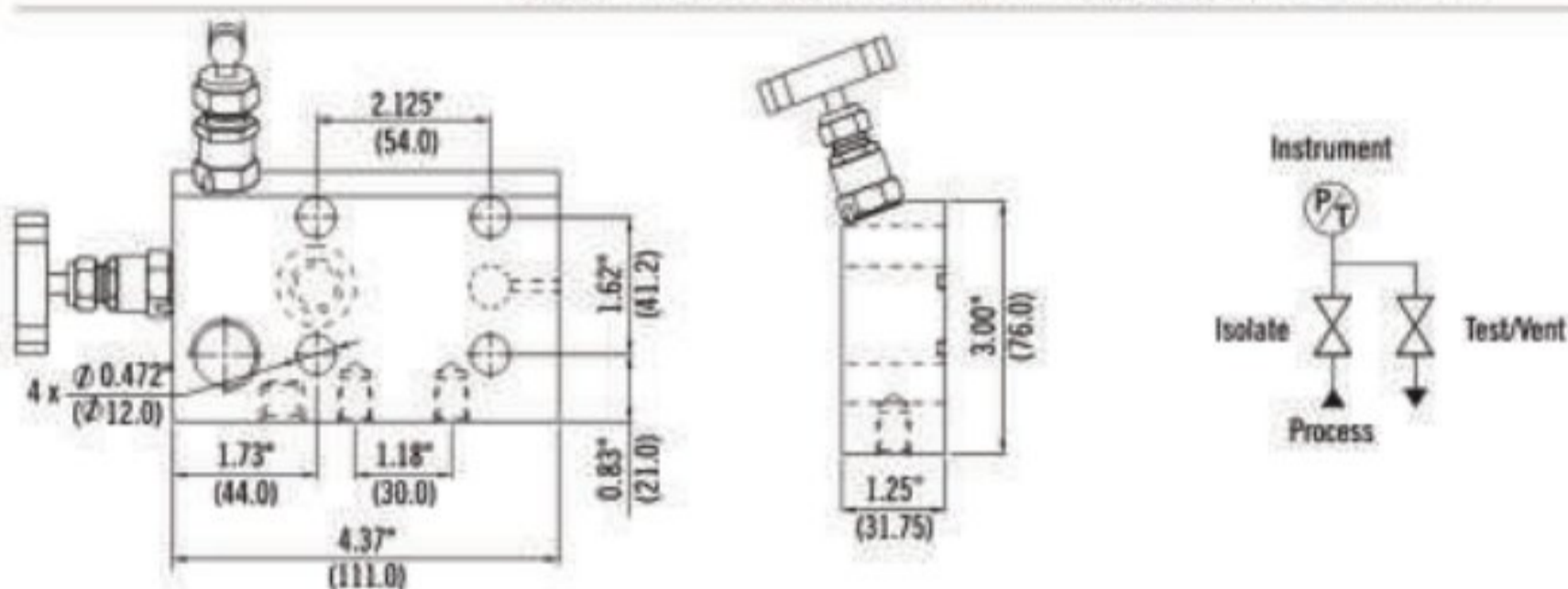

Basic Model Number	Inlet / process	Outlet / instrument	Test / vent
-2D-F8-L	1/2" Female NPT	Flange(MSS)	1/4" Female NPT

Flange Seal and Bolt Kit: PTFE(or Grafoil) sealing rings + 7/16-20UNF Bolts

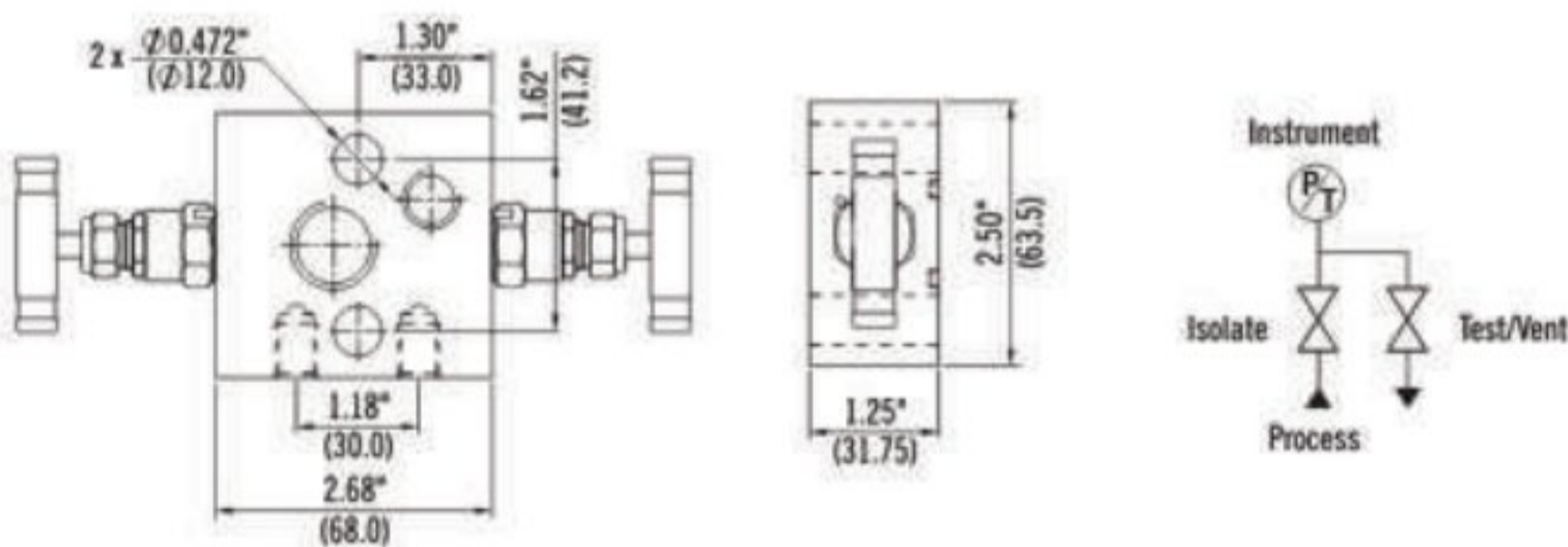

Basic Model Number	Inlet / process	Outlet / instrument	Test / vent
-2D-F8-H	1/2" Female NPT	Flange(MSS)	1/4" Female NPT

Flange Seal and Bolt Kit: PTFE(or Grafoil) sealing rings + 7/16-20UNF Bolts

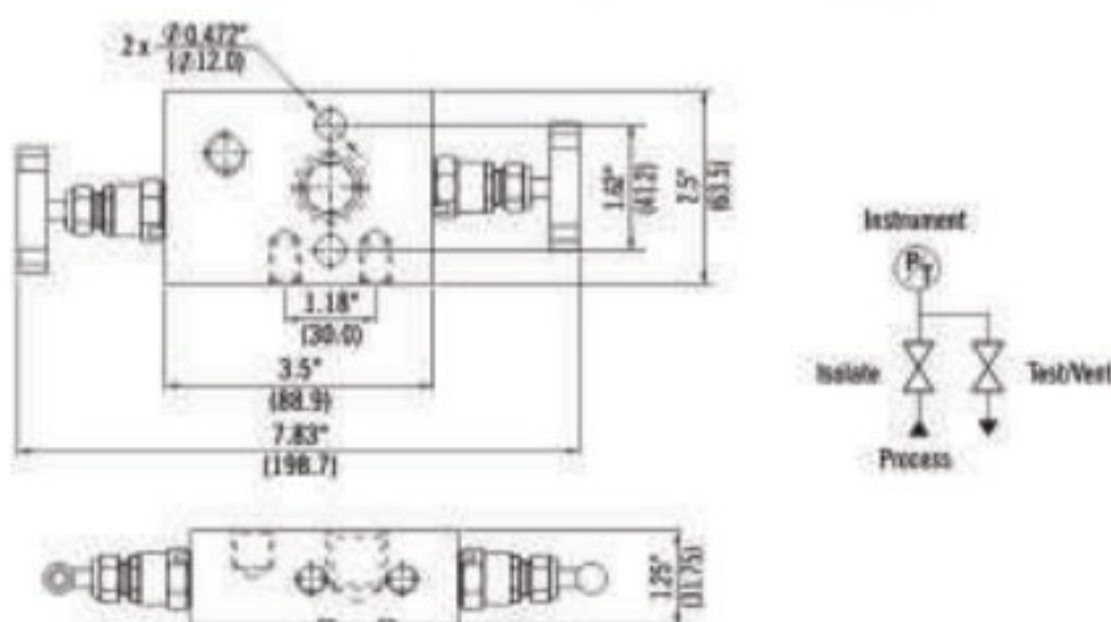

C-LOK

Instrument Valve Co., Ltd.

C-LOK the high quality instrumentation valves & fittings specialized production manufacture

Two -Valves Manifolds

2D

Features

Basic Model Number	Inlet / process	Outlet / instrument	Test / vent
-2R-F8-M8-H	1/2" Male NPT	1/2" Female NPT	1/4" Female NPT

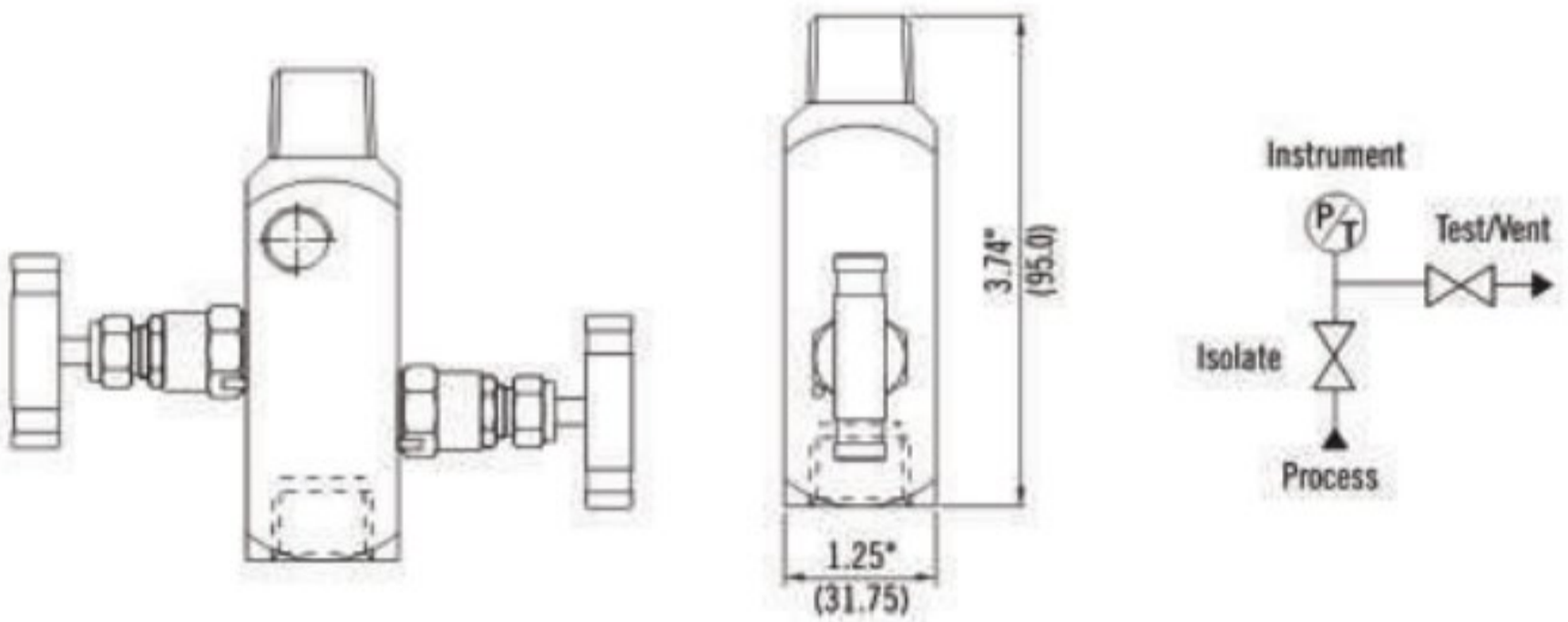

Basic Model Number	Inlet / process	Outlet / instrument	Test / vent
-2R-F8-V	1/2" Female NPT	1/2" Female NPT	1/4" Female NPT

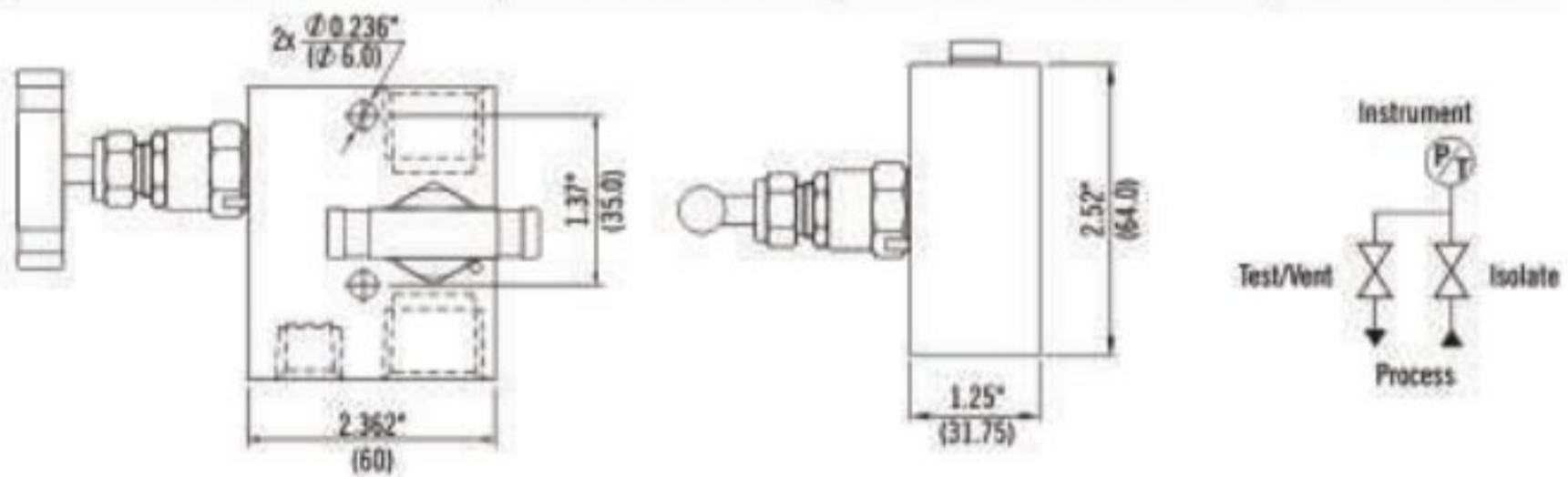

Basic Model Number	Inlet / process	Outlet / instrument	Test / vent
-2R-F4-A	1/4" Female NPT	1/4" Female NPT	1/4" Female NPT

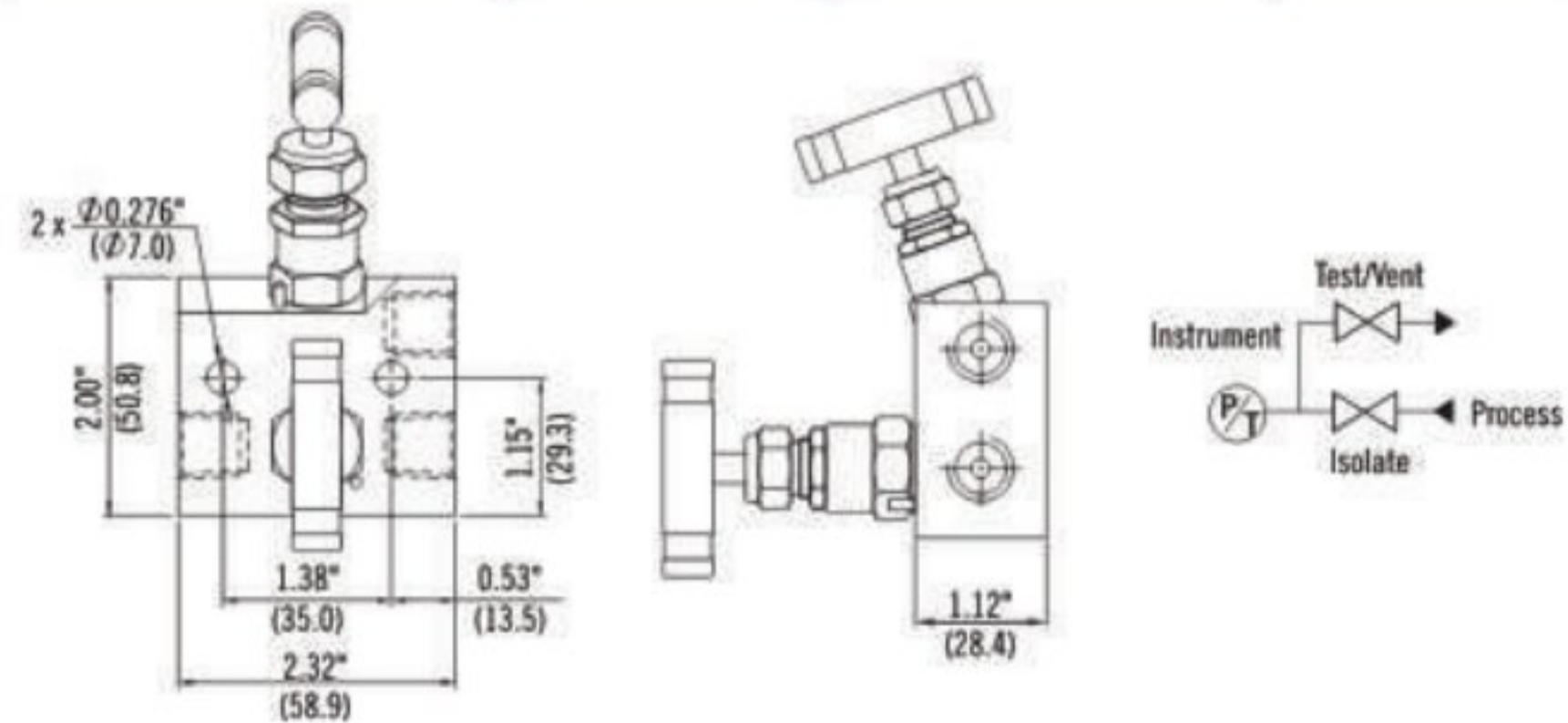

C-LOK

Instrument Valve Co., Ltd.

C-LOK the high quality instrumentation valves & fittings specialized production manufacture

Two -Valves Manifolds

2D

Features

Basic Model Number	Inlet / process	Outlet / instrument	Test / vent
-2R-F4-C	1/4" Female NPT	1/4" Female NPT	1/4" Female NPT

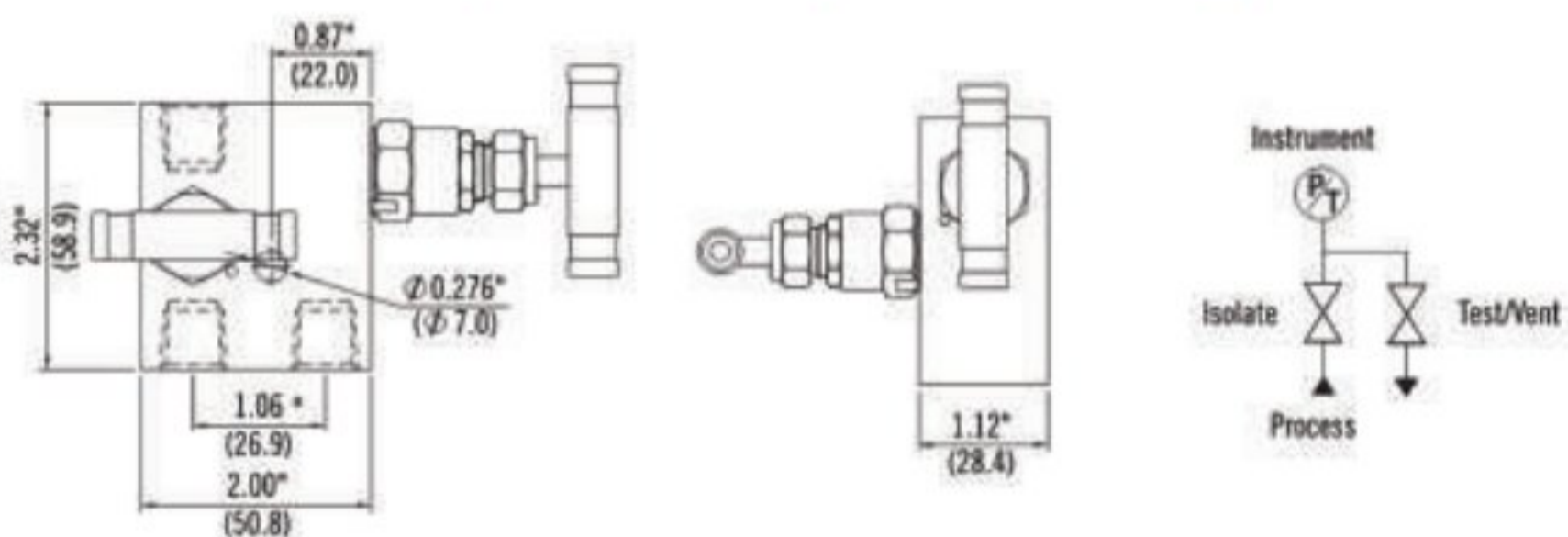

Basic Model Number	Inlet / process	Outlet / instrument	Test / vent
-2R-F8-L	1/2" Female NPT	1/2" Female NPT	1/4" Female NPT

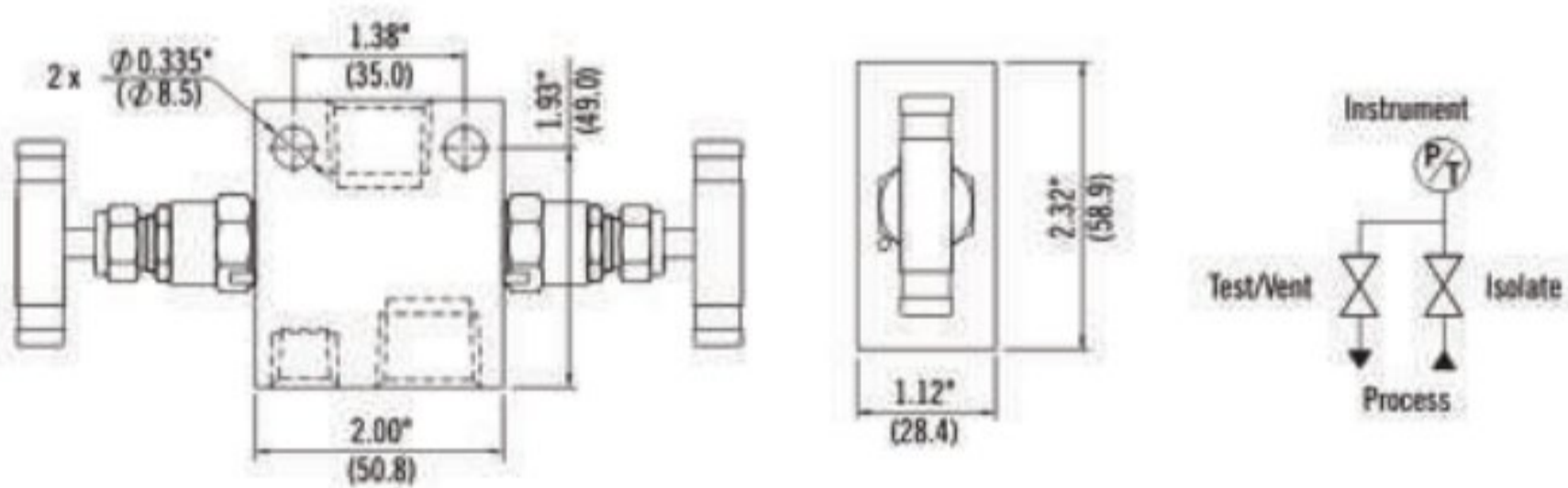

Basic Model Number	Inlet / process	Outlet / instrument	Test / vent
-2D-F8-C	1/2" Female NPT	Flange(MSS)	1/4" Female NPT

Flange Seal and Bolt Kit: PTFE(or Gratoil) sealing rings + 7/16-20UNF Bolts

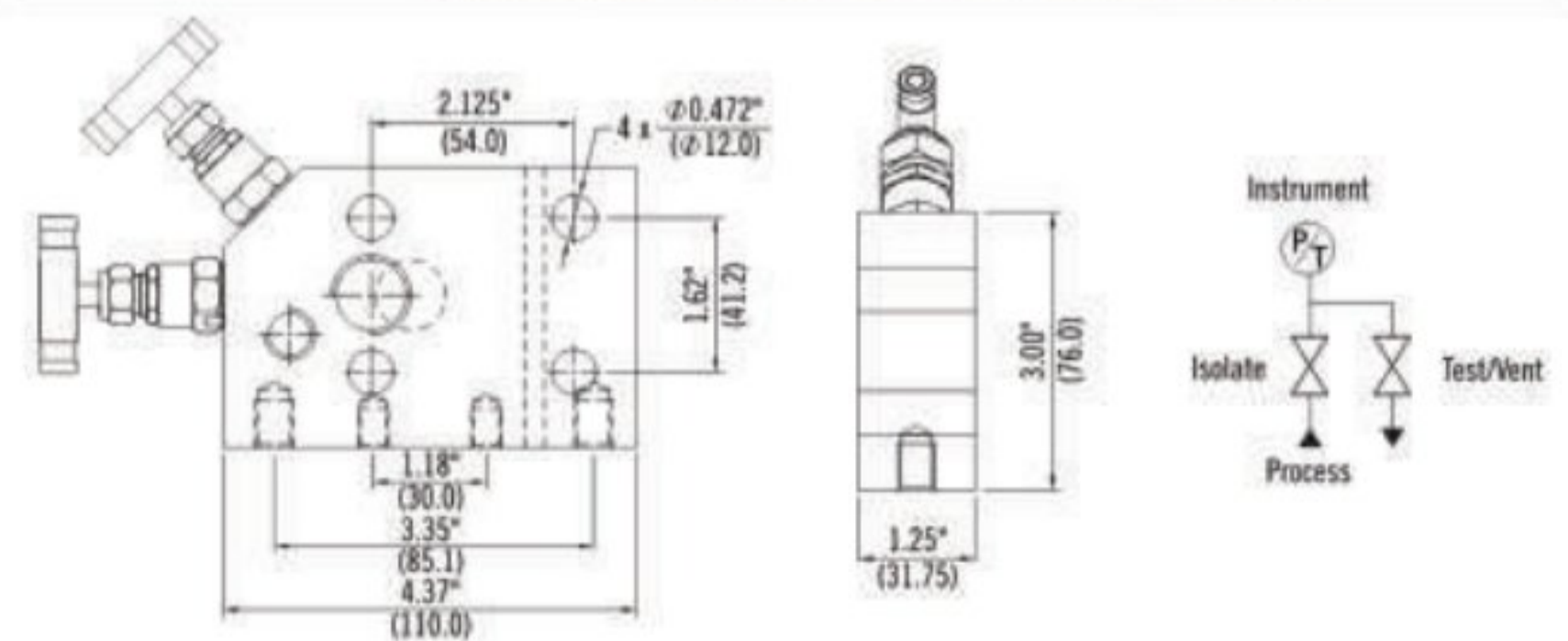

Three -Valves Manifolds

3D

Features

- Three valves in one block for isolation, equalization, bleeding of instruments.

Basic Model Number	Inlet / process	Outlet / instrument	Test / vent
-3D-F8-L	1/2" Female NPT	Flange(MSS)	Optional

Flange Seal and Bolt Kit: PTFE(or Grafoil) sealing rings + 7/16-20UNF Bolts

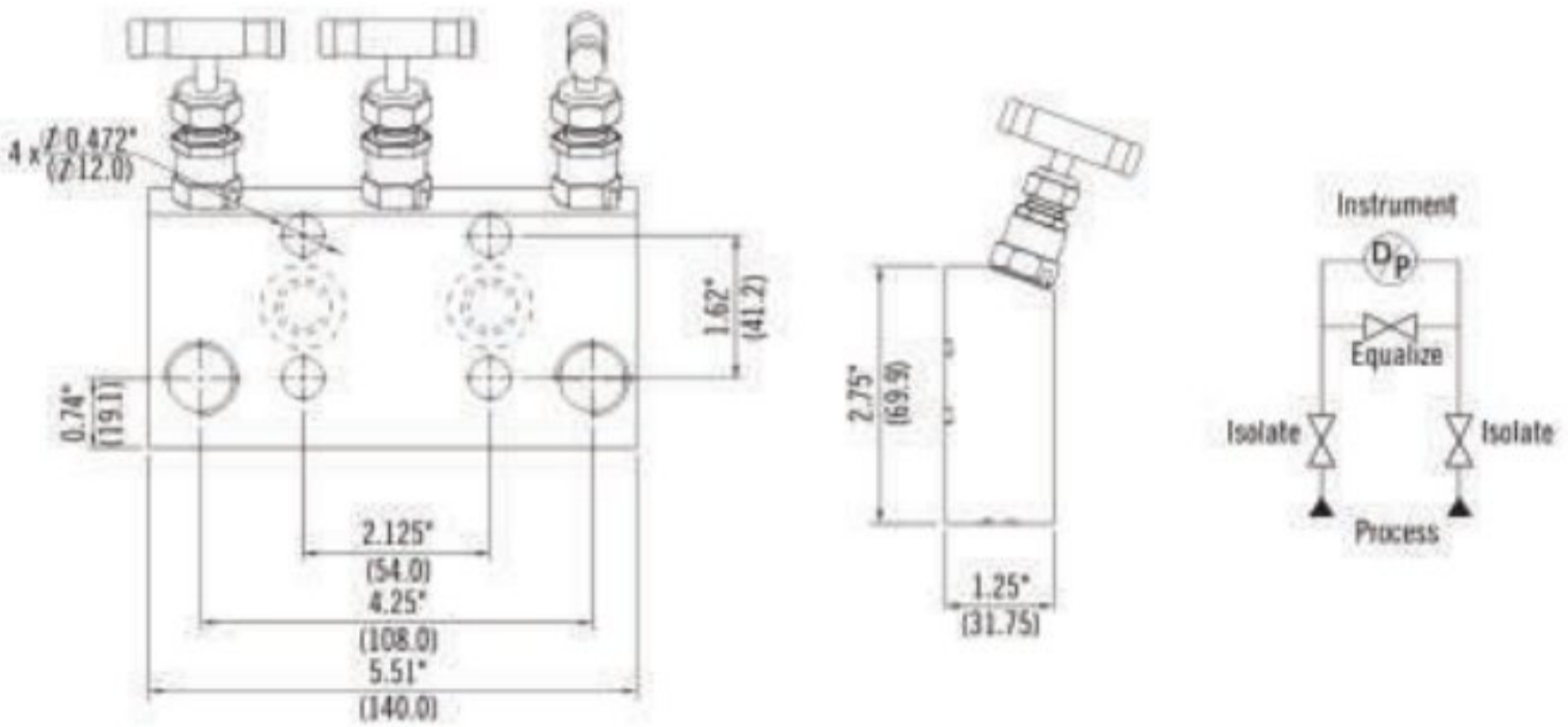

Basic Model Number	Inlet / process	Outlet / instrument	Test / vent
-3D-F8-A	1/2" Female NPT	Flange(MSS)	Optional
-3D-S8-A	1/2" C-LOK	Flange(MSS)	Optional

Flange Seal and Bolt Kit: PTFE(or Grafoil) sealing rings + 7/16-20UNF Bolts

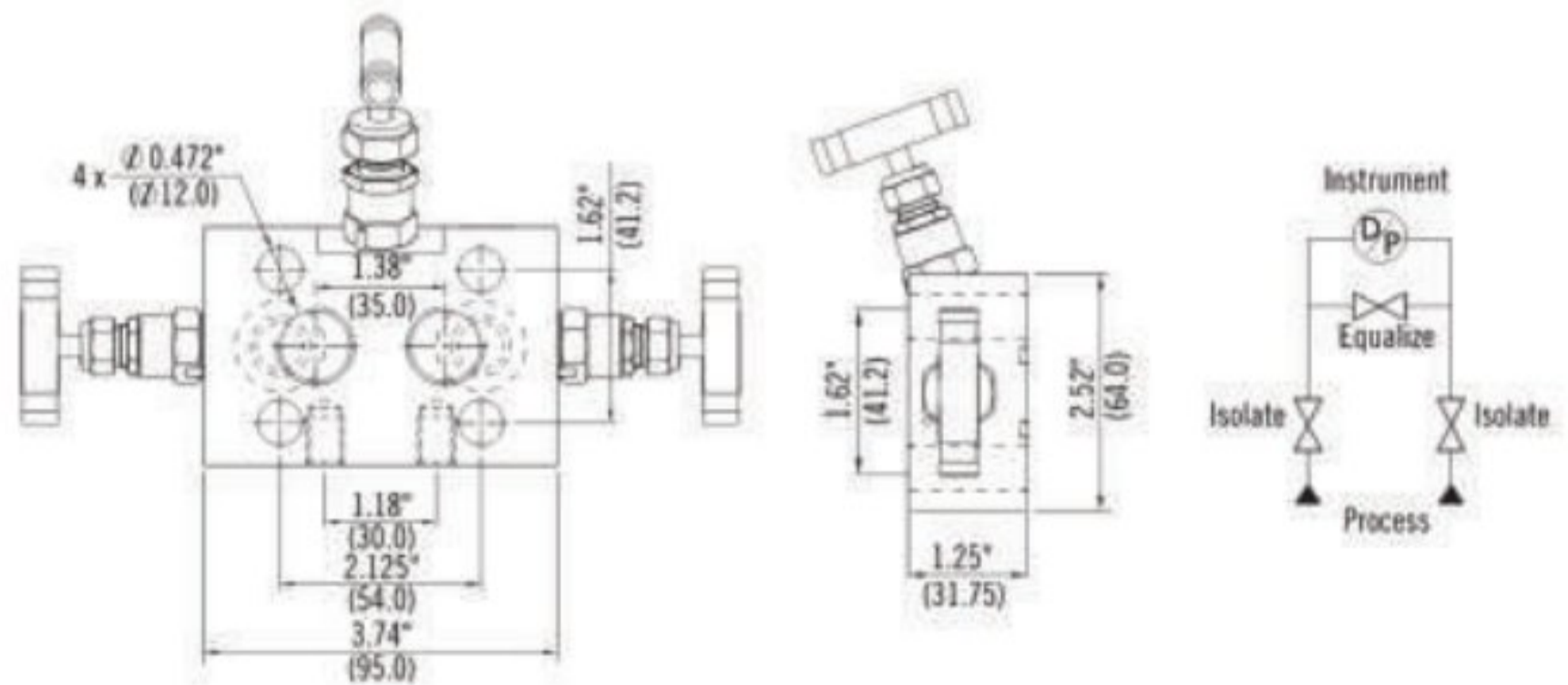

C-LOK

Instrument Valve Co., Ltd.

C-LOK the high quality instrumentation valves & fittings specialized production manufacture

Three -Valves Manifolds

3D

Features

Basic Model Number	Inlet / process	Outlet / instrument	Test / vent
-3D-F8-V	1/2" Female NPT	Flange(MSS)	Optional

Flange Seal and Bolt Kit: PTFE(or Grafoil) sealing rings + 7/16-20UNF Bolts

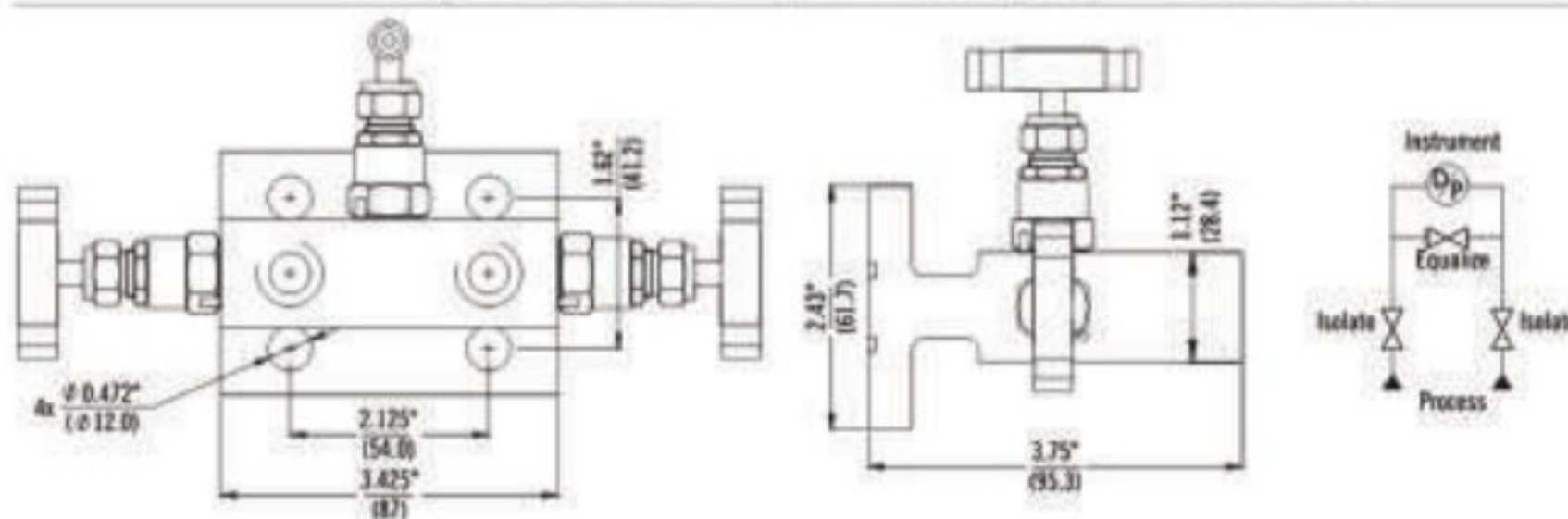

Basic Model Number	Inlet / process	Outlet / instrument	Test / vent
-3D-F8-C	1/2" Female NPT	Flange(MSS)	Optional
-3D-S8-C	1/2" C-LOK	Flange(MSS)	Optional

Flange Seal and Bolt Kit: PTFE(or Grafoil) sealing rings + 7/16-20UNF Bolts

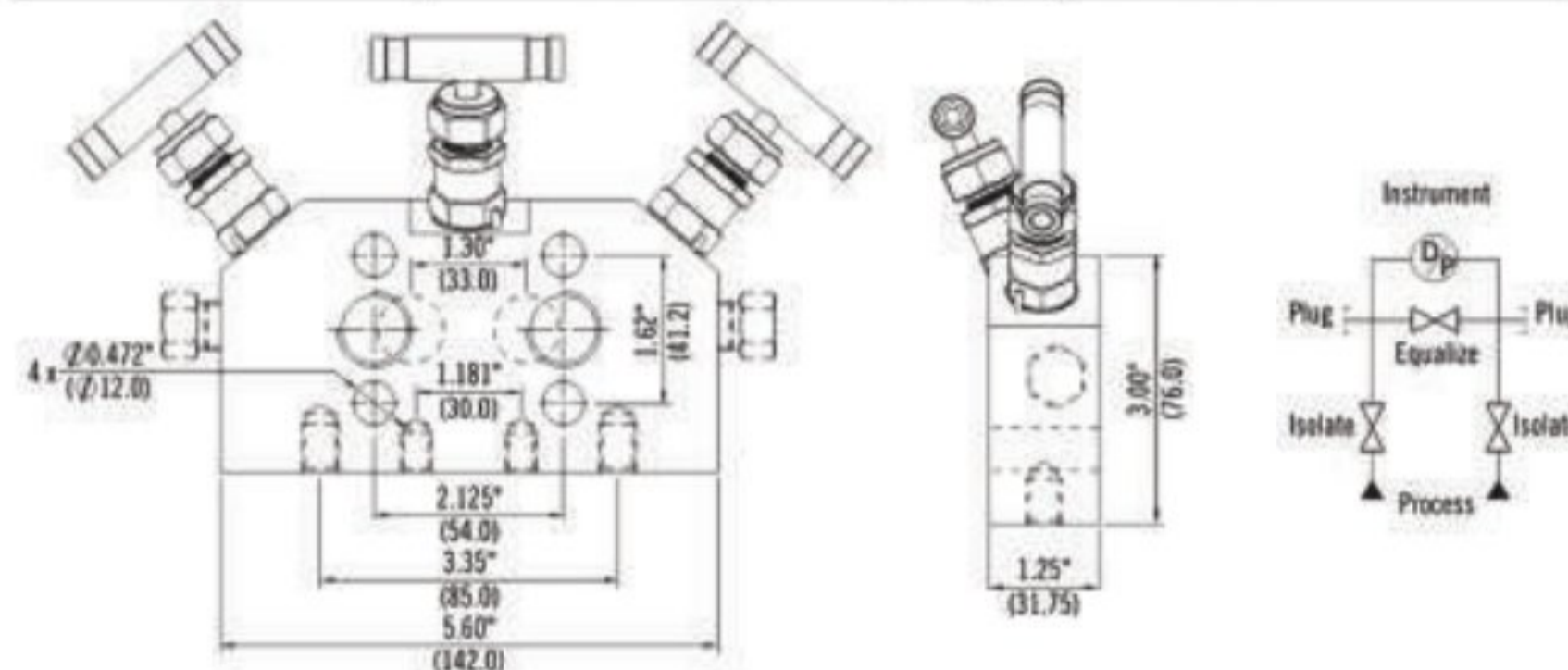

Basic Model Number	Inlet / process	Outlet / instrument	Test / vent
-3R-F8-V	1/2" Female NPT	1/2" Female NPT	Optional
-3R-S8-V	1/2" C-LOK	1/2" C-LOK	Optional

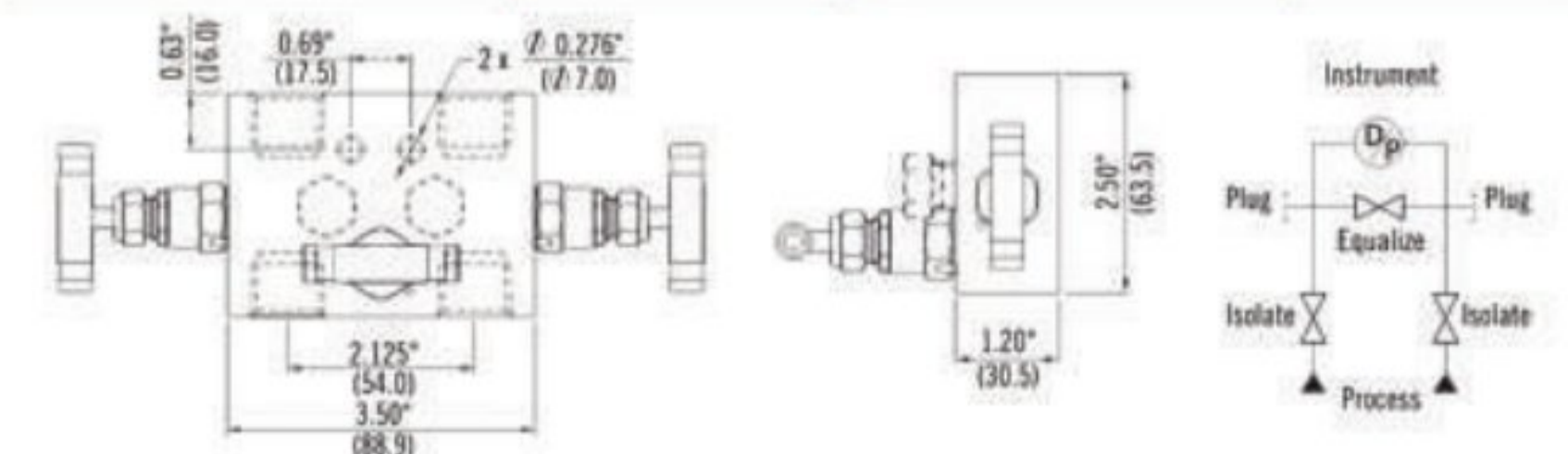

Five -Valves Manifolds

5D

Features

- Five valves in one block for isolation, equalization, testing and venting of instruments

Basic Model Number	Inlet / process	Outlet / instrument	Test / vent
-5D-F8-A	1/2" Female NPT	Flange(MSS)	1/4" Female NPT

Flange Seal and Bolt Kit: PTFE(or Grafoil) sealing rings + 7/16-20UNF Bolts

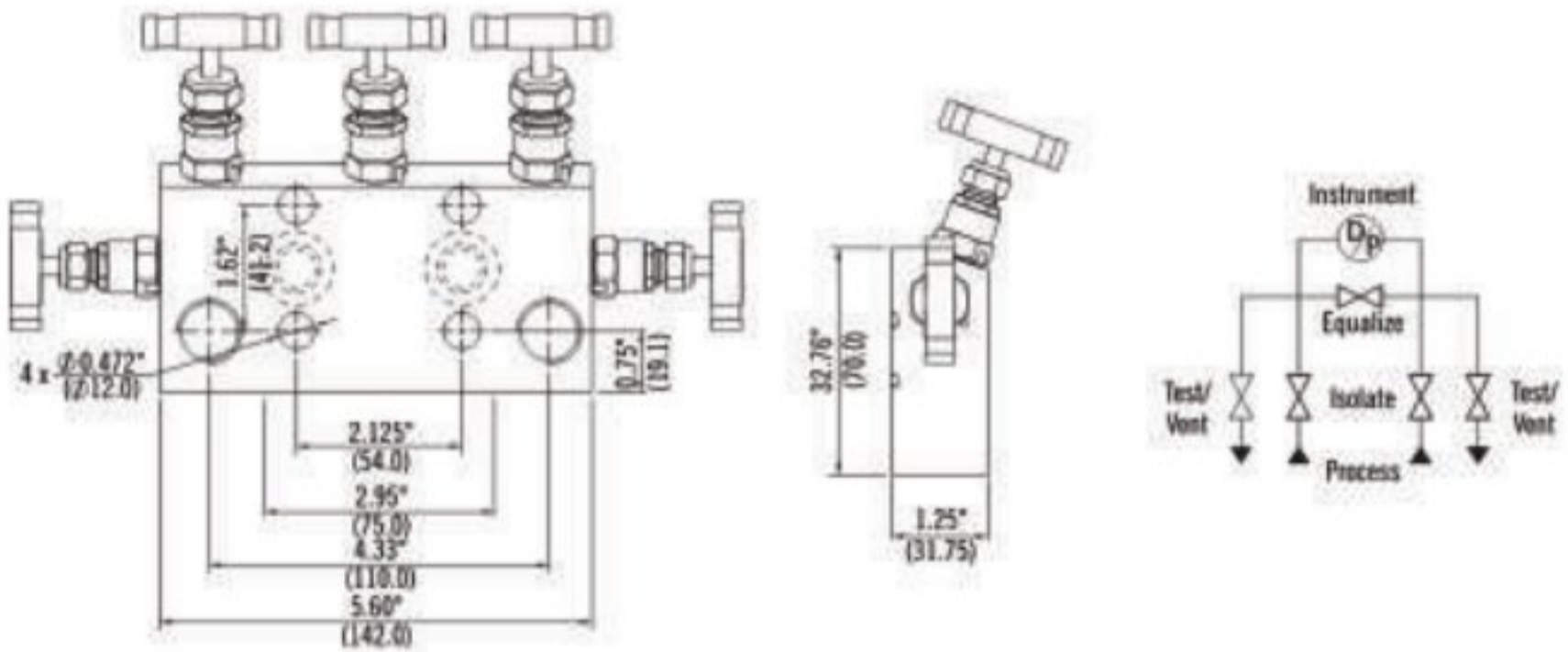

Basic Model Number	Inlet / process	Outlet / instrument	Test / vent
-5D-F8-C	1/2" Female NPT	Flange(MSS)	1/4" Female NPT
-5D-S8-C	1/2" C-LOK	Flange(MSS)	1/4" Female NPT

Flange Seal and Bolt Kit: PTFE(or Grafoil) sealing rings + 7/16-20UNF Bolts

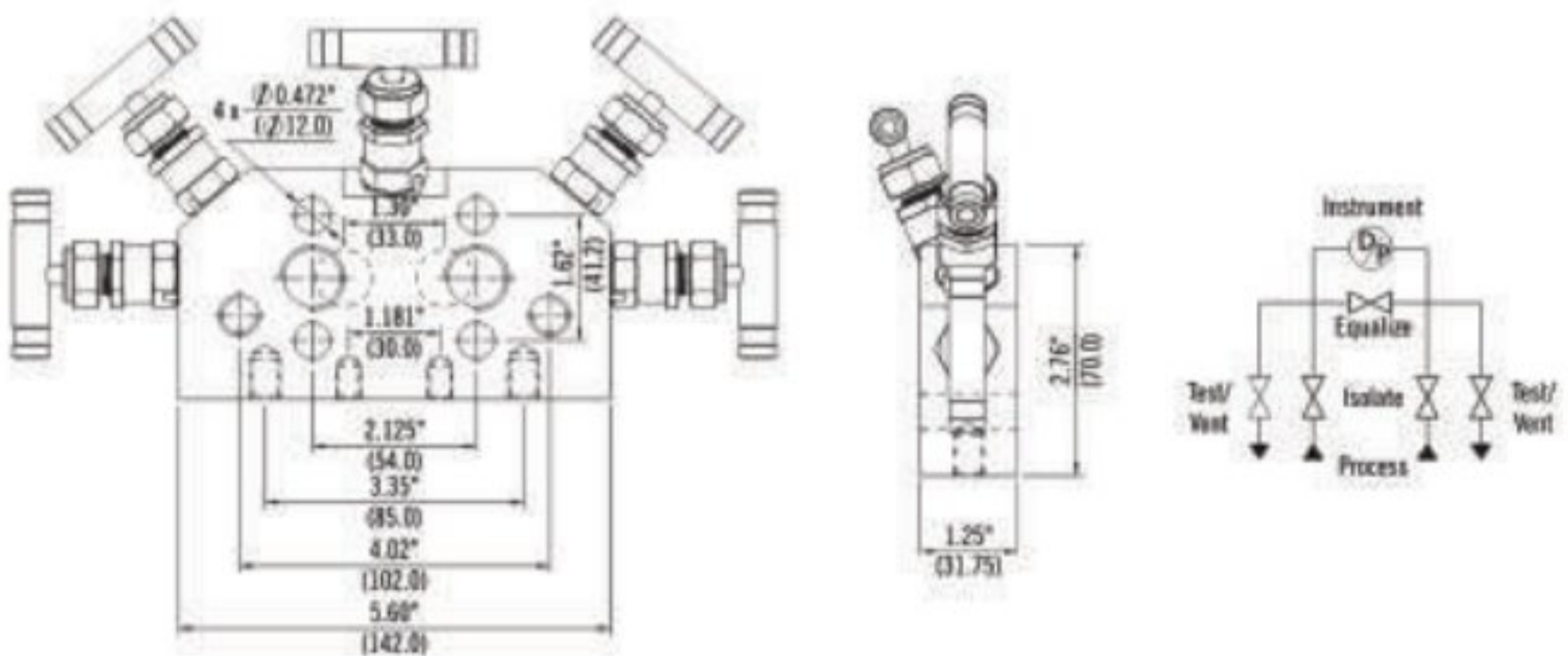

C-LOK

Instrument Valve Co., Ltd.

C-LOK the high quality instrumentation valves & fittings specialized production manufacture

Five -Valves Manifolds

5D

Features

Basic Model Number	Inlet / process	Outlet / instrument	vent	Test
-5D-F8-B	1/2" Female NPT	Flange(MSS)	1/4" Female NPT	Option
-5D-S8-B	1/2" C-LOK	Flange(MSS)	1/4" Female NPT	Option

Flange Seal and Bolt Kit: PTFE(or Grafoil) sealing rings + 7/16-20UNF Bolts

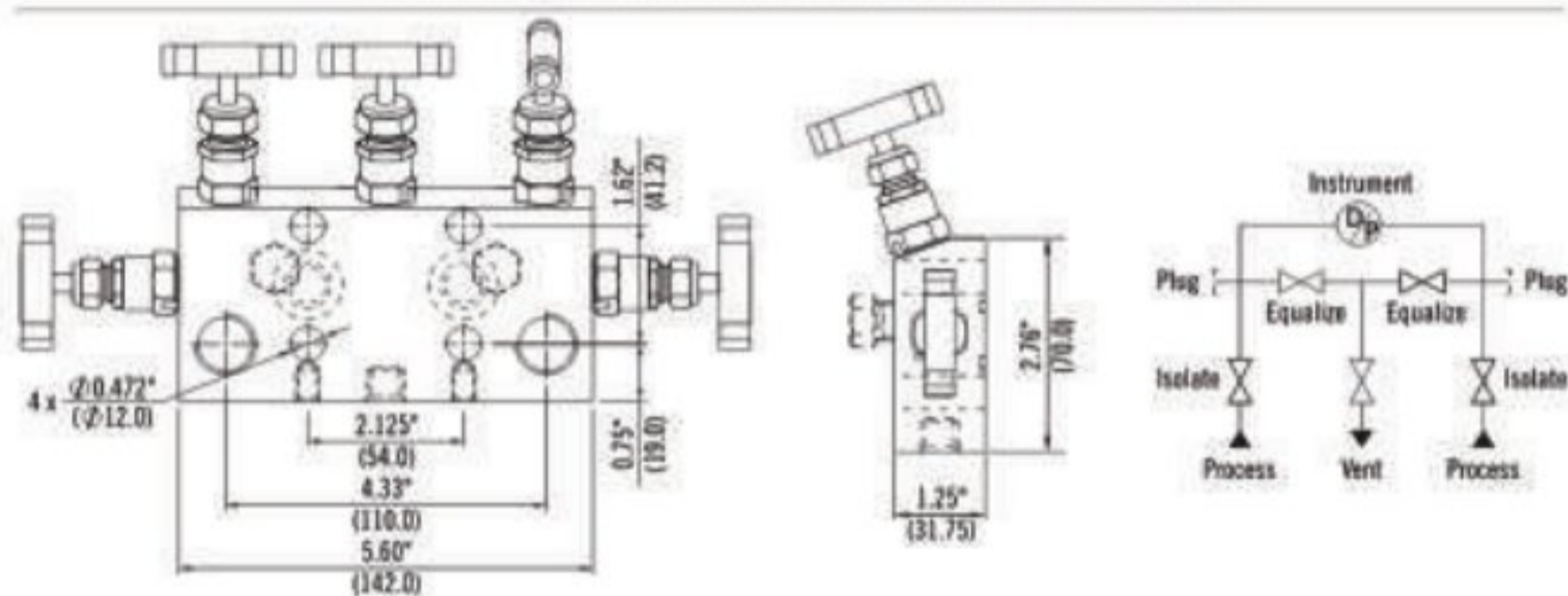

Basic Model Number	Inlet / process	Outlet / instrument	Test / vent
-5R-F8-A	1/2" Female NPT	1/2" Female NPT	1/4" Female NPT

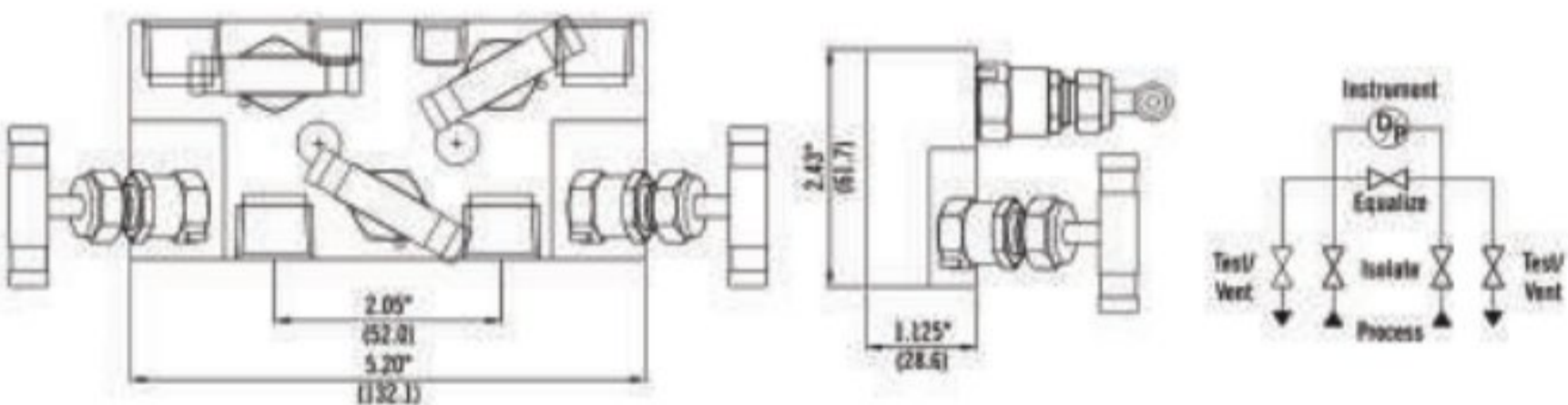

Basic Model Number	Inlet / process	Outlet / instrument	Test / vent
-5R-F8-L	1/2" Female NPT	1/2" Female NPT	1/4" Female NPT
-5R-S8-L	1/2" C-LOK	1/2" Female NPT	1/4" Female NPT

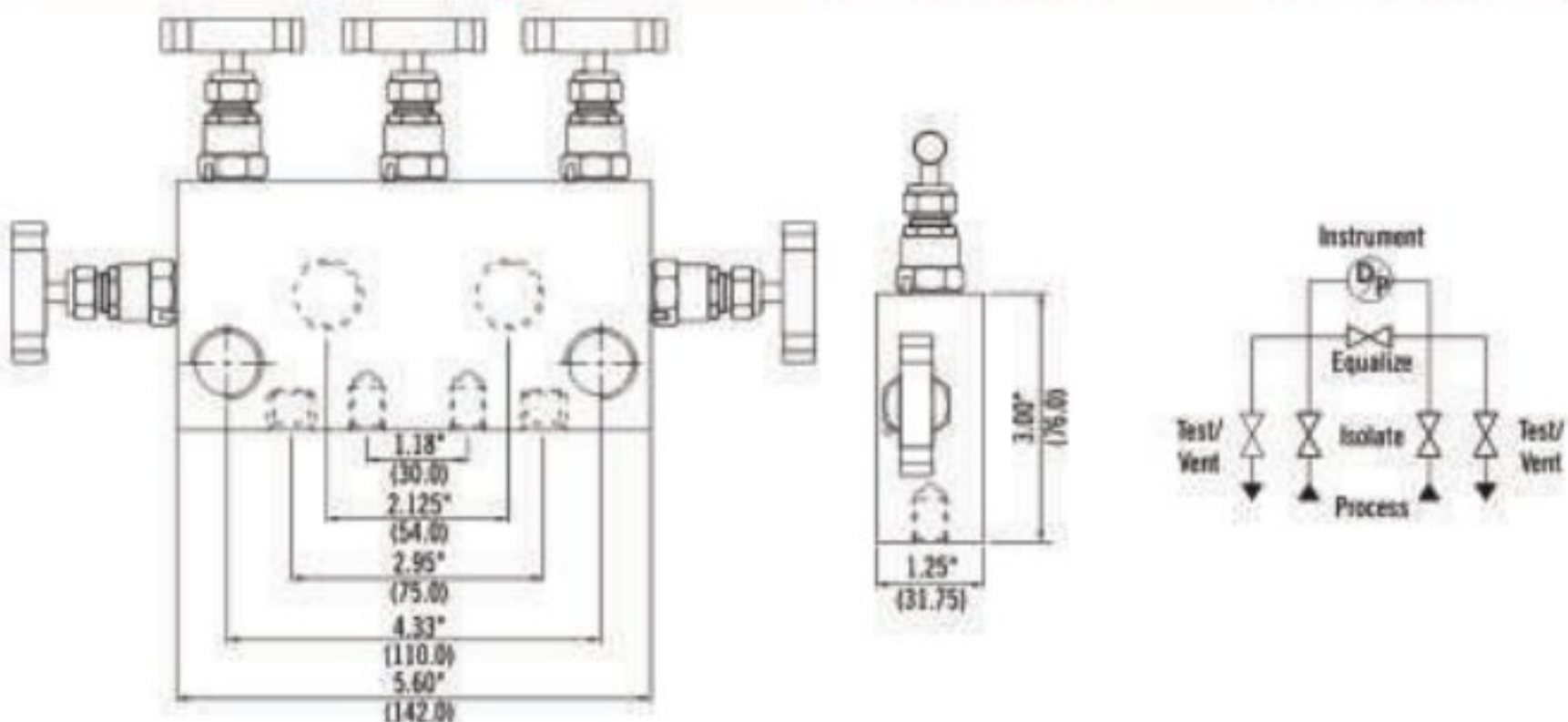

C-LOK

Instrument Valve Co., Ltd.

C-LOK the high quality instrumentation valves & fittings specialized production manufacture

Gauge Valves

GV

Features

- A valve with 3 outlets in one block for isolation, bleeding of instruments.

Basic Model Number	Inlet / process	Outlet / instrument	Test / vent
-GV-M8-F8	1/2" Male NPT	1/2" Female NPT	1/2" Female NPT

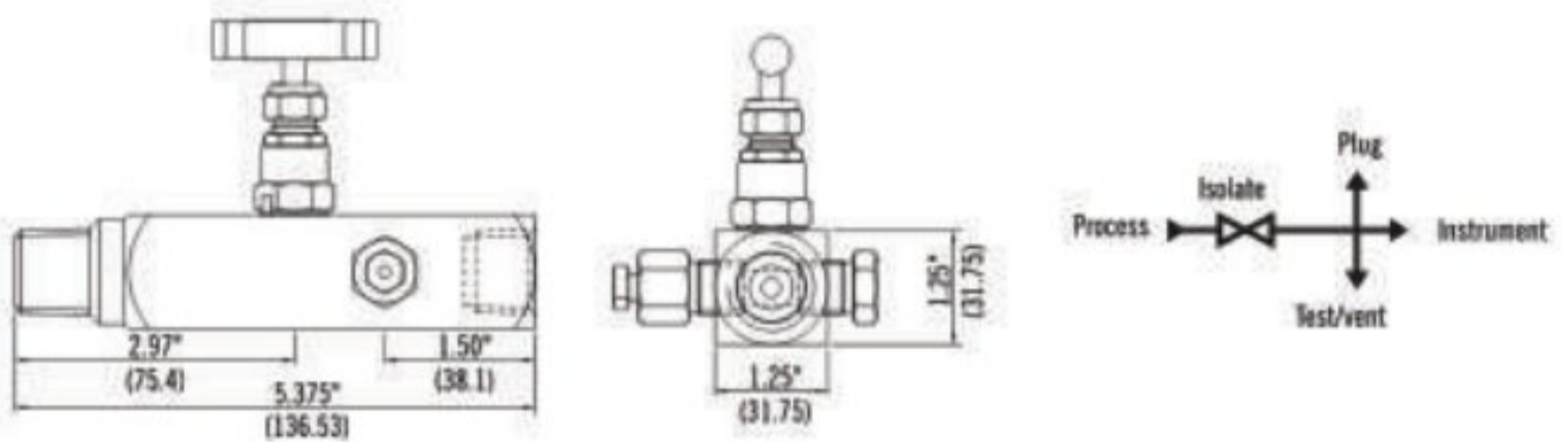

Basic Model Number	Inlet / process	Outlet / instrument	Test / vent
-GV-M8-F8-E	1/2" Male NPT	1/2" Female NPT	1/2" Female NPT

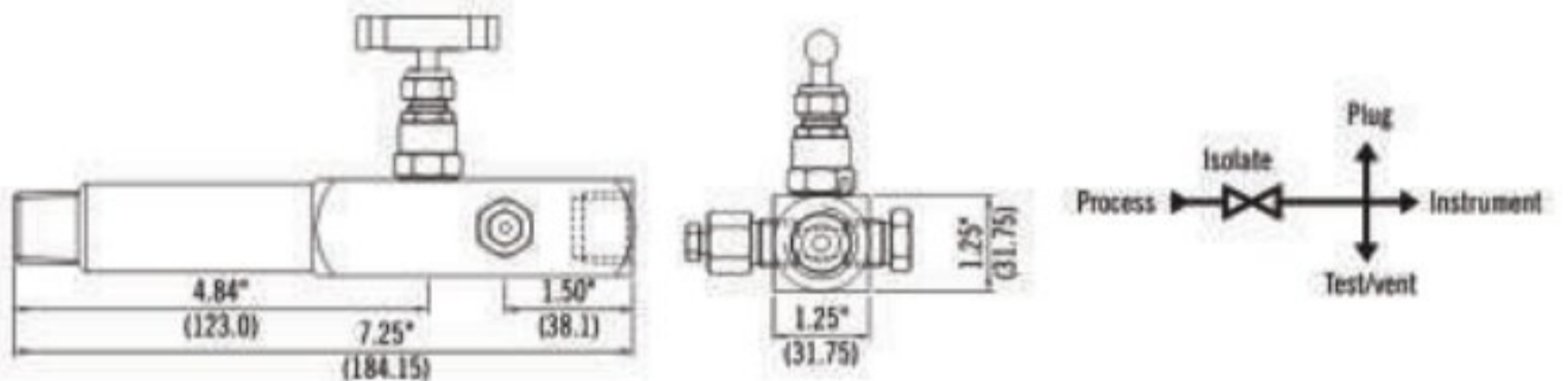

Basic Model Number	Inlet / process	Outlet / instrument
-GV-M8-F8-C	1/2" Male NPT	1/2" Female NPT

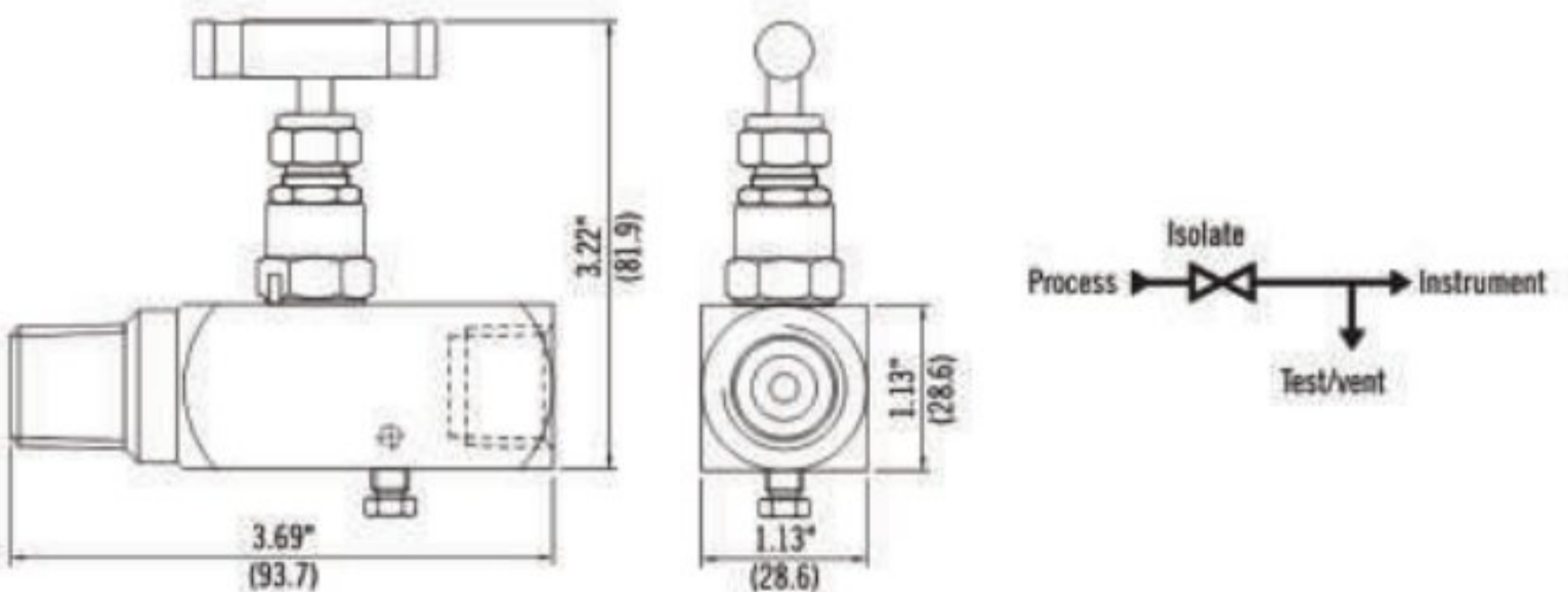



CHECK VALVE



C-LOK the high quality
instrumentation valves
& fittings specialized
production manufacture

C-LOK

Instrument Valve Co., Ltd.

C-LOK the high quality instrumentation valves & fittings specialized production manufacture

Check Valves

C

Features

Reliable prevent back flow function and high Cv flow rate:

C1, C2, and C3 Series

Fixed cracking pressures Can be install in any directions

C1 Series

- resilient O-ring seat design provides cushioned and noise-free closing, and resists flow-out
- Maximum working pressure: 3000 psig (207 bar)
- Working temperatures: -10°F to 375°F (-23°C to 190°C)
- Cracking pressures: 1/3 to 25 psig (0.02 to 1.7 bar)
- Various end connections and many materials of construction

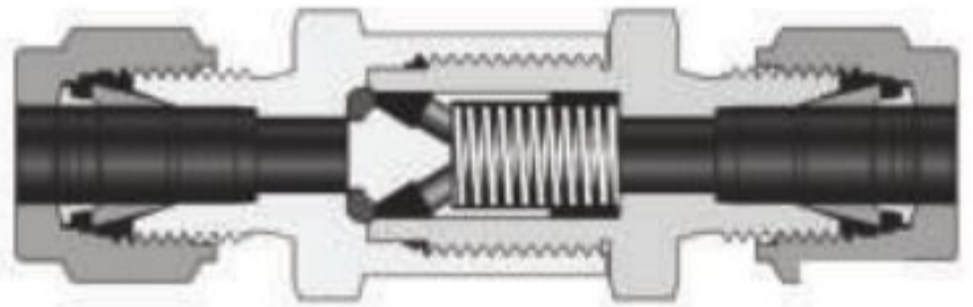

C2 Series

- The floating O-ring is cleaned continually to protect sealing from system contaminants
- Maximum working pressure: 6000 psig (414 bar)
- Working temperatures: -10°F to 400°F (-23°C to 204°C)
- Cracking pressures: 1/3 to 25 psig (0.02 to 1.7 bar)
- Various end connections and many materials of construction

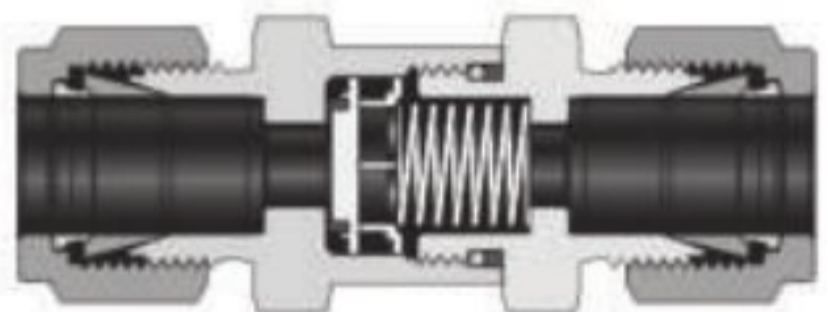

C3 Series

- Compact, one piece body
- Maximum working pressure: 3000 psig (207 bar)
- Working temperature: -10°F to 375°F (-23°C to 190°C)
- Cracking pressures: 1/3 to 25 psig (0.02 to 1.7 bar)
- Various end connections and many materials of construction

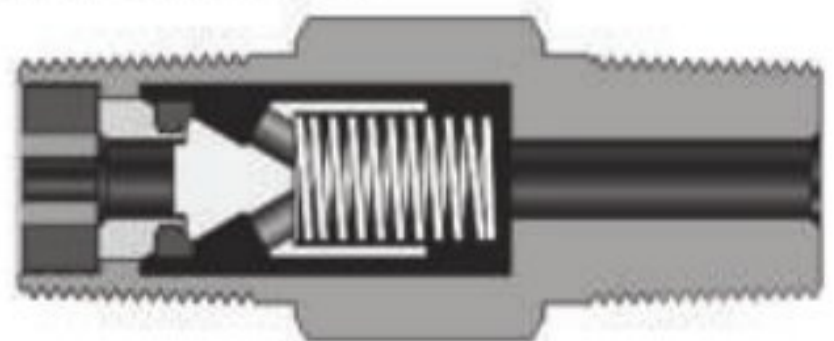

C-LOK

Instrument Valve Co., Ltd.

C-LOK the high quality instrumentation valves & fittings specialized production manufacture

Check Valves

C

Features

C4 and C5 series

Adjustable Cracking pressures various optional springs install in any directions

C4 Series

- Maximum working pressure: 3000 psig(207 bar)
- Working temperatures:-10°F to 375°F (-23°C to 190°C)
- Cracking pressures:3 to 600 psig(0.2 to 41.3 bar)
- Various end connections and many materials of construction

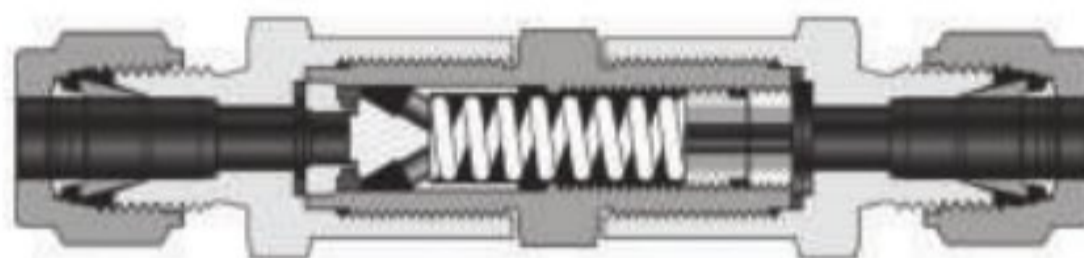

C5 Series

- Compact, one piece body
- Maximum working pressure: 3000 psig(207 bar)
- Working temperatures:-10°F to 400°F (-23°C to 204°C)
- Cracking pressures:3 to 600 psig (0.2 to 41.3 bar)
- Various end connections and many materials of construction

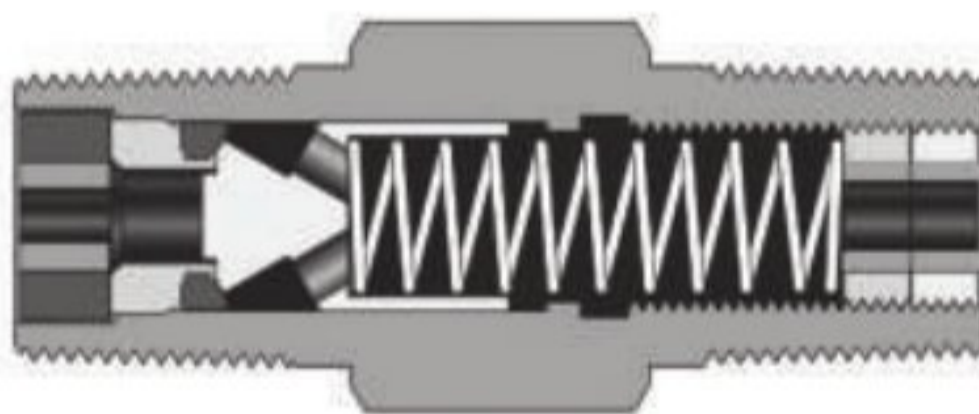

C6 series

Union bonnet design All-stainless steel structure Horizontal installation

- Maximum working pressure:6000 psig (414 bar)
- Working temperatures:-65°F to 900°F (-53°C to 482°C)
- Many options for various end connections
- Provide 316 SS valve body and brass valve body

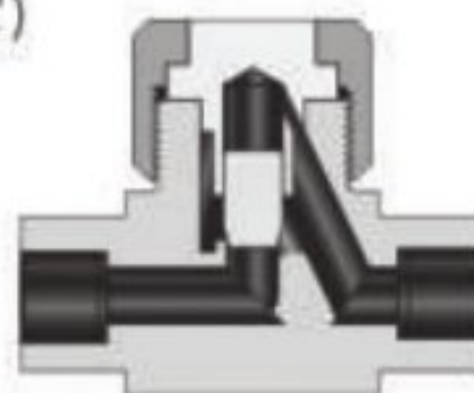

C-LOK

Instrument Valve Co., Ltd.

C-LOK the high quality instrumentation valves & fittings specialized production manufacture

Check Valves

C

Cracking Pressure and Resealed Pressure

Series	Nominal Cracking Pressures psig (bar)	Cracking pressures range psig (bar)	Reseal pressure range psig (bar)
C1 Series	1/3 (0.02) 1 (0.06) 10 (0.68) 25 (1.7)	1/3-3 (0.02-0.2) 1-4 (0.06-0.27) 7-15 (0.48-1.0) 20-30 (1.3-2.0)	Max 6(0.41) Max 6(0.41) 3(0.2) or higher 17(1.1) or higher
C2 Series	1/3 (0.02) 1 (0.06) 5 (0.34) 10 (0.68) 25 (1.7)	1/3-3 (0.02-0.2) 1-4 (0.06-0.27) 3-9 (0.20-0.62) 7-15 (0.48-1.0) 20-30 (1.3-2.0)	Max 6(0.41) Max 2(0.13) 3(0.2) or higher 17(1.1) or higher
C3 Series	1/3 (0.02) 1 (0.06) 10 (0.68) 25 (1.7)	1/3-3 (0.02-0.2) 1-4 (0.06-0.27) 7-15 (0.48-1.0) 20-30 (1.3-2.0)	Max 6(0.41) Max 6(0.41) 3(0.2) or higher 17(1.1) or higher
C4 Series	3-50 (0.2-3.4)	-	shown in figure below
C5 Series	50-150 (3.4-10.3) 150-350 (10.3-24.1) 350-600 (24.1-41.3)		
C6 Series	1/3 (0.02) 1 (0.06)	1/3-1/2 (0.02-0.03) 1-4 (0.06-0.27)	Max 6(0.41) Max 5(0.34)

Check Valves

C

Pressure VS. Temperature

C1, C3, C4, C5 Series

FKM seat in 316 SS body and buna N in brass body

Temperature		Valve body material	
		316 SS	Brass
°F	°C	Working pressure, psig (bar)	
-10~100	-23~37	3000(207)	3000(207)
200f	93	2575(177)	2600(179)
250	121	2450(168)	2405(165)
300	148	2325(160)	—
375	190	2185(150)	—

C2 Series

FKM seat in 316 SS body

Temperature		Valve body material
		316 SS
°F	°C	Working pressure, psig (bar)
-10~100	-23~37	6000(414)
200	93	5160(355)
250	121	4910(338)
300	148	4660(321)
375	190	4280(294)

Note: Consult the factory for the curves of other materials.

C-LOK

Instrument Valve Co., Ltd.

C-LOK the high quality instrumentation valves & fittings specialized production manufacture

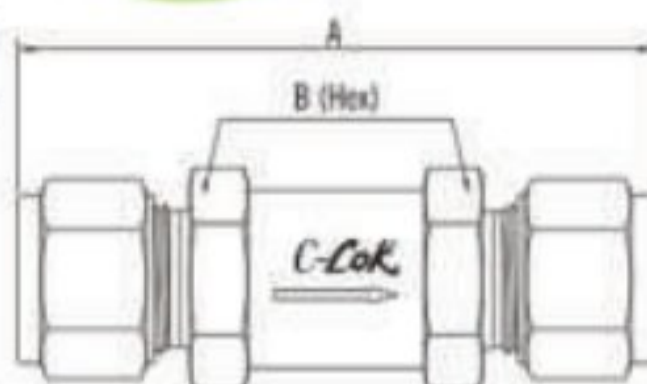

Check Valves

C² series

Pressure VS. Temperature

Basic Ordering Number	Connection Size		Pressure Rating at 100(37°C) psig(bar)	CV
	Inlet Size	Outlet Size		
-C2-S2-	1/8" C-LOK	1/8" C-LOK	6000(414)	0.67
-C2-S4-	1/4" C-LOK	1/4" C-LOK	6000(414)	0.67
-C2-S6-	3/8" C-LOK	3/8" C-LOK	6000(414)	1.8
-C2-S8-	1/2" C-LOK	1/2" C-LOK	6000(414)	1.8
-C2-S12-	3/4" C-LOK	3/4" C-LOK	5000(344)	4.7
-C2-S16-	1" C-LOK	1" C-LOK	4700(323)	4.7
-C2-SM6-	6mm C-LOK	6mm C-LOK	6000(414)	0.67
-C2-SM8-	8mm C-LOK	8mm C-LOK	6000(414)	1.8
-C2-SM10-	10mm C-LOK	10mm C-LOK	6000(414)	1.8
-C2-SM12-	12mm C-LOK	12mm C-LOK	6000(414)	1.8
-C2-SM22-	22mm C-LOK	22mm C-LOK	5000(344)	4.7
-C2-SM25-	25mm C-LOK	25mm C-LOK	5000(344)	4.7
-C2-F4-	1/4 Female NPT	1/4 Female NPT	6000(414)	0.67
-C2-F6-	3/8 Female NPT	3/8 Female NPT	5000(344)	1.8
-C2-F8-	1/2 Female NPT	1/2 Female NPT	4600(316)	1.8
-C2-F12-	3/4 Female NPT	3/4 Female NPT	4300(296)	4.7
-C2-F16-	1 Female NPT	1 Female NPT	4100(282)	4.7
-C2-M2-	1/8 Male NPT	1/8 Male NPT	6000(414)	0.67
-C2-M4-	1/4 Male NPT	1/4 Male NPT	6000(414)	0.67
-C2-M6-	3/8 Male NPT	3/8 Male NPT	6000(414)	1.8
-C2-M8-	1/2 Male NPT	1/2 Male NPT	6000(414)	1.8
-C2-M12-	3/4 Male NPT	3/4 Male NPT	5000(344)	4.7
-C2-M16-	1 Male NPT	1 Male NPT	5000(344)	4.7
-C2-FR4-	1/4 Female BSPT	1/4 Female BSPT	6000(414)	0.67
-C2-FR8-	1/2 Female BSPT	1/2 Female BSPT	4600(316)	1.8
-C2-FR12-	3/4 Female BSPT	3/4 Female BSPT	4300(296)	4.7
-C2-FR16-	1 Female BSPT	1 Female BSPT	4100(282)	4.7
-C2-MR4-	1/4 Male BSPT	1/4 Male BSPT	6000(414)	0.67
-C2-MR8-	1/2 Male BSPT	1/2 Male BSPT	6000(414)	1.8
-C2-MR12-	3/4 Male BSPT	3/4 Male BSPT	5000(344)	4.7
-C2-MR16-	1" Male BSPT	1" Male BSPT	5000(344)	4.7



C-LOK

Instrument Valve Co., Ltd.

C-LOK the high quality instrumentation valves
& fittings specialized production manufacture

Check Valves

C

Cracking Pressure and Resealed Pressure

C6 Series
316 SS body

Temperature		Valve body material
		316 SS
°F	°C	Working pressure, psig (bar)
-65~100	-53~37	6000(414)
200	93	5160(356)
250	121	4910(338)
300	148	4660(321)
350	176	4470(307)
400	204	4280(295)
450	232	4130(285)
500	260	3980(274)
600f	315	3760(259)
650	343	3690(254)
700	371	3600(248)
750	399	3510(242)
800	426	3460(238)
850	454	3380(232)
900	482	3280(225)



Check Valves

C

Material of Constraction

C1 Series

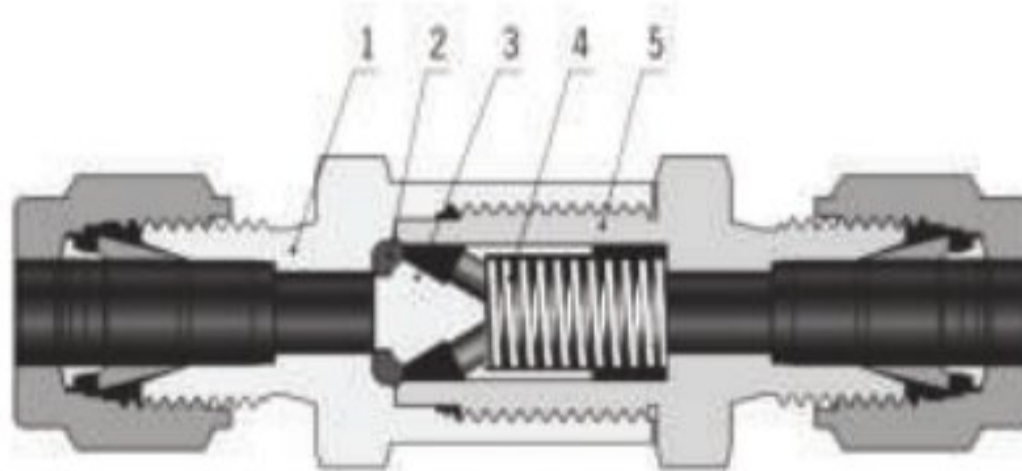

Component		Valve Material Grade/ASTM Specification	
		316 SS	Brass
1	Inlet body	316 SS/A479	Brass 360/B16
2	O-ring	Fluorocarbon FKM	Buna N
3	Poppet	316 SS/A479	Brass 360/B16
4	Spring	302 SS/A313	302 SS/A313
5	Outlet body	316 SS/A479	Brass 360/B16

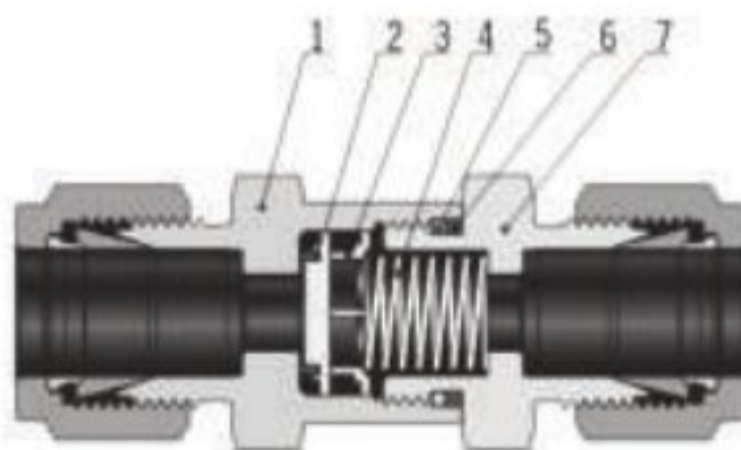

C2 Series

Component	Valve Material Grade/ASTM Specification	
1	Inlet body	316 SS/A479
2	Poppet	Fluorocarbon FKM -bonded 316 SS/A479
3	Poppet stop	316 SS/A240
4	Spring	302 SS/A313
5	O-ring	Fluorocarbon FKM
6	Backup ring	PTFE/D1710
7	Outlet body	316 SS/A479

Check Valves

C

Cracking Pressure and Resealed Pressure

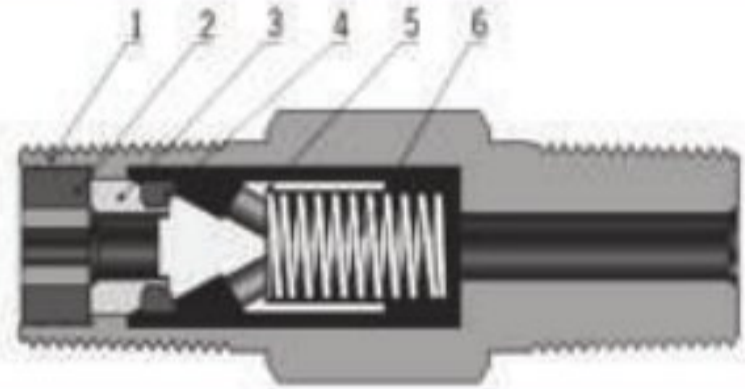

C3 Series

Component		Valve Material Grade/ASTM Specification	
		316 SS	Brass
1	Body	316 SS/A276 or A479	Brass 360/B16
2	Locking screw	316 SS/A276	Brass 360/B16
3	Insert	316 SS/A276	Brass 360/B16
4	O-ring	Fluorocarbon FKM	Buna N
5	Poppet	316 SS/A479	Brass 360/B16
6	Spring	302 SS/A313	302 SS/A313

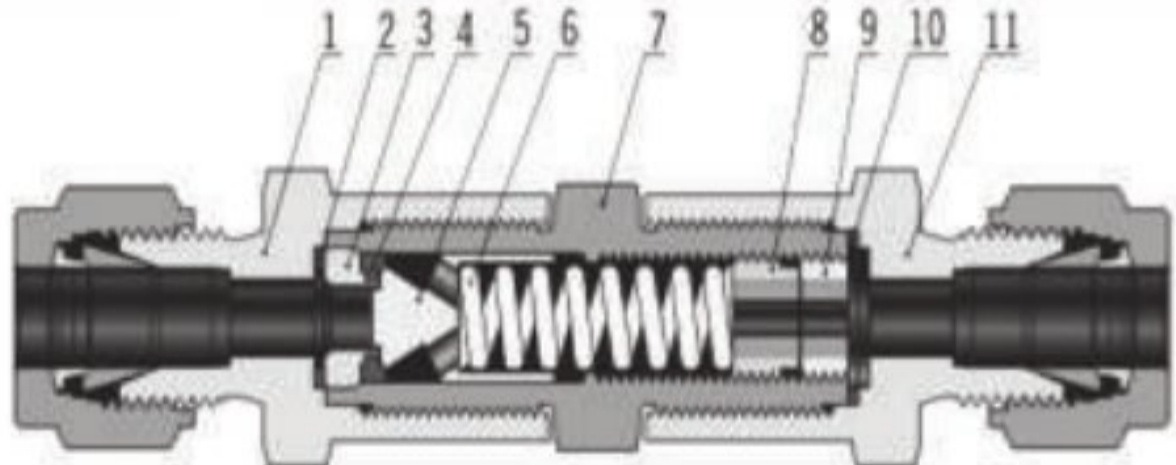

C4 Series

Component		Valve Material Grade/ASTM Specification	
		316 SS	Brass
1	Inlet body	316 SS/A479	Brass 360/B16
2	Inlet gasket	PTFE-coated 316 SS/A276	PTFE-coated 316 SS/A276
3	Insert	316 SS/A479	Naval brass 360/B21
4	O-ring	Fluorocarbon FKM	Fluorocarbon FKM
5	Poppet	316 SS/A479	Brass 360/B16
6	Spring	302 SS/A313	302 SS/A313
7	Center body	316 SS/A479	Brass 360/B16
8	Adjusting screw	316 SS/A276	316 SS/A276
9	Locking nut	316 SS/A276	316 SS/A276
10	Outlet gasket	PTFE-coated 316 SS/A276	PTFE-coated 316 SS/A276
11	Outlet body	316 SS/A479	Brass 360/B16

Check Valves

C

Material of Construction

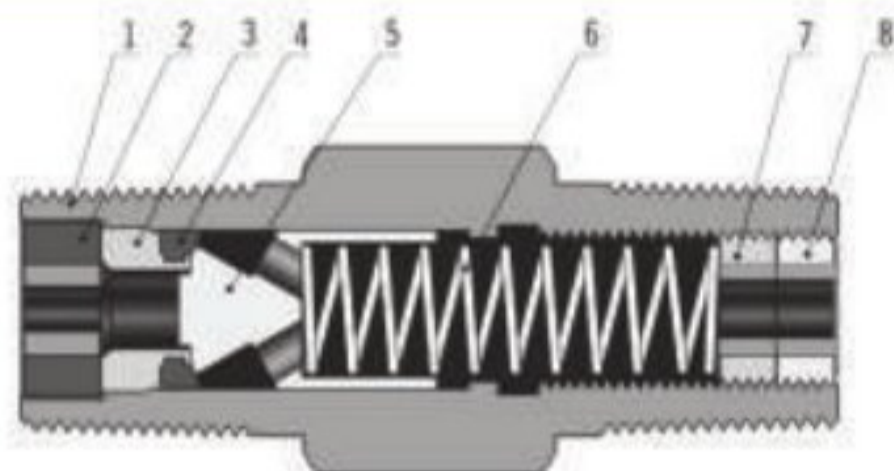

C5 Series

Component	Valve Material Grade/ASTM Specification		
	316 SS	Brass	
1	Body	316 SS/A276	Brass 360/B16
2	Locking Nut	316 SS/A479	Brass 360/B16
3	Insert	316 SS/A479	Brass 360/B16
4	O-ring	Fluorocarbon FKM	Fluorocarbon FKM
5	Poppet	316 SS/A479	Brass 360/B16
6	Spring	302 SS/A313	302 SS/A313
7	Adjusting screw	316 SS/A276	316 SS/A276
8	Locking screw	316 SS/A276	316 SS/A276

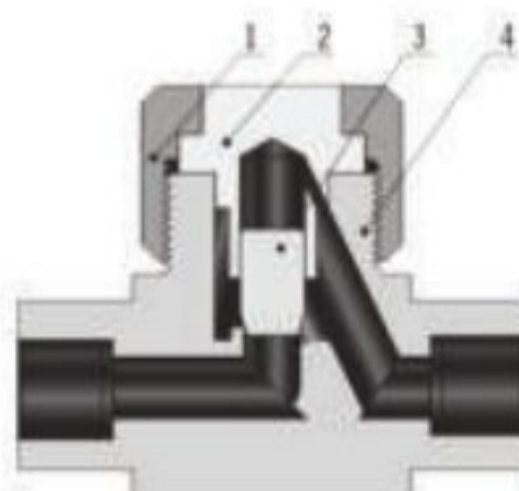

C6 Series

Component	Valve Material Grade/ASTM Specification	
1	Bonnet nut	316 SS/A479
2	Bonnet	316 SS/A479
3	Poppet	S17400/A564
4	Body	316 SS/A479

*All valves use same lubricants, they are silicone-based and molybdenum disulfide-based.
 *Consult the factory for bill of material for other body materials.



C-LOK

Instrument Valve Co., Ltd.



RELIEF VALVES



C-LOK the high quality instrumentation valves & fittings specialized production manufacture

C-LOK

Instrument Valve Co., Ltd.

C-LOK the high quality instrumentation valves & fittings specialized production manufacture

Relief Valves

R1

Introduction

Valves open when system pressure reaches the set pressure. Then the medium flow out to release system pressure. Valves close when the system pressure is lower than the set pressure.

The opening height and the system pressure are direct proportional. However, there's no limit for relieving capacity. So valves in this series should be selected carefully according to system requirements.



Features

- Set pressure: 50 to 6000 psig @70°F (0.34 to 41.4 Mpa @21°C)
- Maximum outlet pressure: 1500 psig (103 bar)
- Working temperatures: -10°F to 300°F (-23°C to 148°C)
- many options for various end connections
- Liquid or gas service
- Adjustable bonnet cap, and adjustable set pressure
- Balance stem design to eliminate the effect of system back pressure
- 7 color-coded springs available for a wide range of set pressure
- Lock wired secure cap to maintain set pressure
- Many options for various seal materials
- Label identifies the set pressure range
- Manual override handle available to open the valve without changing the set pressure when lower than 1500 psig

Cracking Pressure and Resealing Pressure

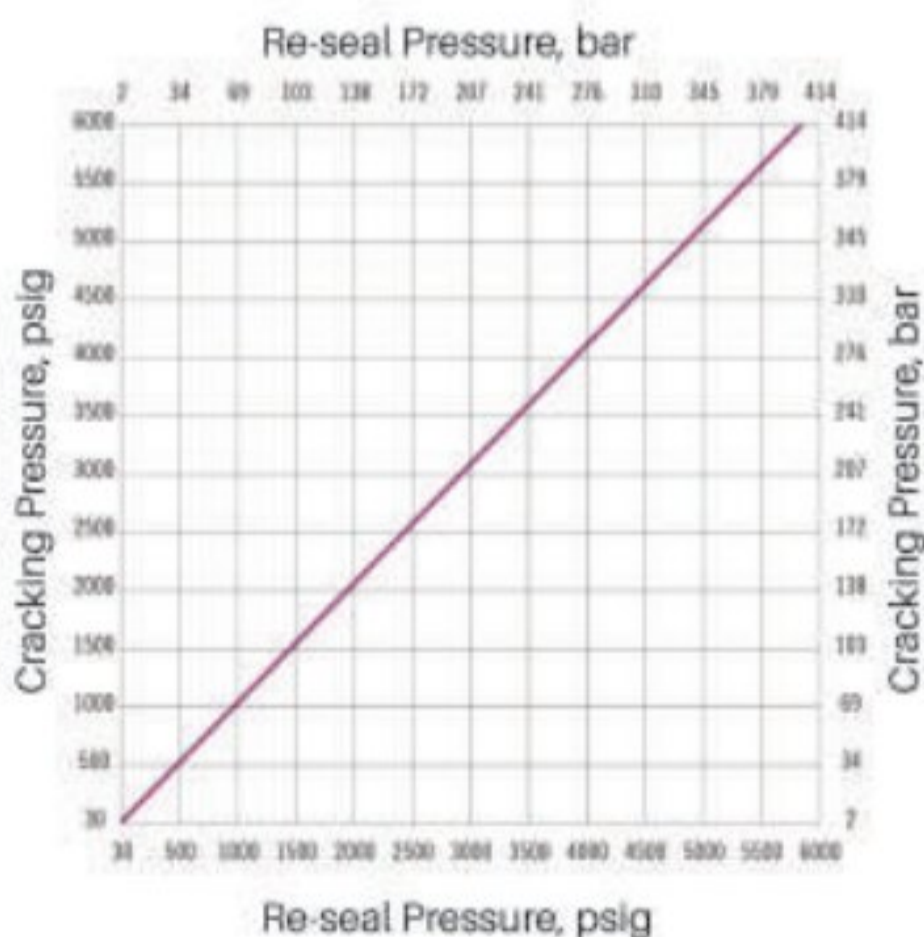

Cracking Pressure: The pressure at which the first indication of flow occurs. The repeatability of the cracking pressure of each valve after initial relief is within + 5% at room temperature.

Resealing Pressure: The pressure at which there is no indication of flow. Resealing pressure is always lower than set pressure.

Back Pressure: The pressure of the outlet of the valve. It increases the set pressure.



Relief Valves

R1

Material of Constraction

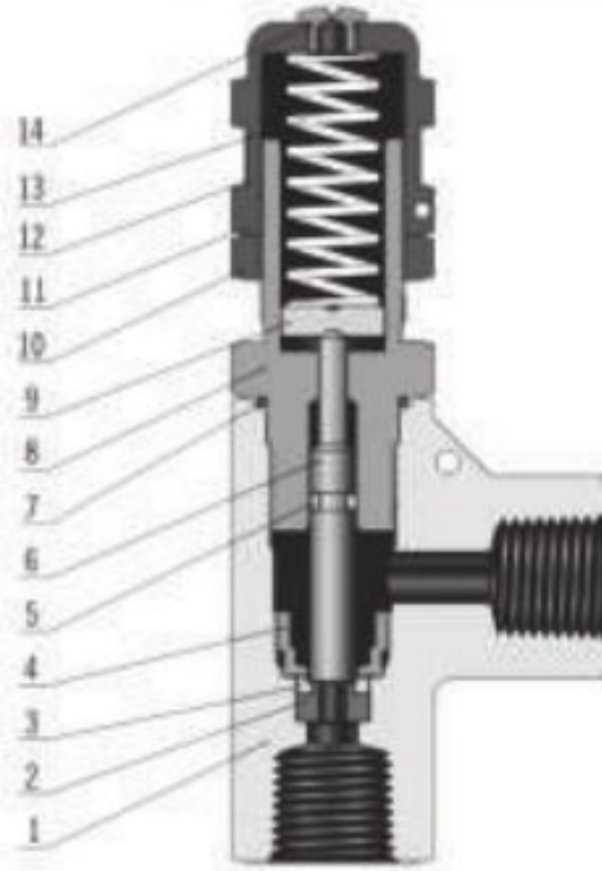

Component	Material Grade/ASTM Specification	
1	Body	316 SS/A182
2	Insert	316 SS/A479
3	O-ring	Fluorocarbon FKM
4	Seat retainer	316 SS/A479
5	o-ring	Fluorocarbon FKM
6	Stem	316 SS/A479
7	o-ring	Fluorocarbon FKM
8	Bonnet	316 SS/A479
9	Spring support	316 SS/A276
10	Lock nut	17-4PH powered metal
11	Bonnet cap	316 SS/A479
12	Label	Polyester
13	Spring	S17700 SS/AMS 5678
14	Cap	316 SS/A276

*Lubricant: Molybdenum disulfide-based dry film and paste, silicone-based.

*Consult the factory for bill of material for other body materials.

C-LOK

Instrument Valve Co., Ltd.

C-LOK the high quality instrumentation valves
& fittings specialized production manufacture

Relief Valves

R1

Spring Kits

Spring Designator	Spring Color	Set Pressure Rang psig (bar)	Remark
F	Green	50~300 (3.4~20.7)	For 0.14 in. and 0.25 in. orifice size
O	Orange	300~700 (20.7~48.3)	
Y	Yellow	700~1500 (48.3~103)	
P	Purple	1500~2500 (103~172)	For 0.14in. orifice size only
W	White	2500~3500 (172~241)	
J	Blue	3500~4500 (241~310)	
C	Red	4500~6000 (310~414)	



C-LOK

Instrument Valve Co., Ltd.



FITLERS



C-LOK the high quality
instrumentation valves
& fittings specialized
production manufacture

Filters

F1, F2, F3 and F4 Series

Filtration Definitions

1. Sintered element: metal powder(alloys are available) is pressed in a die at sufficient pressure that the powder particles adhere at their contact points;
2. Strainer element: the strainer is cup-shaped and includes an inner cup-shaped support structure having staggered perforations extending through the surfaces thereof,an outer cup-shaped strainer structure of wire mesh is closely received over the support structure;
3. Element nominal pore size: the element nominal pore size is normally calculated from the pressure required to cause air to bubble from the largest pore in the filter element when submerged in a test liquid.

Features

Tee-type filters

F1 Series

1. Filter element replaceable without removing body from system;
2. Union bonnet design;
3. Nominal pore sizes for sintered element: 0.5, 2, 7, 15, 40, 60 and 80 um;
4. Nominal pore sizes for sintered element: 100, 150, 250 and 450 um;
5. Maximum working pressure: 6000 psig (414 bar);
6. Working temperature:-20°F to 900°F (-29°C to 482°C);
7. Body materials: 316 SS, 316L SS, 304 SS, 304L SS and Brass;
8. Variety of end connections available.

Bypass Filters

F2 Series

1. Bypass port at filter bottom for the ease of sampling purging;
2. Union bonnet design;
3. Nominal pore sizes for sintered element: 0.5, 2, 7, 15, 40, 60 and 80 um;
4. Nominal pore sizes for sintered element: 100, 150, 250 and 450 um;
5. Maximum working pressure: 6000 psig (414 bar);
6. Working temperature:-20°F to 900°F (-29°C to 482°C);
7. Body materials: 316 SS, 316L SS, 304 SS, 304L SS and Brass;
8. Variety of end connections available.

In-line Filters

F3 Series

1. Compact and space-saving design;
2. Nominal pore sizes for sintered element: 0.5, 2, 7, 15, 40, 60 and 80 um;
4. Nominal pore sizes for sintered element: 100, 150, 250 and 450 um;
5. Maximum working pressure: 3000 psig (207 bar);
6. Working temperature:-20°F to 900°F (-29°C to 482°C);
7. Body materials: 316 SS, 316L SS, 304 SS, 304L SS and Brass;
8. Variety of end connections available.

C-LOK

Instrument Valve Co., Ltd.

C-LOK the high quality instrumentation valves & fittings specialized production manufacture

Filters

F1, F2, F3 and F4 Series

All-welded In-line Filters

F4 Series

1. Large filtration area and high flow coefficient;
2. All-welded construction for elimination of leakage;
3. Easy cleaning of filters by backflushing;
4. Full-penetration weld between body and element;
5. Nominal pore sizes for sintered element: 0.5, 2, 7, 15, 40, 60 and 80 μm ;
6. Maximum working pressure: 6000 psig (414 bar);
7. Working temperature: -20°F to 900°F (-29°C to 482°C);
8. Body materials: 316 SS, 316L SS, 304 SS, 304L SS and Brass;
9. Variety of end connections available.

Pressure VS. temperature

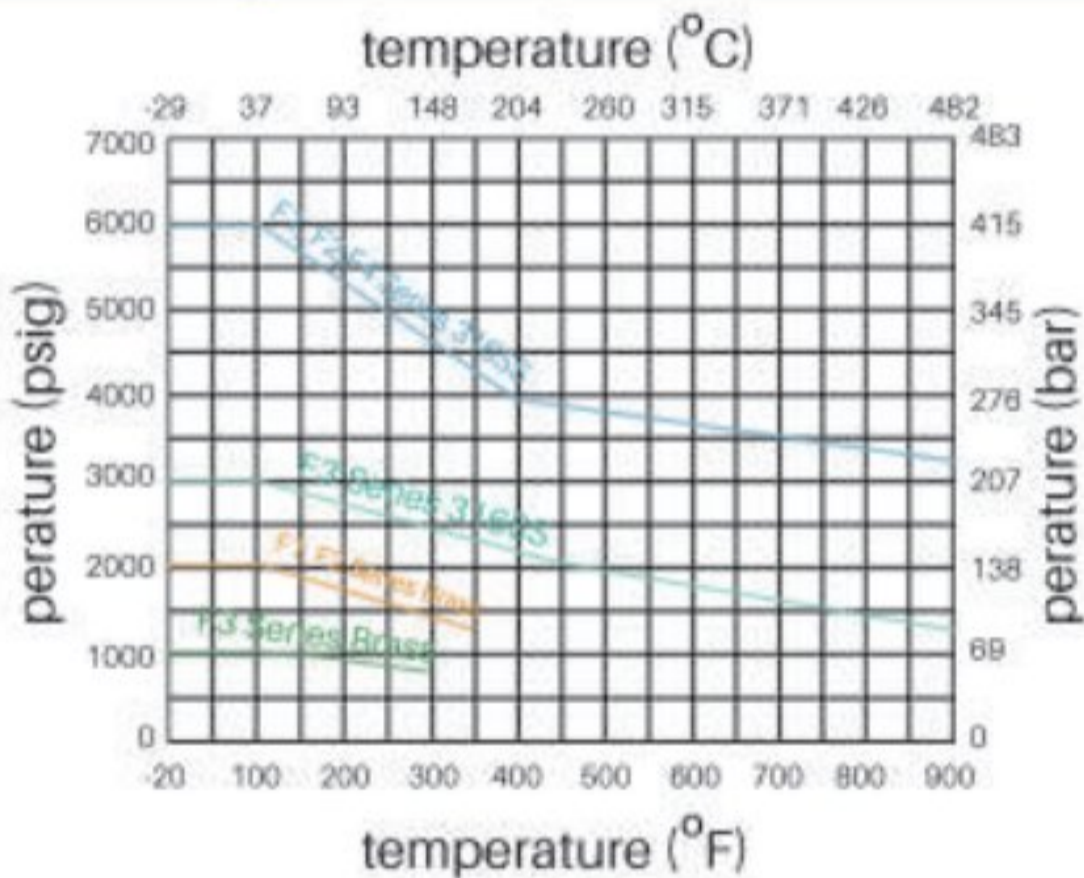

Contact the authorized representative or C-LOK for curve graph of other materials

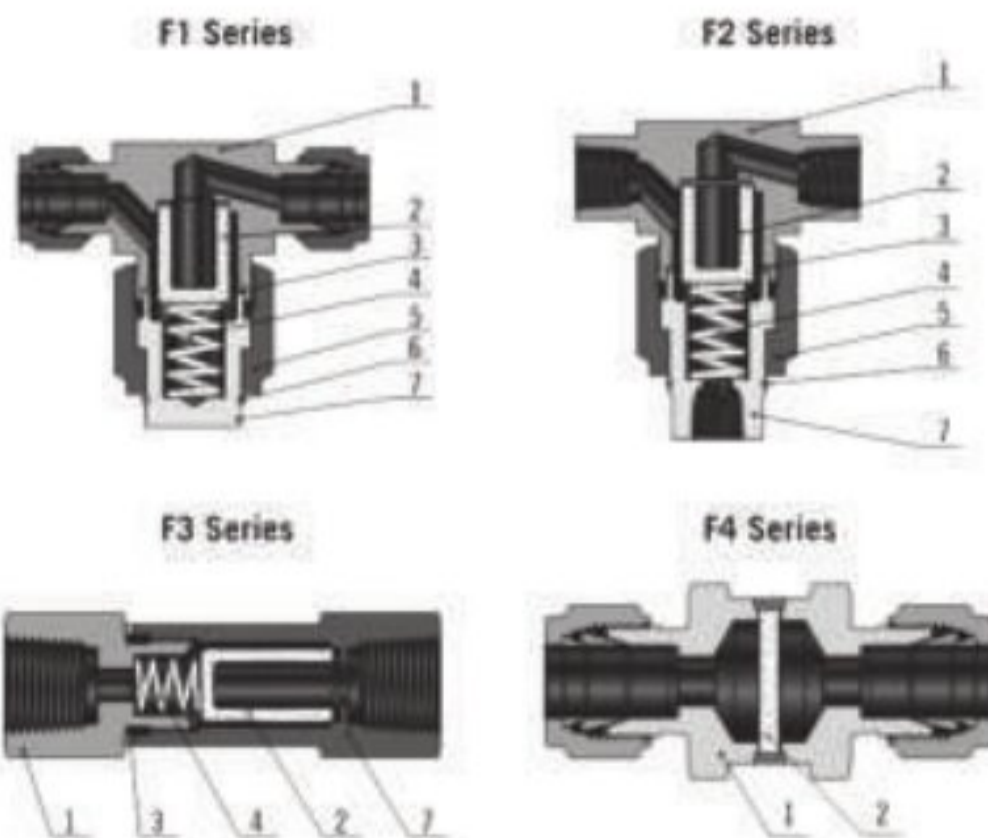

C-LOK

Instrument Valve Co., Ltd.

C-LOK the high quality instrumentation valves & fittings specialized production manufacture

Filters

F1, F2, F3 and F4 Series

Standard Material of Construction

Component		Material Grade/ASTM Specification	
		316SS	Brass
1	Body	316SS/A479	Brass/B16
2	Element	Sintered 316SS or strainer 316SS	Sintered 316SS or strainer 316SS
3	Gasket	PTFE/D1710 or silver-plated 316SS/A240	PTFE/D1710 or aluminum/B209
4	Spring	302SS/A313	302SS/A313
5	Bonnet Nut	316SS/A479	Brass/B16
6	Backup Ring	316SS/A276	
7	Bonnet	316SS/A479	Brass/B16

1. F4 Series filters not available in brass
2. Lubricants: molybdenum disulfide-based and silicone-based

Maximum Differential Pressure Clean Filter at 70°F (20°C)

Series	Maximum Differential Pressure psig (bar)										
	0.5 Micron	2 Micron	7 Micron	15 Micron	40 Micron	60 Micron	80 Micron	100 Micron	150 Micron	250 Micron	450 Micron
F1, F2, F3	2250 (155.2)	2250 (155.2)	1950 (134.2)	1750 (120.3)	1150 (79.3)	1150 (79.3)	1000 (68.9)	1000 (68.9)	1000 (68.9)	1000 (68.9)	1000 (68.9)
F4	600 (41.4)	100 (6.9)	100 (6.9)	100 (6.9)	—	—	—	—	—	—	—

Elements

Nominal Pore Sizes um	Pore Sizes Range um	Elements Type
0.5	0.5 to 2	Sintered
2	1 to 4	
7	5 to 10	
15	11 to 25	
40	35 to 53	
60	50 to 75	
80	70 to 95	
100	—	Strainer
150	—	
250	—	
450	—	



C-LOK

Instrument Valve Co., Ltd.

“ Tube Series

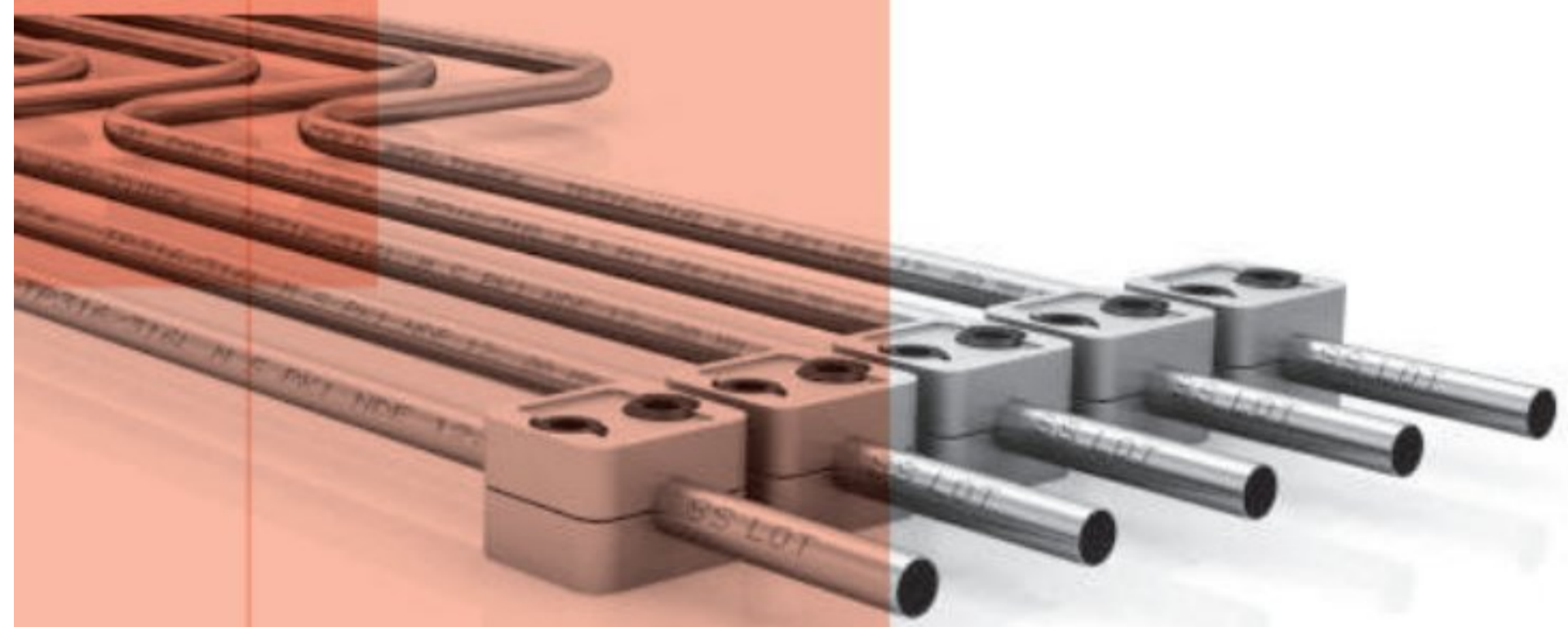

C-LOK the high quality instrumentation valves & fittings specialized production manufacture

Tubing Data

Suggested Allowable Working Pressure for Stainless Steel Tubing

Fractional Stainless Steel Seamless Tubing

Tube OD in.	Tube Wall Thickness, in.																
	0.010	0.012	0.014	0.016	0.020	0.028	0.035	0.049	0.065	0.083	0.095	0.109	0.120	0.134	0.156	0.188	
1/16	5600	6800	8100	9400	12 000												
1/8						8500	10 900										
3/16						5400	7 000	10 200									
1/4						4000	5 100	7 500	10 200 ^①								
5/16							4 000	5 800	8 000								
3/8							3 300	4 800	6 500	7500 ^{①②}							
1/2							2 600	3 700	5 100	6 700							
5/8								2 900	4 000	5 200	6 000						
3/4								2 400	3 300	4 200	4 900	5 800					
7/8								2 000	2 800	3 600	4 200	4 800					
1									2 400	3 100	3 600	4 200	4 700				
1 1/4										2 400	2 800	3 300	3 600	4 100	4 900		
1 1/2											2 300	2 700	3 000	3 400	4 000	4 900	
2												2 000	2 200	2 500	2 900	3 600	

- High-quality, fully annealed
- Type 304, 304/304L, 316, 316/316L, 317, 317/317L, 321, 347
- ASTM A269 and A213, or equivalent. Hardness not to exceed 90 HRB or 200 HV



Tubing Data

Suggested Allowable Working Pressure for Stainless Steel Tubing

Metric Stainless Steel Seamless Tubing

Tube OD mm	Tube Wall Thickness, mm														
	0.8	1.0	1.2	1.5	1.8	2.0	2.2	2.5	2.8	3.0	3.5	4.0	4.5	5.0	
3	670														
6	310	420	540	710											
8		310	390	520											
10		240	300	400	510	580									
12		200	250	330	410	470									
14		160	200	270	340	380	430								
15		150	190	250	310	360	400								
16			170	230	290	330	370	400 ^①							
18			150	200	260	290	320	370							
20			140	180	230	260	290	330	380						
22			140	160	200	230	260	300	340						
25					180	200	230	260	290	320					
28						180	200	230	260	280	330				
30						170	180	210	240	260	310				
32						160	170	200	220	240	290	330			
38							140	160	190	200	240	270	310		
50								160	190	200	240	270	310	270	

- High-quality, fully annealed
- Type 304, 304/304L, 316, 316/316L, 317, 317/317L, 321, 347
- ASTM A269 and A213, or equivalent. Hardness not to exceed 90 HRB or 200 HV



15 Series Tube Fittings and Tubes

15,000 psi (1034 bar)



C-LOK the high quality
instrumentation valves
& fittings specialized
production manufacture

“ 20 Series Tube Fittings

20,000 psi (1379 bar)



C-LOK the high quality instrumentation valves & fittings specialized production manufacture

60 Series Tube Fittings

60,000 psi (4137 bar)



C-LOK the high quality
instrumentation valves
& fittings specialized
production manufacture

“ Bellows Valves S1 S2-9.16



C-LOK the high quality
instrumentation valves
& fittings specialized
production manufacture

Block and Bleed Valves



C-LOK the high quality instrumentation valves & fittings specialized production manufacture



Flared Tube Fittings



C-LOK the high quality instrumentation valves & fittings specialized production manufacture

High Pressure Ball Valves



C-LOK the high quality instrumentation valves & fittings specialized production manufacture



High Pressure Needle Valve



C-LOK the high quality instrumentation valves & fittings specialized production manufacture

“
**Metal
Gasket
Face
Seal
Fittings**



C-LOK the high quality
instrumentation valves
& fittings specialized
production manufacture



Plug Valves



C-LOK the high quality instrumentation valves & fittings specialized production manufacture



Sample Cylinder



C-LOK the high quality instrumentation valves & fittings specialized production manufacture



Syphons



C-LOK the high quality instrumentation valves & fittings specialized production manufacture

VL
Vacuum
Fittings



C-LOK the high quality
instrumentation valves
& fittings specialized
production manufacture



Tools and Accessories



C-LOK the high quality instrumentation valves & fittings specialized production manufacture



Weld Fittings



C-LOK the high quality instrumentation valves & fittings specialized production manufacture