

















Double Block and Bleed Manifolds and Flanged Products

*Catalog 4190-FP
October 2003*



Flanged Products

Contents

Page 3	Introduction.	
Page 4/5	Application illustrations.	
Page 6	Ball valve specification.	
Page 7	Outside screw and yoke (O.S.&Y.) valve specification.	
Page 8	Globe style needle valve specification.	
Page 9	Bolted bonnet.	
Page 10/13	Monoflange (MF) manifolds.	
Page 14/17	Pro-Bloc® (PB) manifolds.	
Page 18	Pro-Bloc® (SPB) for sampling applications.	
Page 19	Pro-Bloc® (JPB) for injection applications.	
Page 20	Lapped joint tube adaptors (LJF).	
Page 21	Kidney flange to compression connectors (KF).	
Page 22	Flange to compression connectors (FC).	
Page 23	Swivel gauge adaptors (SG).	

Introduction

Parker Hannifin's response to the demand for reduction in leakage paths has been the combination of primary and secondary valves into one compact unit. The combining of piping and instrument valves into a single unit has benefitted various markets.

Benefits

- More compact design
- Reduced leakage paths
- Reduced vibration and pipework stresses
- Weight saving
- Reduced installation cost
- Choice of designs

Markets

- Offshore oil and gas platforms
- Onshore terminals
- Chemical, petro-chemical, refining
- Control panel manufacturers
- Process power industry
- LNG carriers

Parker Hannifin can offer the unique combination of double block and bleed valve systems together with integral fittings, both being designed and produced by one company.

Selection of this combination results in the elimination of taper thread connections and the need for thread sealant.

For more information on leak path reductions and how to combine connections and valves into one unit, please contact us on manifolds@parker.com

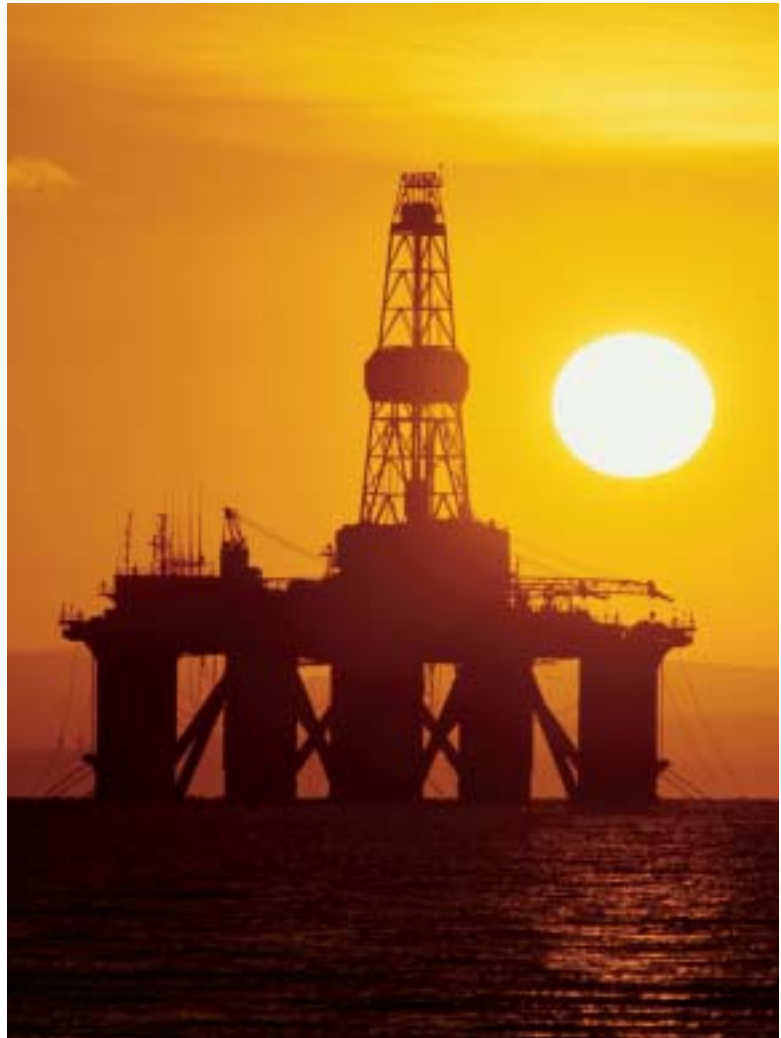

WARNING

FAILURE, IMPROPER SELECTION OR IMPROPER USE OF THE PRODUCTS AND/OR SYSTEMS DESCRIBED HEREIN OR RELATED ITEMS CAN CAUSE DEATH, PERSONAL INJURY AND PROPERTY DAMAGE.

This document and other information from Parker Hannifin Corporation, its subsidiaries and authorized distributors provide product and/or system options for further investigation by users having technical expertise. It is important that you analyze all aspects of your application and review the information concerning the product or system in the current product catalog. Due to the variety of operating conditions and applications for these products or systems, the user, through its own analysis and testing, is solely responsible for making the final selection of the products and systems and assuring that all performance, safety and warning requirements of the application are met.

The products described herein, including without limitation, product features, specifications, designs, availability and pricing, are subject to change by Parker Hannifin Corporation and its subsidiaries at any time without notice.

Offer of Sale

The items described in this document are hereby offered for sale by Parker Hannifin Corporation, its subsidiaries or its authorized distributors. This offer and its acceptance are governed by the provisions stated in the "Offer of Sale" located in Catalog 4110-U Needle Valves (U Series).

Flanged Products

Primary, secondary and vent valve applications and installations

Conventional installation

Typically this will feature a branch-welded flange, connected to a Primary ANSI class isolating valve of Ball, Gate, Globe or O.S.&Y. design. The outlet of the primary valve will be converted to instrument standards and will include a secondary instrument needle valve together with a bleed valve. A pressure gauge or transmitter will then be installed downstream of the instrument valves.

Parker Pro-Bloc®

Incorporates a body extending from a standard flange in a one-piece integral forged unit. Along the length of the extension it is possible to install and consolidate primary, secondary and bleed valves. At the end of the body extension a connection can be provided to suit any instrument, this connection could be a Parker A-LOK®, CPI™, pipe threaded NPT, BSPT, BSPP or pipe flange outlet. With Parker's Pro-Bloc® a choice of four valve designs are offered, Ball, O.S.&Y and Needle as a mixture or all of the same type. The Pro-Bloc® offers considerable space, weight and installation savings and improves safety factors through the reduction in connections. See page 14/17 for details.

Typical heights

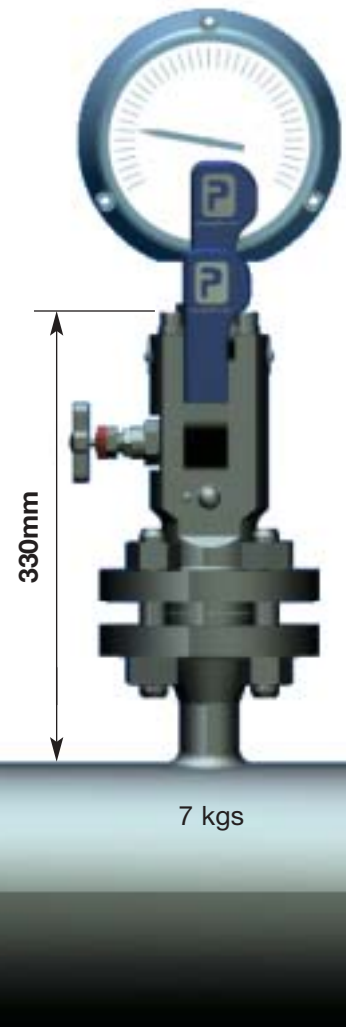
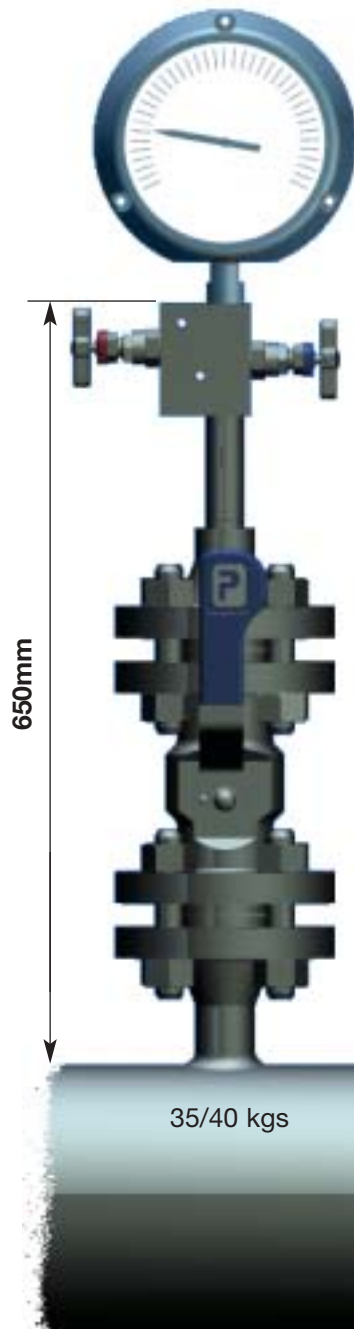

Typical

Solutions

Parker Hannifin offers the unique solution by incorporating primary and secondary valve systems into one complete block. In addition traditional instrument taper thread connections can be totally eliminated resulting in systems being free of thread sealant debris.

Design codes

All Parker Hannifin Double block and bleed designs comply with the following codes.

ANSI/ASME B16.34 (Design/material)

ANSI/ASME B1.20.1 (Threads)

ANSI/ASME B16.5 (Dimensions)

API 607/BS6755 part 2 (Fire safety – subject to specification)

Parker Monoflange

This design is more compact than Pro-Bloc® adding to further space and weight saving possibilities, primary, secondary and bleed valves are assembled on the periphery of the flange. The manifold body can incorporate both O.S.&Y. and instrument needle valves as a mixture or all of the same type. Monoflanges are available from forged or bar stock material. See page 10/13 for details.

Parker Hi-Pro Manifolds

This product range has been designed to enable the user to continue to use traditional NPT threaded connections and at the same time utilise the double block and bleed principals developed for the flanged style of products. More compact and lightweight the manifold can be supplied with a combination of ball and needle valves. Full details can be found in CAT 4190 HBM.

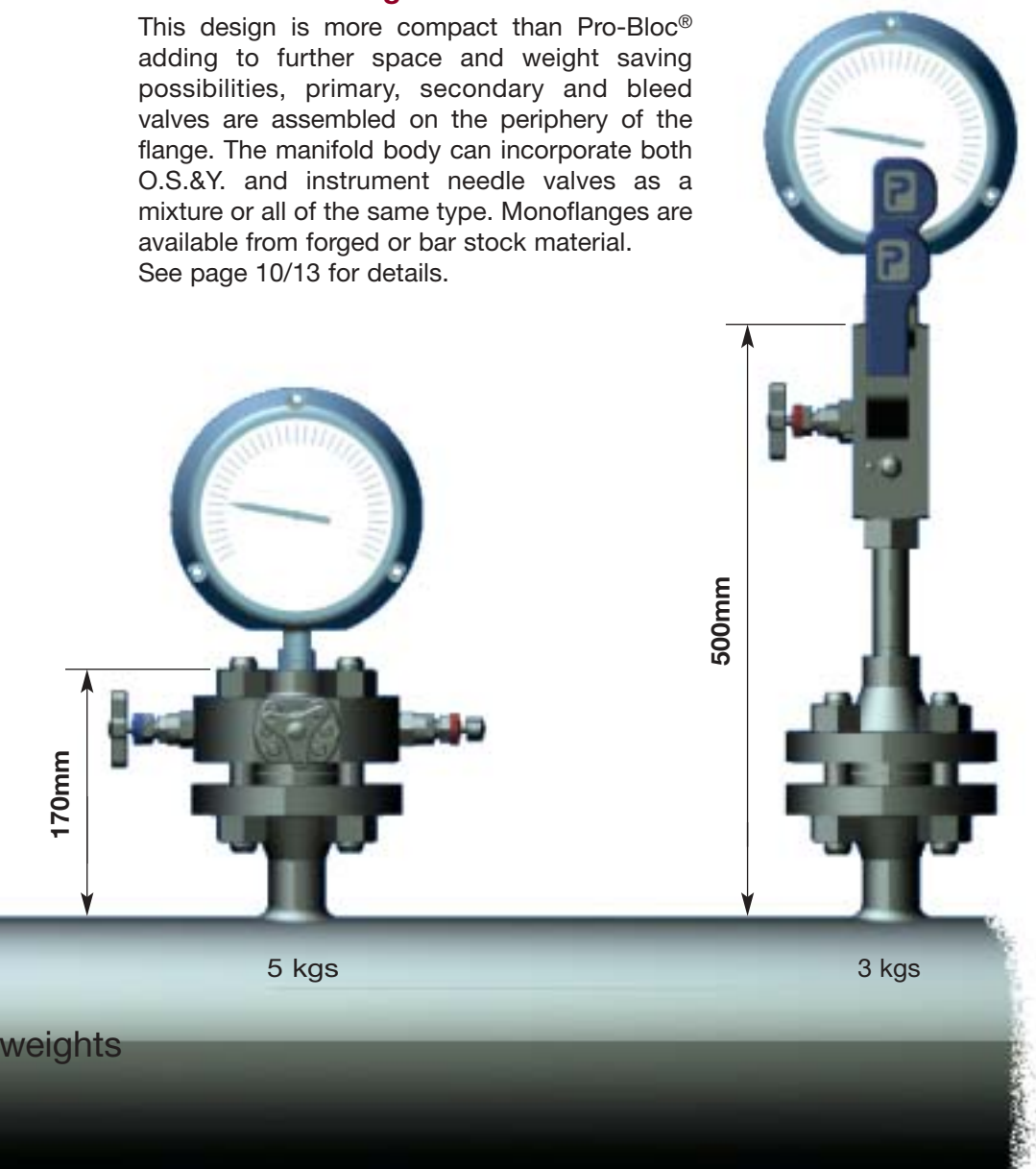

Flanged Products

Ball valve specification

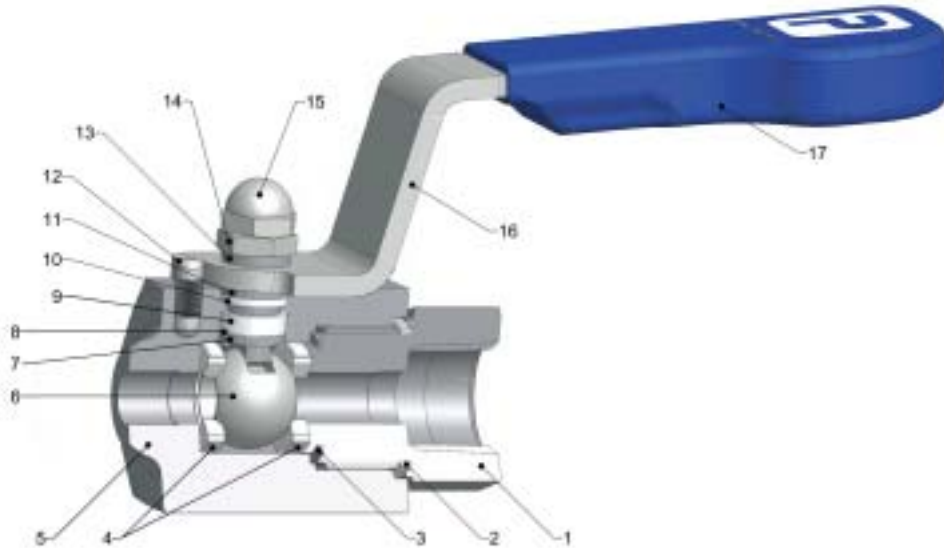

Handle locking

Specifications

- 316 Stainless steel construction.
 - Maximum cold working pressure rating 6,000 psig (414 barg) with P.T.F.E. seats.*
 - Temperature rating PTFE seats -54°C to +204°C (-65°F to +400°F).*
 - Maximum cold working pressure rating 10,000 psig (689 barg) with PEEK seats.*
 - Temperature rating PEEK seats -54°C to +232°C (-65°F to +450°F).*
- *always refer to P/T graph

Features

- Two piece body design - minimal leakage paths.
- 4:1 Pressure boundary designed safety factor.
- Designed to comply with requirements of ANSI/ASME B16.34 where applicable.
- Bi-directional.
- PEEK and P.T.F.E. standard ball seat materials.
- P.T.F.E. and Graphoil gland packings.
- Bubble tight shutoff.
- Floating ball principal with dynamic response seats featuring inherent self relief.
- Anti blowout stem.
- Integral compression ends available eliminating taper threads and thread sealants.
- Low torque operation.
- Quarter turn positive stop handle with ergonomically designed protective sleeve.
- Full hydrostatic and low pressure air tested.
- Connector thread environmentally sealed.
- Anti static.
- Firesafe designed to meet API 607, BS6755 Pt2 (optional).

Part description

Item	Description
1	End Connector
2	E-seal™
3	Sealing washer
4	Seats
5	Body
6	Ball
7	Anti blowout stem
8	Thrust Seal
9	Gland packing
10	Upper gland packing
11	Thrust bush
12	Stop pin
13	Thrust bush
14	Lock nut
15	Locking dome nut
16	Handle
17	Handle grip



Optional bolted end connector



Spanner actuation

Performance Data Pressure vs temperature

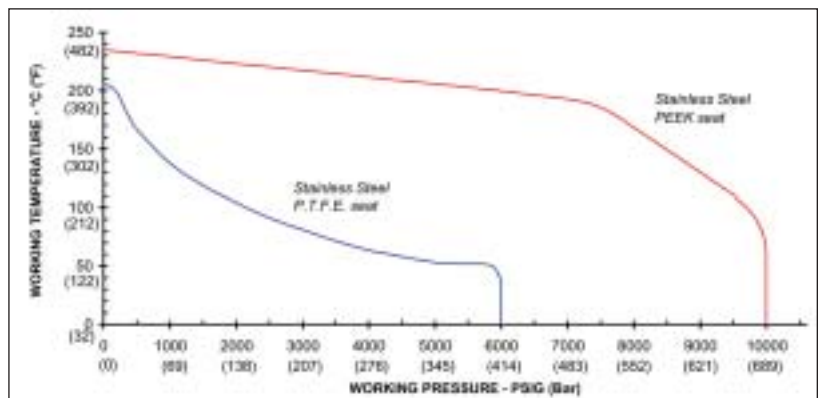

Outside screw and yoke (O.S.&Y.) needle valve

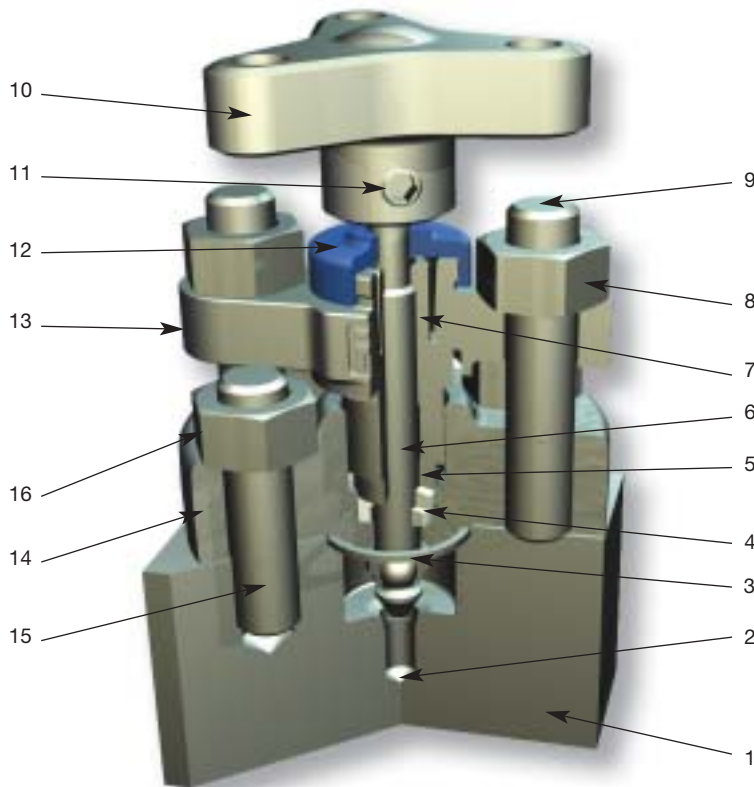

Features

- Externally adjustable gland.
- P.T.F.E. or Graphite packing for bubble tight sealing.
- Self centering crimped needle tip for bubble tight shut off and repeatability.
- Available in 316, Monel, Duplex, Super Duplex, Hasteloy, Inconel, Incoloy, 6Mo, Carbon Steel, other materials on application.
- Stainless steel as standard.
- Optional wetted parts in a variety of exotic materials.
- Firesafe certified to API 607 BS 6755 Pt 2.
- Pressure rating up to 10,000psi (690 bar).
- Temperature -54°C to 538°C (-65°F to 1000°F).
- Body to bonnet flange gasket for 100% atmospheric seal.
- Back stopped spindle for blow out prevention, and minimum atmospheric leakage.
- Rolled spindle operating threads.
- Independent spindle thread bush with maximum female thread interface.
- Colour coded close contact dust cap and function label for easy identification.
- Optional: NACE compliance, heat code trace certification, oxygen clean.

Pressure vs temperature

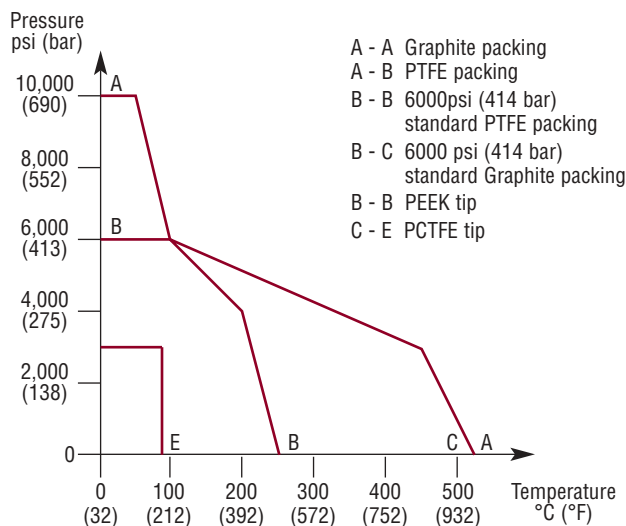

Part description

Item	Description
1	Body
2	Tip
3	Joint seal
4	Packing
5	Thrust bush
6	Stem
7	Gland adjuster
8	Bridge nuts
9	Bonnet-bridge studding
10	Handle
11	Grub screw
12	Dust cap
13	Bridge
14	Bonnet
15	Body-bonnet studding
16	Stud nuts

Flanged Products

“H” Series globe style needle valve

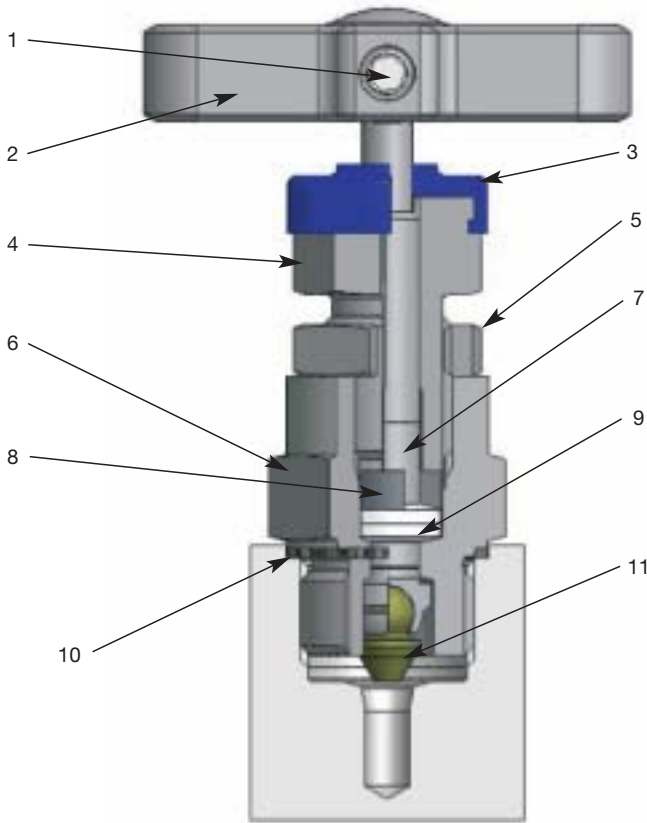

For safe reliable and repeatable performance

Part description

Item	Description
1	Positive handle retention
2	“T” bar
3	Dust Cap
4	Gland packing adjuster
5	Gland adjuster lock nut
6	Valve Bonnet
7	Anti blowout spindle
8	Thrust Bush
9	Gland packing (adjustable)
10	Bonnet/body washer
11	Spindle tip

Features

- Rolled spindle operating threads for low torque operation.
- Gland packing in PTFE or Graphite for bubble tight sealing.
- Colour coded close contact dust cap and function label for easy identification.
- Available in 316L, Monel, Duplex, Super Duplex, Hasteloy, Inconel, Incoloy, 6Mo, Titanium, other materials on application.
- T-bar operating handle for low torque function.
- Self centering crimped needle tip for bubble tight seat sealing.
- Close contact dust cap for operating thread protection.
- Back seated spindle for blow out prevention and minimum atmospheric leakage.
- Adjustable gland with easy access.
- Gland lock nut for vibration protection.
- Pressure rating up to 10,000 psi (690 bar).
- Temperature rating -54°C to -538°C (-65°F to 1000°F)
- Optional bolted bonnet design available, firesafe certified.
- Optional: NACE compliance, heat code trace certification, oxygen clean.

Pressure vs temperature

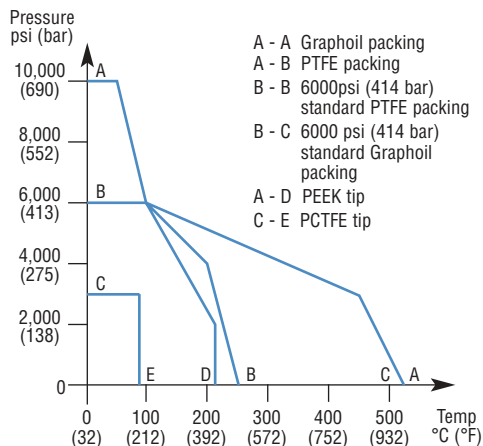

Anti tamper spindle



For key only - part no. **ATHKEY/1**

Retro-fit kit part number
KITAT without key
KITATK with key

T bar handle locking



Retro-fit kit part number **KITTHL**

Bolted bonnet

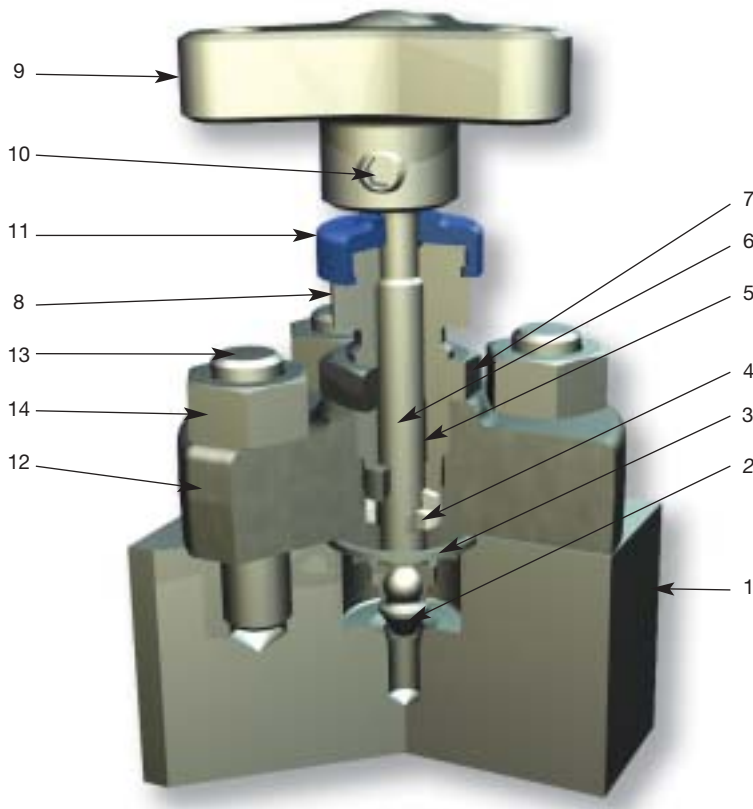

Part description

Item	Description
1	Body
2	Tip
3	Joint seal
4	Packing
5	Thrust bush
6	Stem
7	Nut
8	Gland adjuster
9	Handle
10	Grub screw
11	Dust cap
12	Bonnet
13	Body-bonnet studding
14	Stud nuts

Flanged Products

Monoflange (MF) manifolds

Purpose

This manifold range is designed to replace conventional multiple-valve installations currently in use for interface with pressure measuring systems. By combining customer specified valves into a single manifold, the number of leak paths is considerably reduced and the mass of the system is lowered reducing the stresses from loading and vibration. The result of which substantially improves installation and operational safety factors. Reduction in leakage path connections together with a one-piece solution also provides positive installation cost savings.



Key advantages of Parker Monoflanges

- Strong construction produced from one piece grain flow controlled forged body.
- Various flow and valve configurations available allowing true flexibility to meet all customer requirements.
- Variety of flange sizes and outlet connections.
- Standard materials of Carbon steel A105, Low Temperature Carbon steel A350 LF2, Stainless Steel A182-F316 and Duplex stainless steel A182-F51.
- Optional materials include Super Duplex, Monel, Hastelloy, 6Mo, Incoloy 625.
- Incorporation of standard “H” series needle valve technology and state of the art O.S.&Y. design.
- 4mm Needle valve orifice.
- Ergonomically designed operating handles with low torque function.
- Full range of customer retro fit handle options.
- User friendly part number and specification construction system.
- Customised designs welcome.

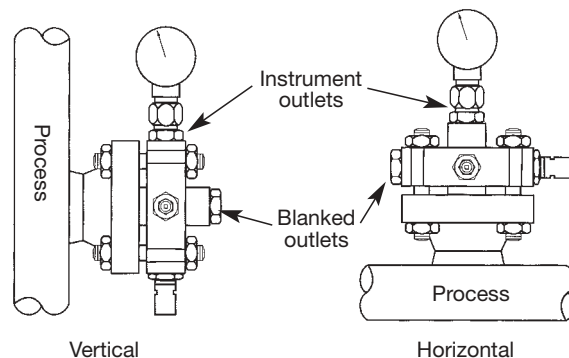

Instrument outlet connections

One of the unique features Parker can offer users which can further enhance safety factors is the incorporation of single or twin ferrule compression fittings as an integral part of the outlet connection.

Installation of the instrument which require remote positioning will be interconnected using conventional tube and fittings, whilst NPT taper threads are accepted as a standard their use involves some form of thread sealant which adds to the complication of instrument performance through contamination within the system.

Avoiding these taper thread connections wherever possible reduces this contaminant risk and Parker, being a leading manufacturer of compression type of fittings (which requires no sealant mediums), can incorporate them in the outlet connection, totally eliminating the contamination risk.

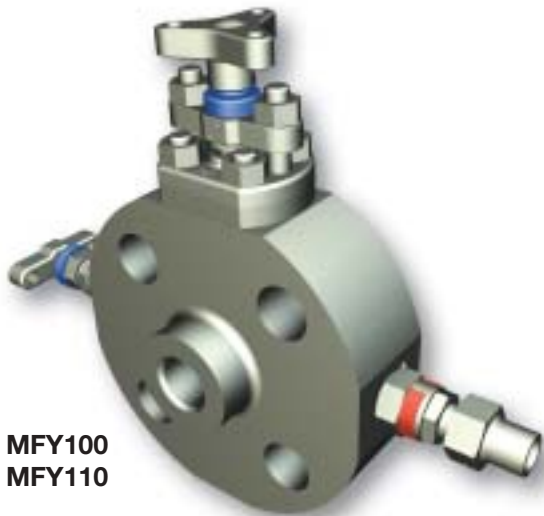

MFY100
MFY110



MFY140



MFH100
MFH110

Monoflange features

- 1/2" to 2" N.B. Flanges (15 to 50 DN).
- ANSI B16.5 150 to 2500 flange class and API 10,000.
- 1/2-14 NPT (female) standard outlet.
- 1/4-18 NPT (female) standard vent.
- Variety of optional end connection sizes and thread forms including tube connections 1/2"/12mm diameter.
- Standard materials of construction: Stainless steel ASTM A182 F316/F316L, Carbon steel ASTM A350 LF2/A105, Duplex ASTM A182 F51.
- Optional materials include Super Duplex, Monel, Hastelloy, 6Mo, Incoloy.
- Combined needle and O.S.&Y. valves available.
- Instrument connections A-LOK® inverted available.
- Raised face and ring type joint flange face styles.
- One-piece forged construction flange as standard.
- H needle design with retro fit handle options.
- Optional fire safe tested and certified to API 607, BS 6755 Pt. 2.
- Designed to meet ASME VII Div. 1.
- 4:1 Factor of Safety.
- Heat code traceable material to EN10204.3.1.B.
- Bubble tight shut off valve seats 17-4 PH tips standard.
- Optional PEEK tips available.
- Colour coded functional valves.
- Optional locking and anti tamper devices for all valve types available.
- NACE compliance available on request.
- Permanent marked body with full order and specification details.

Standard specification:











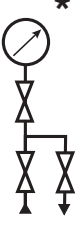

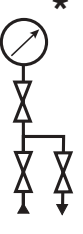

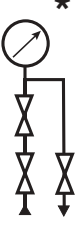

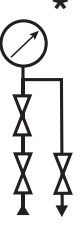





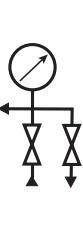

Outlet - 1/2" FNPT
Vent - plugged 1/4" FNPT
Seat - metal/metal St. St.
Packing - PTFE

Flanged Products

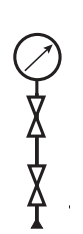
Monoflange (MF) manifold selection and part number construction - made easy

Select the style of Monoflange from the choice of arrangements below noting the complete **MF reference**.

If the style or arrangement is not shown below please provide full description and specification.

		<p>Block bleed block 1st Isolate: Needle 2nd Isolate: Needle Vent: Needle</p> <p>MFH100</p>			<p>Block bleed block 1st Isolate: O.S.&Y. 2nd Isolate: Needle Vent: Needle</p> <p>MFY100</p>
		<p>Block block bleed 1st Isolate: Needle 2nd Isolate: Needle Vent: Needle</p> <p>MFH110</p>			<p>Block block bleed 1st Isolate: O.S.&Y. 2nd Isolate: Needle Vent: Needle</p> <p>MFY110</p>
		<p>Block & bleed 1st Isolate: Needle Vent: Needle</p> <p>MFH120</p>			<p>Block & bleed 1st Isolate: O.S.&Y. Vent: O.S.&Y.</p> <p>MFY120</p>
		<p>Block & bleed 1st Isolate: Needle Vent: Needle</p> <p>MFH130</p>			<p>Block & bleed 1st Isolate: O.S.&Y. Vent: Needle</p> <p>MFY130</p>
		<p>Double block 1st Isolate: Needle 2nd Isolate: Needle</p> <p>MFH140</p>			<p>Double block 1st Isolate: O.S.&Y. 2nd Isolate: Needle.</p> <p>MFY140</p>
		<p>Single block 1st Isolate: Needle</p> <p>MFH150</p>			<p>Single block 1st Isolate: O.S.&Y.</p> <p>MFY150</p>

* For dual outlets specify MFH105, MFH115, MFY105, MFY115

Example MFY100 B 32T2500 A3 F

1. Monoflange part number
Insert from page 12

2. Material

- A Carbon Steel ASTM A105
- B Stainless Steel ASTM A182-F316
- D Monel M400
- E Duplex ASTM A182-F51
- F Super Duplex ASTM A182-F53
- G Hastelloy C-276
- H Low Temp. C. St. ASTM A350 LF2
- K 6Mo
- M Inconel 625

3. Flange details

Flange Size	Flange Face Style	Flange Class
8 = 1/2"	F = Raised Face Spiral	150 = 150 lb
12 = 3/4"	T = Ring Type Joint	300 = 300 lb
16 = 1"		600 = 600 lb
24 = 1 1/2"		900 = 900 lb
32 = 2"		1500 = 1500lb
API = specify separately		2500 = 2500lb
		* 136 = 150/300/600lb

*1/2" flange size only

8. Certification & condition

- F Firesafe design and certified
- H Heat code certificates to EN10204.3.1.B
- N NACE
Combine designators as required

7. Valve handle operating options

- A* Anti tamper
- L* Padlock handle locking
- * Insert valve number 1 = primary, 2 = secondary, 3 = vent, 4 = all.
Padlocks not supplied

4. Outlet style (1/2" NPTF is standard NO part designator needed)

Size	Connection Style
4 = 1/4"	F = Female NPT Thread
6 = 3/8"	M = Male NPT Thread
8 = 1/2"	A = A-LOK® (inverted only)
M6 = 6mm	G = Swivel gauge adaptor 1/2" NPTF (fitted)
M10 = 10mm	
M12 = 12mm	

5. Plugged vent (1/4" NPTF is standard NO part designator needed)

Size
V6 = 3/8" FNPT
V8 = 1/2" FNPT

6. Valve packing and seat materials

- * PTFE Packing
- * Needle tip 17-4PH St. St.
- 3 Graphoil (fitted as standard when fire safe design is specified)
- PN PEEK Needle tip all valves
- * fitted as standard no part NO designator required.

IMPORTANT NOTES

All non-wetted parts will be supplied in standard stainless steel for exotic materials. For carbon steel construction trim materials will be supplied in stainless steel.

Ring type joints (T) CANNOT be supplied for 1/2" & 3/4" class 150 flanges.

St. St. grades 302 and 304 are NOT used in the construction of any of these products.

For customer specific options not covered here engineering will allocate a part number at quotation stage.

Certification requirements and customer specifications MUST be provided at enquiry and order stage.

For API flange requirements full details must be specified separately.

Part number example MFY100B32T2500A3F Monoflange - Double Block and Bleed - Block (O.S.&Y.) Bleed (Needle) Block (Needle) (MFY100) - 316 St. St. construction (B) - 2" Pipe flange, Ring type joint, class 2500 (32T2500) - 1/2" female NPT outlet - 1/4" Female NPT vent - Anti-tamper vent (A3) - Firesafe design and certified (F), valves fitted with PTFE packing, metal seated 17-4PH st.st. tips.

Flanged Products

Pro-Bloc® (PB) Manifolds

Purpose

This manifold range is designed to replace conventional multiple-valve installations currently in use for interface with pressure measuring systems. By combining customer specified valves into a single manifold, the number of leak paths is considerably reduced and the mass of the system is lowered reducing the stresses from loading and vibration. The result of which substantially improves installation and operational safety factors. Reduction in leakage path connections together with a one-piece solution also provides positive installation cost savings.



Key advantages of Parker Pro-Bloc®

- Strong construction produced from one piece grain flow controlled forged body.
- Various flow and valve configurations available allowing true flexibility to meet all customer requirements.
- Single flange, double flange or triple flange configurations available.
- Standard materials of Carbon steel A105, Low Temperature Carbon steel A350 LF2, Stainless Steel A182-F316 and Duplex stainless steel A182-F51.
- Optional materials include Super Duplex, Monel, Hastelloy, 6Mo, Incoloy 625.
- Incorporation of standard Hi-Pro ball valve and “H” series needle valve technology.
- 10mm (3/8”) full bore valve design.
- Ergonomically designed operating handles with low torque function.
- User friendly part number and specification construction system.

Instrument outlet connections

One of the unique features Parker can offer users which can further enhance safety factors is the incorporation of single or twin ferrule compression fittings as an integral part of the outlet connection.

Installation of the instrument which require remote positioning will be interconnected using conventional tube and compression fittings, whilst NPT taper threads are accepted as a standard their use involves some form of thread sealant which adds to the complication of instrument performance through contamination within the system.

Avoiding these taper thread connections wherever possible reduces this contaminant risk and Parker, being a leading manufacturer of compression type of fittings (which requires no sealant mediums), can incorporate them in the outlet connection, totally eliminating the contamination risk.



PBY100



PBY220



PBY120

Pro-Bloc® features

- 1/2" to 2" N.B. Flanges (15 to 50 DN).
- ANSI B16.5 150 to 2500 flange class and API 10,000.
- 10mm (3/8") full bore valve design.
- 1/2"-14 NPT (female) standard outlet.
- 1/2" NPT (female) standard vent.
- Variety of optional end connection sizes and thread forms including tube connections up to 1/2"/12mm diameter.
- Standard materials of construction: Stainless steel ASTM A182 F316/F316L, Carbon steel ASTM A350 LF2/A105, Duplex ASTM A182 F51.
- Optional materials include Super Duplex, Monel, Hastelloy, 6Mo, Incoloy.
- Instrument connections A-LOK®/CPI™ available.
- Raised face and ring type joint flange face styles.
- One-piece forged construction flange as standard.
- Ball valve designed to BS 5351.
- Optional fire safe tested and certified to API 607, BS 6755 Pt. 2.
- 316 stainless steel handles and trim as standard to reduce the risk of corrosion.
- Designed to meet ASME VII Div. 1.
- 4:1 Factor of Safety.
- Heat code traceable material to EN10204.3.1.B.
- Bubble tight shut off.
- Colour coded functional valves.
- Optional locking and anti tamper devices for all valve types available.
- Positive lever stop.
- NACE compliance available on request.
- Large user friendly handles.
- Permanent affixed reference label.
- O.S.&Y. and "H" series needle valves can be combined with ball valves.

Standard specification flange x screw:
 Outlet - 1/2" FNPT. Vent - 1/2" FNPT plugged.
 Ball seats. P.T.F.E., Needle seats, metal/metal
 174 PH St. St. P.T.F.E. packing all valves.

Flanged Products

Pro-Bloc® (PB) manifold selection and part number construction - made easy

Select the style of Pro-Bloc from the choice of arrangements below noting the complete **PB reference**.

If the style or arrangement is not shown below please provide full description and specification.

	<p>Block bleed block Flange x screw 1st Isolate: Ball 2nd Isolate: Ball Vent: Needle</p>  <p>PBY100</p>		<p>Block bleed block Flange x flange 1st Isolate: Ball 2nd Isolate: Ball Vent: Needle</p>  <p>PBY200</p>
	<p>Block bleed block Flange x screw 1st Isolate: Ball 2nd Isolate: Needle Vent: Needle</p>  <p>PBY110</p>		<p>Block bleed block Flange x flange 1st Isolate: Ball 2nd Isolate: Needle Vent: Needle</p>  <p>PBY210</p>
	<p>Block bleed block Flange x screw 1st Isolate: Ball 2nd Isolate: Ball Vent: Ball</p>  <p>PBY120</p>		<p>Block bleed block Flange x flange 1st Isolate: Ball 2nd Isolate: Ball Vent: Ball</p>  <p>PBY220</p>
	<p>Block & bleed Flange x screw 1st Isolate: Ball Vent: Needle</p>  <p>PBY130</p>		<p>Block & bleed Flange x flange 1st Isolate: Ball Vent: Needle</p>  <p>PBY230</p>
	<p>Block & bleed Flange x screw 1st Isolate: Ball Vent: Ball</p>  <p>PBY140</p>		<p>Block & bleed Flange x flange 1st Isolate: Ball Vent: Ball</p>  <p>PBY240</p>
	<p>Double block Flange x screw 1st Isolate: Ball 2nd Isolate: Needle</p>  <p>PBY150</p>		<p>Double block Flange x flange 1st Isolate: Ball 2nd Isolate: Needle</p>  <p>PBY250</p>
	<p>Double block Flange x screw 1st Isolate: Ball 2nd Isolate: Ball</p>  <p>PBY160</p>		<p>Double block Flange x flange 1st Isolate: Ball 2nd Isolate: Ball</p>  <p>PBY260</p>

* For single block  specify PBY165, PBY265

Example **PBY100** **B** **32T2500** **F**

1. Pro-Bloc part number
Insert from page 16

- 2. Material**
- A Carbon Steel ASTM A105
 - B Stainless Steel ASTM A182-F316
 - D Monel M400
 - E Duplex ASTM A182-F51
 - F Super Duplex ASTM A182-F53
 - G Hastelloy C-276
 - H Low Temp. C. St. ASTM A350 LF2
 - K 6Mo
 - M Inconel 625

3. Flange details

Flange Size	Flange Face Style	Flange Class
8 = 1/2"	F = Raised Face Spiral	150 = 150 lb
12 = 3/4"	T = Ring Type Joint	300 = 300 lb
16 = 1"		600 = 600 lb
24 = 1 1/2"		900 = 900 lb
32 = 2"		1500 = 1500lb
API = specify separately		2500 = 2500lb

- 8. Certification & condition**
- F Firesafe design and certified
 - H Heat code certificates to EN10204.3.1.B
 - N NACE
- Combine designators as required

- 7. Valve handle operating options**
- A* Anti tamper (Needle Valve only)
 - L* Padlock handle locking
 - S* Spanner actuated (Ball Valve only)
- * Insert valve number 1 = primary, 2 = secondary, 3 = vent, 4 = all. Padlocks not supplied

4. Outlet style (1/2" NPTF is standard NO part designator needed)

Size	Connection Style
4 = 1/4"	F = Female NPT Thread
6 = 3/8"	M = Male NPT Thread
8 = 1/2"	A = A-LOK
M6 = 6mm	Z = CPI
M10 = 10mm	G = Swivel gauge adaptor 1/2" NPTF (fitted)
M12 = 12mm	

- 5. Plugged vent (1/2" NPTF is standard NO part designator needed)**
- | Size |
|----------------|
| V4 = 1/4" FNPT |
| V6 = 3/8" FNPT |

- 6. Packing, seat and construction options**
- * PTFE Packing
 - * PTFE Ball seats
 - * Needle tip 17-4PH St. St.
 - 3 Graphoil (fitted as standard when fire safe design is specified)
 - PK PEEK Ball and needle seating
 - PB PEEK Ball seats
 - PN PEEK Needle tip
 - BC Bolted construction connection
- * fitted as standard no part NO designator required.

IMPORTANT NOTES

All none wetted parts will be supplied in standard stainless steel for exotic materials. For carbon steel construction trim materials will be supplied in stainless steel.

For flange to flange construction when the required flanges are different sizes then specify both sizes in section 3 example: 1st flange 1" pipe (16), raised face (F), class 900 (900), 2nd flange 1/2" (8), raised face (F), class 900 (900) insert: 16F9008F900.

Ring type joints (T) CANNOT be supplied for 1/2" & 3/4" class 150 flanges.

St. St. grades 302 and 304 are NOT used in the construction of any of these products.

For customer specific options not covered here engineering will allocate a part number at quotation stage.

Certification requirements and customer specifications MUST be provided at enquiry and order stage.

For API flange requirements full details must be specified separately.

Part number example PBY100B32T2500F Pro-Bloc - Flange by screw - Double Block and Bleed - Block (Ball) Bleed (Needle) Block (Ball) (PBY100) - 316 St. St. construction (B) - 2" Pipe flange, Ring type joint, class 2500 (32T2500) - 1/2" female NPT outlet - 1/2" Female NPT vent - Firesafe design and certified (F), all valves PTFE packed, ball seats PTFE, needle valve metal seated 17-4PH st.st. tips.

Flanged Products

Pro-Bloc® (PB) Manifolds

Pro-Bloc® for sampling applications

This manifold range is designed to replace conventional multiple-valve installations where sampling of the process stream is required. This design has been developed to remove a sample directly from the process stream at full system pressure. All of the options and configurations shown within the standard Pro-Bloc range can be offered for sampling service by the addition of a customised sampling probe which extends from the pipe flange into the process stream.

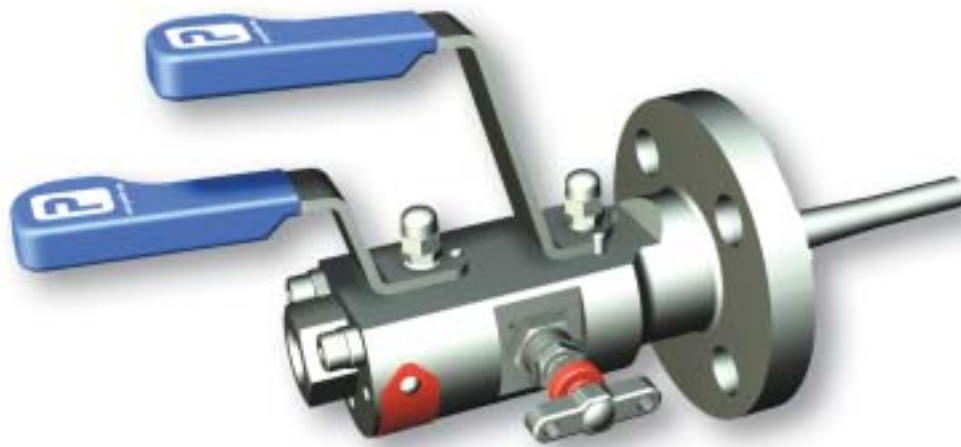

Pro-Bloc® for sampling applications - part numbering

In order to specify the addition of a sampling probe to your Pro-Bloc simply add an “S” to the beginning of the part number i.e. SPB... The probe length in “mm” must be added to the end of the part number, see below. Due to the internal bore size of standard ASME flanges probes can only be installed on a range of flanges - please see the attached table.



Size	Class
3/4"	150lb
1"	
1 1/2"	
2"	
3/4"	300lb
1"	
1 1/2"	
2"	
3/4"	600lb
1"	
1 1/2"	
2"	
3/4"	900/1500lb
1"	
1 1/2"	
2"	
3/4"	2500lb
1"	
1 1/2"	
2"	

The probe length must be specified from the raised face to the end of the probe in mm, to the nearest mm. Probes are supplied to suit the insertion length required by the pipeline and thus must be specified by the customer.

A wide variety of end preparations and support collars are available on request.

Probe strength wake frequency calculations can be carried out against pipeline flow rates on request.

In the event of the required valve configuration not be shown please do not hesitate to contact the factory as Parker Hannifin IPD offer bespoke customer solutions.

Pro-Bloc® (PB) Manifolds

Pro-Bloc® for injection applications

This manifold range is designed to replace conventional multiple-valve installations where injection into the process stream is required. This design has been developed to inject directly into the process stream at full system pressure. All of the options and configurations shown within the standard Pro-Bloc range can be offered for injection service by the addition of a customised injection probe which extends from the pipe flange into the process stream. Pro-Bloc's for injection applications include an injection probe which enables the fluid to be injected directly into the process stream and a high integrity full bore non-return valve to eliminate the risk of back flow out of the process stream.



Pro-Bloc® for injection applications - part numbering

In order to specify the addition of an injection probe and non-return valve to your Pro-Bloc simply add an "J" to the beginning of the part number i.e. JPB... The probe length in "mm" must be added to the end of the part number, see below. Due to the internal bore size of standard ASME flanges probes can only be installed on a range of flanges - please see the table in the sampling Pro-Bloc section (page 19).

The probe length must be specified from the raised face to the end of the probe in mm, to the nearest mm. Probes are supplied to suit the insertion length required by the pipeline and thus must be specified by the customer.

A wide variety of end preparations and support collars are available on request.

Probe strength wake frequency calculations can be carried out against pipeline flow rates on request.



Hi-Check non-return valve

This high integrity full bore non-return valve eliminates the risk of back flow out of the process stream. The design utilises a spring loaded poppet to ensure leak proof performance. The Hi-Check Non Return Valve is designed for higher flow and low pressure drop across the valve - having a larger through bore than most other manufacturers equivalent product.

As standard a viton seal will be supplied with a "crack" pressure of 25psi. A wide variety of seat materials and crack pressures are available on request.

In the event of the required valve configuration not being shown please do not hesitate to contact the factory as Parker Hannifin IPD offer bespoke customer solutions.



Flanged Products

Lapped joint tube adaptors (LJF)

Purpose

For applications involving small flanged process valves with simple conversion to instrument lines, slipover flanges are available.



Specification

- 1/2" to 2" N.B. flanges (15 to 50DN).
- 150 to 2500lb flange class.
- Flange sealing:-
 - Raised face rough spiral finish.
 - Raised face smooth spiral finish.
- Standard or inverted A-LOK® arrangement 1/4" to 1" O.D. (3mm to 25mm O.D.).
- Standard or inverted CPI™ compression fitting 1/4" to 1" O.D. (3mm to 25mm O.D.).
- Standard stainless steel body (316).
- Other materials on application.

Features

- Full heat code traceability to DIN 50049.3.1.B.
- Integrally machined body, no welding.
- Eliminates additional connections.
- P.T.F.E. tape or liquid thread sealants not required.
- Optional slipover flanges available.
- Pressure ratings compliant with ANSI up to class 2500.

Part number construction

	Product code	Material (use table 2 page 13)	Connection A-LOK maximum size 1" / 25mm	Flange size details from table 3 page 13		
				Flange size	Class (to be specified when slipovers required)	Optional slipover flanges (SF)
Example 1	LJF	B	8A	8	600	SF
Example 2	LJF	D	M6A	12		

For CPI™ change A to Z.

For A-LOK® size codes use the A-LOK® catalogue.

Example 1: LJFB8A8600SF - Stainless steel, 1/2" o.d. A-LOK® tube connection to 1/2" (DN15) pipe flange, supplied with Class 600 slipover flange.

Example 2: LJFDM6A12 - Monel 400, 6mm o.d. A-LOK® tube connection to 3/4" (DN20) pipe flange.

Flange class must be specified when ordering slipover flange options.

Kidney flanges to compression connectors (KF)

Purpose

Integral A-LOK twin ferrule connection for simple and safe connection from process measurement impulse line to instrument or manifold. Parker integral Kidney flanges (ovals), enable the user to eliminate the use of taper threads and thread sealant thereby increasing the integrity of the instrument system by avoiding the risk of sealant medium contamination.



Specification

- Rated to 6000psi.
- Standard to PTFE seal ring.
- Optional Graphite available.
- Standard stainless steel body (316L).
- Standard A-LOK® connection up to 1/2" or 12mm O.D. tube.
- Standard CPI™ connection up to 1/2" or 12mm O.D. tube.
- Other materials on application.
- High tensile carbon steel bolts supplied as standard 2 x 7/16 UNF x 1.625".

Features

- Full heat code traceability to DIN 50049.3.1.B.
- 1/2" NB Sch.40 to Sch XXS butt weld connections available on request.
- Integrally machined body, no welding.
- Eliminates additional connections.
- P.T.F.E. tape or liquid thread sealants not required.
- NACE compliance available on request.

Part number construction

	Product code	Material (use table 2 page 13)	Connection A-LOK maximum size 1/2" / 12mm	Stainless steel bolts optional (SSB)	Graphite option (3)	NACE optional (N)
Example 1	KF	B	8A	–	3	–
Example 2	KF	B	8F	SSB		N

For CPI™ change A to Z.

For A-LOK® size codes use the A-LOK® catalogue.

Example 1: KFB8A3 - Stainless steel, 1/2" o.d. A-LOK® tube connection, graphite sealing ring, 2 carbon steel bolts.

Example 2: KFB8FSSBN - Stainless steel, 1/2" Female NPT thread, P.T.F.E. sealing ring, 2 stainless steel bolts, complies to NACE.

Flanged Products

Flange to compression connectors (FC)

Purpose

One piece integral connectors allow the user to switch from piping flange standards to instrument compression with minimum cost and added safety. This system eliminates the need for additional connections.



Specification

- 1/2" to 2" N.B. flanges (15 to 50DN).
- 150 to 2500lb flange class.
- Flanges to ANSI B16.5.
- Standard or inverted A-LOK® compression fitting 1/4" to 1" O.D. (3mm to 25mm O.D.).
- Standard or inverted CPI™ compression fitting 1/4" to 1" O.D. (3mm to 25mm O.D.).
- Flange sealing:-
 - Raised face rough spiral finish.
 - Raised face smooth spiral finish.
 - Ring type joint.
- Standard stainless steel body (316L).

Features

- Full heat code traceability to DIN 50049.3.1.B.
- Integrally machined body, no welding.
- Eliminates additional connections.
- P.T.F.E. tape or liquid thread sealants not required.
- Variety of materials available.
- NACE compliance available on request.

Part number construction

Part number construction				Flange size details from table 3 page 13		
	Product code	Material (use table 2 page 13)	Connection A-LOK maximum size 1" / 25mm	Flange size	Face style	Class
Example 1	FC	B	8A	16	F	600
Example 2	FC	K	M12A	8	T	1500

For CPI™ change A to Z.

For A-LOK® size codes use the A-LOK® catalogue.

Example 1: FCB8A16F600 - Stainless steel, 1/2" o.d. A-LOK® tube connection, 1" pipe flange, raised face, class 600.

Example 2: FCKM12A8T1500 - 6Mo, 12mm o.d. A-LOK® tube connection to 1/2" pipe flange, ring type joint, class 1500.

Swivel gauge adaptors

Purpose

Parker's range of swivel gauge adaptors have been designed to provide 360° rotational movement enabling maximum positional orientation of installed gauges and measuring instruments. A fully contained sealing mechanism ensures total system integrity and offers the user up to 10,000 psig (690 barg) working pressure. Silver plated swivel nut thread and bearing area prevent thread galling of stainless steel threads and allow trouble free repeatable re-assembly.



Specification

- 316 Stainless steel standard.
- 1/2" NPT male to 1/2" NPT female standard.
- 6,000 psig (414 barg) maximum pressure rating.
- Maximum temperature rating 260°C (500°F).
- Fully heat code traceable.
- Height = 66mm (2.60").
- A/F1 = 19mm (3/4").
- A/F2 = 31.8mm (1 1/4").

Options

- Optional materials:
Monel M400, Duplex, Super Duplex, Hastelloy, 6Mo, Inconel 625.
- Optional BSPP, BSPT & Metric male/female threads, BSPP female DIN 16288 spigot seal outlet arrangement.
- Note: for washers see CAT 4233 page 72 A-LOK®.
- 10,000 psig (689 barg) optional pressure rating.
- Graphoil packing for high temperature maximum 538°C (1,000°F).
- NACE compliance.
- Heat code traceable certification.

Part number construction

	Product code	Material (use table 2 page 13)	Inlet connection NPT standard	Outlet connection NPT standard	Graphoil option (3)	High pressure option (HP)	NACE optional (N)
Example 1	SG	B	8M	8F	3	HP	-
Example 2	SG	B	6M	8F			N

For male outlet change F to M.

For BSPP suffix M and/or F with R.

For BSPT suffix M and/or F with K.

For DIN 16288 spigot seal suffix F with RDIN.

Example 1: Stainless steel 1/2" NPT male inlet, 1/2" NPT female outlet, with graphoil seal and 10,000 psi (689 bar) rating.

Example 2: Stainless steel 3/8" NPT male inlet, 1/2" NPT female outlet, with P.T.F.E. (standard) and in accordance with NACE requirements.

Features

- Silver plated swivel thread and bearing surface to prevent thread galling and maximising re-make opportunities.
- Variety of thread options.
- Compact design.
- Fully contained and retained sealing mechanism. F44.

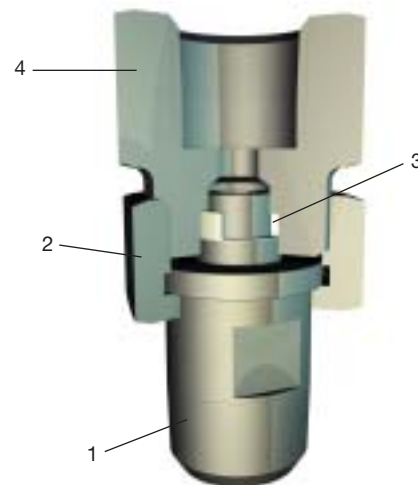

Part description

Item	Description
1	Inlet connector
2	Swivel nut
3	Seal
4	Gauge outlet connector