

Bleed / Purge Valves (BV & PG Series)

*Catalog 4133-BP
Revised, February 2002*



Bleed Valves

Introduction

Parker BV Series Bleed Valves are designed for use on products such as multi-valve manifolds or gauge/root valves. Functionally, the valve vents line pressure either to atmosphere or to containment when used with the optional barbed vent tube. Generally, bleed valves are used whenever an instrument is removed from a system or to assist in the calibration of control devices. The BV Series is also recommended for use in bleeding hydraulic systems.

Features

- Available in stainless steel, carbon steel and Alloy N24135
- Vent tube directs excess gas or liquid from system lines
- Chrome plated stem provides extended cycle life with improved sealability
- Positive stop/vent tube design prevents accidental removal of the stem
- Compact design
- Wrench actuation
- Available in a variety of end configurations including male pipe and SAE ports
- 100% factory tested
- Barbed vent tube option enables containment of vented media
- Optional T-bar handle for wrench-less actuation

Specifications

Pressure Rating:

10,000 psig (689 bar) CWP

Temperature Rating:

Stainless Steel:

-65 °F to 850 °F (-54 °C to 454 °C)

Carbon Steel:

-20 °F to 450 °F (-29 °C to 232 °C)

Alloy N24135 (400):

-65 °F to 500 °F (-54 °C to 260 °C)

Flow Data

$C_v = 0.13$; $x_T = 0.53$; Orifice = 0.125" (3.2mm).
Tested in accordance with ISA S75.02. Gas flow will be choked when $P_1 - P_2 / P_1 = x_T$

Caution

These valves do not have a stem seal. It is imperative to open the valve slowly and direct the vent tube away from persons operating or near the valve. Because of the absence of a stem seal, small amounts of media will flow through the stem thread area when the valves are opened.

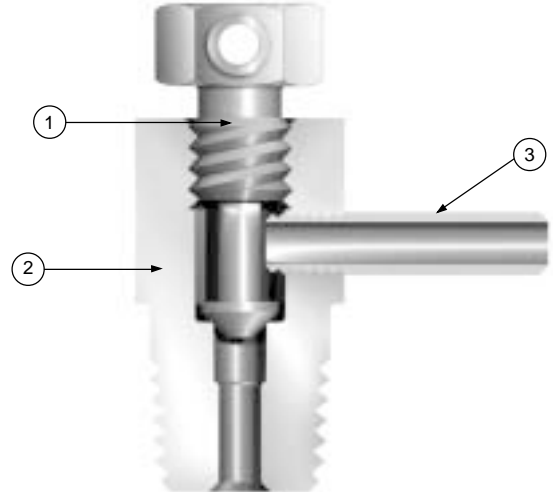

Model Shown: 4M-BV4-SS

Materials of Construction

Item #	Part	Stainless Steel	Carbon Steel	Alloy 400
1	Stem	ASTM A 479, Type 316		ASTM B 164
2	Valve Body	ASTM A 479, Type 316	ASTM A 108, Grade 12L14	ASTM B 164
3	Vent Tube	316 SS		ASTM B 164

Lubrication: Molybdenum disulfide with soft metallic fillers

Available Purge Valve End Connections

Z-Single ferrule CPI™ compression port



A-Two ferrule A-LOK® compression port



M-ANSI/ASME B1.20.1, External pipe threads



F-ANSI/ASME B1.20.1, Internal pipe threads



F5-SAE J1926/2 Part 2: Heavy-duty (S Series) stud ends



TA-Tube adapter connection



Introduction

Parker PG Series Purge Valves may be utilized as either bleed, purge, or drain valves. The compact valve requires only a quarter turn with a wrench from finger-tight to ensure a leak-tight seal on the first make-up. Additional wrenching ensures a leak-tight seal up to the rated pressure.

Features

- A 0.055 inch (1.4 mm) diameter vent hole in the cap bleeds, drains, or purges system pressure
- Hex cap permits finger-tight or wrench assisted closure
- Crimped cap resists accidental disassembly
- A variety of body styles offers system design flexibility, reduced space requirements, and helps to eliminate leak paths
- Available in a variety of end configurations including: CPI™, A-LOK®, male and female NPT, SAE, and Tube Adapter connections
- 100% factory tested
- Optional PTFE Ball requires only finger-tight torque to achieve a leak-tight seal

Specifications

Temperature Rating:

Stainless Steel:

-65 °F to 600 °F (-54 °C to 316 °C)

Brass:

-65 °F to 400 °F (-54 °C to 204 °C)

Carbon Steel:

-20 °F to 350 °F (-29 °C to 177 °C)

PTFE Ball Option:

-65 °F to 350 °F (-54 °C to 177 °C)

Pressure Rating:

Stainless Steel: 4000 psig (276 bar) CWP

Brass: 3000 psig (207 bar)

Carbon Steel: 3000 psig (207 bar)

PTFE Ball Option: 200 psig (14 bar)

Caution

These valves do not have a cap thread seal. It is imperative to open the valve slowly and direct the vent hole away from persons operating or near the valve. Because of the absence of a cap seal, small amounts of media will flow through the cap thread area when the valves are opened.

PTFE Ball Option

Purge Valves with the PTFE ball option require only finger-tight operation for leak-tight shut-off and are designed with a removable cap for ball replacement.

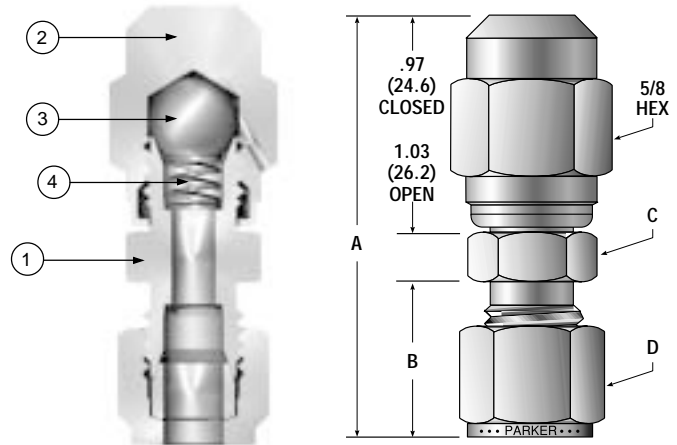

Models Shown: 4Z-PG4L-SS

() Denotes dimensions in millimeters

Materials of Construction

Item #	Part	Stainless Steel	Brass	Carbon Steel
1	Body	ASTM A 479, Type 316	ASTM B 16, Alloy C36000	ASTM A 108, Grade 12L14
2	Cap	ASTM A 479, Type 316	ASTM B 16, Alloy C36000	ASTM A 108, Grade 12L14
3	Ball	316 Stainless Steel*		
4	Spring	316 Stainless Steel		

* Optional PTFE Ball available

Lubrication: Molybdenum disulfide with soft metallic fillers

Available Purge Valve Models



Straight (L)

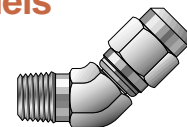

45° Elbow (E)

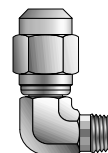

90° Elbow (A)

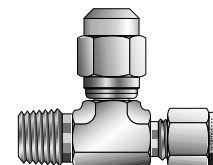

Inline Tee (TL)

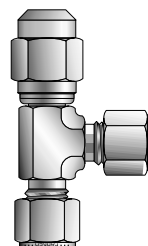

Angle Tee (TA)

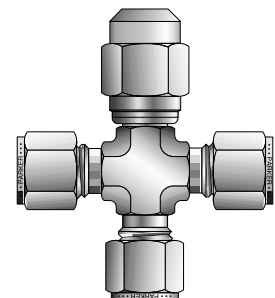

Union (U)

Dimensions

End Connections	A* (Closed)		B*		C (hex)		D (hex)	
	Inch	mm	Inch	mm	Inch	mm	Inch	mm
2A - 1/8" A-LOK® Compression	1.79	45.5	0.60	15.2	0.50	12.7	0.44	11.2
2Z - 1/8" CPI™ Compression	1.79	45.5	0.60	15.2	0.50	12.7	0.44	11.2
2M - 1/8" Male NPT	1.56	39.6	0.38	9.7	0.50	12.7	-	-
2F - 1/8" Female NPT	1.50	38.1	0.53	13.5	0.56	14.2	-	-
2TA - 1/8" Tube Adapter	1.69	42.9	0.55	14.0	0.50	12.7	-	-
4A - 1/4" A-LOK® Compression	1.88	47.8	0.70	17.8	0.50	12.7	0.56	14.2
4Z - 1/4" CPI™ Compression	1.88	47.8	0.70	17.8	0.50	12.7	0.56	14.2
4M - 1/4" Male NPT	1.76	44.7	0.56	14.2	0.56	14.2	-	-
4F - 1/4" Female NPT	1.69	42.9	0.72	18.3	0.75	19.1	-	-
4F5 - 1/4" Male SAE	1.78	45.2	0.41	10.4	0.75	19.1	-	-
4TA - 1/4" Tube Adapter	1.91	48.5	0.72	18.3	0.50	12.7	-	-
6A - 3/8" A-LOK® Compression	1.98	50.3	0.76	19.3	0.63	16.0	0.69	17.5
6Z - 3/8" CPI™ Compression	1.98	50.3	0.76	19.3	0.63	16.0	0.69	17.5
6M - 3/8" Male NPT	1.78	45.2	0.56	14.2	0.69	17.5	-	-
6F - 3/8" Female NPT	1.75	44.5	0.78	19.8	0.88	22.4	-	-
6TA - 3/8" Tube Adapter	1.97	50.0	0.78	19.8	0.50	12.7	-	-
M6A - 6mm A-LOK® Compression	1.88	47.8	0.70	17.8	0.55	14.0	0.55	14.0
M6Z - 6mm CPI™ Compression	1.88	47.8	0.70	17.8	0.55	14.0	0.55	14.0
8A - 1/2" A-LOK® Compression	2.12	53.8	0.87	22.1	0.81	20.6	0.88	22.4
8Z - 1/2" CPI™ Compression	2.12	53.8	0.87	22.1	0.81	20.6	0.88	22.4
8M - 1/2" Male NPT	2.03	51.6	0.75	19.1	0.88	22.4	-	-
8F - 1/2" Female NPT	1.94	49.3	0.97	24.6	1.06	26.9	-	-
8F5 - 1/2" Male SAE	2.08	52.8	0.47	11.9	1.13	28.7	-	-
8TA - 1/2" Tube Adapter	2.22	56.4	1.03	26.2	0.56	14.2	-	-
M8A - 8mm A-LOK® Compression	1.97	50.0	0.75	19.1	0.63	16.0	0.63	16.0
M8Z - 8mm CPI™ Compression	1.97	50.0	0.75	19.1	0.63	16.0	0.63	16.0

* For CPI™ and A-LOK®, dimensions are measured with nuts in the finger tight position.

How to Order Purge Valves

The correct part number is easily derived from the following number sequence. The seven product characteristics required are coded as shown below. Note: If the ports are the same, only specify one end connection.

Example: 2M - PG4 A - SS - T
 (1)(2)(3) (4) (5) (6) (7)

Describes a stainless steel, 90° angle body PG4 Purge Valve with a 1/8" male NPT port configuration and a PTFE Ball.

End Connection ① ② ③	Valve Series ④	Body Type ⑤	Material ⑥	Ball ⑦
2A, 2Z, 2F, 2M, 2TA	PG4	L - Straight	SS - Stainless Steel	Blank- Stainless Steel
4A, 4Z, 4F, 4F5*, 4M, 4TA		A - 90° Elbow		
6A, 6Z, 6F, 6M 6TA, M6A, M6Z		E - 45° Elbow	B - Brass	T - PTFE
8A, 8Z, 8F, 8F5*, 8TA 8M, M8A, M8Z		TL - Tee with inline flow TA - Tee with angle flow U - Union	S - Carbon Steel	

* **NOTE:** Male SAE port will be supplied with a fluorocarbon rubber O-ring seal by adding O after F5; i.e., 4F5O.

Oxygen cleaning: Add the suffix **-C3** to the end of the part number to receive valves cleaned for oxygen service per IVD Specification ES8003.

! WARNING

FAILURE, IMPROPER SELECTION OR IMPROPER USE OF THE PRODUCTS AND/OR SYSTEMS DESCRIBED HEREIN OR RELATED ITEMS CAN CAUSE DEATH, PERSONAL INJURY AND PROPERTY DAMAGE.

This document and other information from Parker Hannifin Corporation, its subsidiaries and authorized distributors provide product and/or system options for further investigation by users having technical expertise. It is important that you analyze all aspects of your application and review the information concerning the product or system in the current product catalog. Due to the variety of operating conditions and applications for these products or systems, the user, through its own analysis and testing, is solely responsible for making the final selection of the products and systems and assuring that all performance, safety and warning requirements of the application are met.

The products described herein, including without limitation, product features, specifications, designs, availability and pricing, are subject to change by Parker Hannifin Corporation and its subsidiaries at any time without notice.

Offer of Sale

The items described in this document are hereby offered for sale by Parker Hannifin Corporation, its subsidiaries or its authorized distributors. This offer and its acceptance are governed by the provisions stated in the "Offer of Sale" located in Catalog 4110-U Needle Valves (U Series).

© Copyright 2002, Parker Hannifin Corporation. All Rights Reserved.

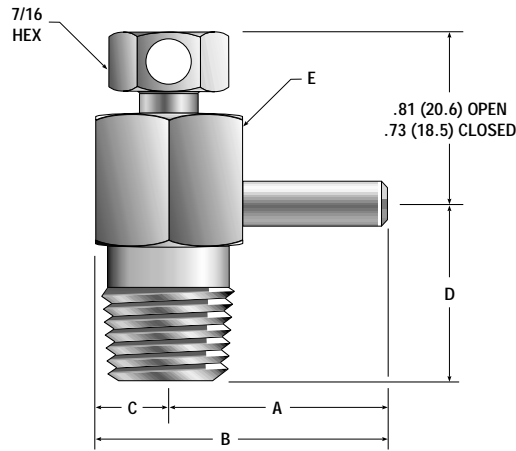

Model Shown: **4M-BV4-SS**

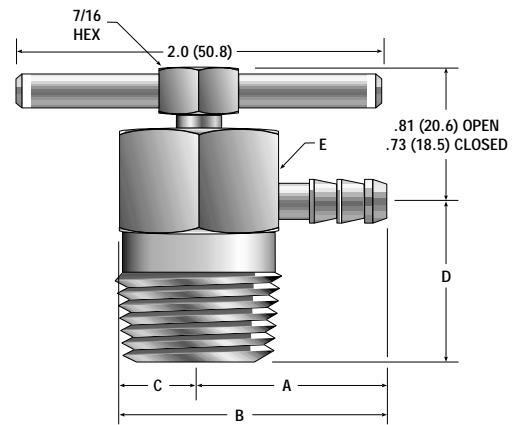

Model Shown: **8M-BV8-SS-BVT-T**

() Denotes dimensions in millimeters

Dimensions

Basic Part Number	Inlet	Outlet	Dimensions									
			A		B		C		D		E (hex)	
			Inch	mm	Inch	mm	Inch	mm	Inch	mm	Inch	mm
2M-BV4	1/8" Male NPT	3/16" O.D. Tube Stub	0.94	23.88	1.24	31.50	0.31	7.87	0.75	19.05	0.63	16.00
4M-BV4	1/4" Male NPT		0.94	23.88	1.24	31.50	0.31	7.87	0.75	19.05	0.63	16.00
4KM-BV4	1/4" Male BSP		0.94	23.88	1.24	31.50	0.31	7.87	0.75	19.05	0.63	16.00
4F5-BV4	1/4" Male SAE		0.94	23.88	1.24	31.50	0.31	7.87	0.69	17.53	0.63	16.00
6M-BV8	3/8" Male NPT	Stub	1.03	26.16	1.49	37.85	0.44	11.18	0.88	22.35	0.88	22.35
8M-BV8	1/2" Male NPT		1.03	26.16	1.49	37.85	0.44	11.18	0.88	22.35	0.88	22.35
8F5-BV8	1/2" Male SAE		1.03	26.16	1.49	37.85	0.44	11.18	0.88	22.35	0.88	22.35

How to Order Bleed Valves

The correct part number is easily derived by following the circled number sequence. The five product characteristics required are coded as shown below.

Example: 4M - BV4 - SS - BVT -
 ① ② ③ ④ ⑤

Describes a stainless steel BV4 Bleed Valve with a 1/4" male NPT inlet and a barbed vent tube outlet.

End Connection ①	Valve Series ②	Material ③	Vent Selection ④	Handle Option ⑤
2M 4KM 4M 4F5*	BV4	SS - Stainless Steel	Blank - Vent Tube	Blank - No Handle
6M 8M 8F5*		M - Alloy N24135	BVT - Barbed Vent Tube	

* Note: Male SAE port will be supplied with a fluorocarbon rubber O-ring by adding O after F5; i.e., 4F5O.

Available Bleed Valve End Connections

M-ANSI/ASME B1.20.1,
External pipe threads

F5-SAE J1926/2 Part 2:
Heavy-duty (S Series)
stud ends

KM-British Standard
BS21 (ISO 7-1),
External pipe threads





Catalog 4133-BP, 20M, 02/02

Parker Hannifin Corporation
Instrumentation Valve Division
2651 Alabama Highway 21 North
Jacksonville, AL 36265-9681
USA
Phone: (256) 435-2130
Fax: (256) 435-7718
www.parker.com/IVD



Parker Hannifin plc
Instrumentation Products Division
Riverside Road
Pottington Business Park
Barnstaple, Devon EX31 1NP
England
Phone: +44 (0) 1271 313131
Fax: +44 (0) 1271 373636
Email: ipd@parker.com
www.parker.com/IPD

